



RWA5100HD

INSTRUCTION MANUAL



OPERATION & MAINTENANCE MANUAL

COMPOSITION

66 pages (including cover pages)

63 numbered pages

- For any further information please contact your local dealer. Contact info are on the last page:

IMPORTANT Any damage caused by failure to follow the instructions in this manual or improper machine use shall relieve the manufacturer of all liability.

SYMBOLS USED IN THE MANUAL







	This symbol instructs the user to refer to this manual before using the equipment or any parts of it.
	This symbol indicates to the user that there are important operations to read about and instructions that demand attention in the documentation that accompanies the product.
	This symbol indicates hazardous operations or conditions. Carefully consult the text shown together with this symbol and follow the instructions to avoid hazards.
 WARNING	This symbol indicates that failure to follow the instructions could result in death or serious injury.
 ATTENTION	This symbol indicates that failure to follow the instructions could cause minor personal injury or damage to the equipment.
	This symbol indicates an operation that requires special attention because there are sharp edges.
	This symbol indicates an operation that requires special attention because chemicals are present. Protect hands. Appropriate protective gloves must be used to protect against corrosive substances.

TABLE OF CONTENTS

0	WARNING	3
0.1	Preliminary safety information	3
1	INTENDED USE	5
2	TRAINING OF DESIGNATED PERSONNEL	5
2.1	General prevention measures	5
3	EQUIPMENT COMPONENTS	7
3.1	RWA5100HD	7
3.2	TABLET	8
3.3	SENSORS	9
3.3.1	<i>Measuring head keypads</i>	10
3.3.2	<i>Automatic shutdown of detectors</i>	10
3.3.3	<i>Low battery warning</i>	10
3.4	WHEEL CLAMPS STDA92E.....	11
3.5	TURNPLATES STDA29L (available in option)	11
4	EQUIPMENT CHARACTERISTICS	11
4.1	Safety devices.....	11
4.2	Measuring ranges and precision	12
4.3	Overall dimensions/weights.....	12
5	TRANSPORTATION AND INSTALLATION	13
5.1	Transportation and unpacking	13
5.2	Installation	13
5.3	Electrical connection	13
6	APPLICATION SETTINGS	14
6.1	Program configuration.....	14
6.2	DATABASE configuration.....	15
7	VEHICLE DIAGNOSIS AND ADJUSTMENT	16
7.1	Home page.....	16
7.2	Vehicle make and model selection	16
7.3	Viewing the technical data of the preselected vehicle	18
7.3.1	<i>Display of ADDITIONAL MEASUREMENTS on RIDE HEIGHTS</i>	19
7.3.2	<i>Display of VERIFICATION MEASUREMENTS on RIDE HEIGHTS</i>	20
7.3.3	<i>Viewing of ADJUSTMENT AID images</i>	21
7.4	Preliminary operations.....	22
7.4.1	<i>Preliminary vehicle check operations</i>	22
7.4.2	<i>Preparation for run-out</i>	22
7.5	Run-out.....	23
7.5.1	<i>Run-out with wheels raised</i>	23
7.5.2	<i>Push run-out</i>	25
7.6	Preparation for measurements	27
7.7	Alignment and levelling / direct measurements	27
7.8	Steering procedure	28
7.9	Vehicle diagnosis.....	29
7.10	Preparation for adjustment	29
7.11	Rear axle adjustment	30
7.12	Front axle adjustment.....	30
7.12.1	<i>Adjustment of front toe with wheels steered</i>	32
7.12.2	<i>"Jack-Hold" procedure</i>	33
7.13	DIAGNOSIS and ADJUSTMENT data summary	34
7.13.1	<i>Chassis diagnosis</i>	34
7.13.2	<i>"Test Drive" procedure</i>	35
7.14	Auxiliary functions menu	36
7.15	Measurements print-out.....	37

7.16	Saving tests carried out with TEq-Link.....	42
7.16.1	<i>TEq-Link function configuration</i>	42
8	DIAGNOSIS AND ADJUSTMENT OF TRUCKS	43
8.1	Adjustment of 3-axle tractor - 1 steering axle.....	43
8.2	Adjustment of a 3-axle semi-trailer	48
8.3	Adjustment of 3-axle tractor - 2 steering axles.....	51
8.4	Adjustment of a full-trailer with drawbar.....	56
9	ERROR NOTIFICATIONS	60
10	PROBLEMS	61
11	MAINTENANCE	61
12	STORAGE AND SCRAPPING	62
13	MACHINE IDENTIFICATION DATA/WARNING LABELS	63

0 WARNING

Any damage deriving from failure to observe the instructions contained in this manual and from improper use of the machine releases the manufacturer from any liability.



IMPORTANT SAFETY INSTRUCTIONS, READ AND SAVE THESE INSTRUCTIONS

When using your garage equipment, basic safety precautions should always be followed, including the following:

- Read all instructions.
- Care must be taken as burns can occur from touching hot parts.
- Do not operate equipment with a damaged cord or if the equipment has been dropped or damaged – until it has been examined by a qualified service person.
- Do not let a cord hang over the edge of the table, bench, or counter or come in contact with hot manifolds or moving fan blades.
- If an extension cord is necessary, a cord with a current rating equal to or more than that of the equipment should be used. Cords rated for less current than the equipment may overheat. Care should be taken to arrange the cord so that it will not be tripped over or pulled.
- Always unplug equipment from electrical outlet when not in use. Never use the cord to pull the plug from the outlet. Grasp plug and pull to disconnect.
- Let equipment cool completely before putting away. Loop cord loosely around equipment when storing.
- To reduce the risk of fire, do not operate equipment in the vicinity of open containers of flammable liquids (gasoline).
- Adequate ventilation should be provided when working on operating internal combustion engines.
- Keep hair, loose clothing, fingers, and all parts of body away from moving parts.
- To reduce the risk of electric shock, do not use on wet surfaces or expose to rain.
- Use only as described in this manual. Use only manufacturer's recommended attachments.
- ALWAYS WEAR SAFETY GLASSES. Everyday eyeglasses only have impact resistant lenses, they are not safety glasses.
- To reduce the risk of injury, close supervision is necessary when this product will be used around children. (Pertains to cabinets only.)

0.1 Preliminary safety information



Before turning on the equipment:

- Read the instructions and the entire manual before using or working on the wheel aligner. This manual is an integral part of the product and is intended to provide the user with instructions on the use of the RWA5100HD wheel aligner. Therefore, keep it, for the entire operating life of the machine, in a known and easily accessible place and consult it whenever uncertainties arise. All product operators must be able to read the manual.
- Check that the power supply complies with the specifications shown on the plate. The plate with the voltage and frequency data is located on the back of the equipment. Please note the information on the plate. NEVER connect the appliance to a voltage or frequency other than those indicated.
- Properly arrange the power cable of the wheel aligner. This product has a built-in 3-wire earthing plug. It only fits into a socket that is also earthed. If it is not possible to insert the plug into a socket of this type, please consult an electrician. Do not modify or misuse the plug



In emergency conditions and before any maintenance work:

- Isolate the machine from the energy sources, with the appropriate main switch of the machine and remove the plug from the power socket.
- Do not try to perform maintenance this unit arbitrarily, as removing the panels could expose you to dangerous voltages; maintenance to this machine must only be carried out and exclusively by authorized service personnel.



Work environment and cleaning of equipment:

- Work environment must be kept clean, dry, not exposed to outside elements and sufficiently lit. Do not locate the equipment in places where there are oils or corrosive substances.
- Avoid cleaning the equipment with jets of water and compressed air.
To clean plastic panels or shelves, use a damp cloth (avoid liquids containing solvents).



Rotary may at any time make changes to the vehicles described in this manual for technical or commercial reasons.



*The trademark **TEQLink** is owned by Rotary. All the remaining trademarks mentioned, the reproduced logos and the images belong to the legitimate owners who fully hold the relevant rights.*

1 INTENDED USE

The RWA5100HD system is equipment intended for total detection of the characteristic angles of light vehicles and trucks.

The angle detection is carried out by four sensors with microprocessor technology and infrared measuring and data transmission system (without using cable connections between the sensors).

Data transmission from the measuring heads takes place VIA RADIO via Bluetooth-compatible modules.

Use the equipment (CAT II) in the following operating range:

- Internal use
- Temperature from 32°F (0°C) to 104°F (40°C)
- Relative humidity from 30% to 70%
- Maximum altitude 9842Ft (3000M) above sea level (asl)

2 TRAINING OF DESIGNATED PERSONNEL

Only specially trained and authorized personnel may use the equipment. In order to ensure machine management are optimal and for measurements to be carried out efficiently, the designated personnel must be properly trained to learn the necessary information in order to achieve an operating mode that is in line with the instructions provided by the manufacturer. For any uncertainty relating to the use and maintenance of the machine, consult the instruction manual; if unsure, do not interpret but instead consult the authorized service centres or the technical assistance directly.

2.1 General prevention measures



ATTENTION

- During the operation and maintenance of this machine it is absolutely essential to comply with all the safety and accident-prevention regulations in force and with the European Directives 89/686/ EEC, UNI EN ISO 20345, UNI EN ISO 13688: 2013, EN 388 and EN 420.
- The equipment must only be used by authorized and adequately trained personnel.
- It is not permitted to attach very heavy objects (weighing more than 33lb (15kg) on the console (e.g.: rotary plates).
- Do not use the equipment in places where a lot of dust is present (pollution degree equal to or greater than 3).
- Do not install or store the device in outdoor areas or in areas exposed to climatic conditions such as direct sunlight, wind, rain or temperatures below freezing.
- When operating the device outside the specified conditions, there is a risk that its safety and operation could be compromised.
- Always insure that the equipment is positioned in such a way that the electrical outlet is accessible.
- The equipment must always be on a flat and horizontal surface.
- If the power cord is damaged, it must be replaced by the manufacturer, an authorized dealer or qualified personnel to avoid danger.
- It is important to keep this manual for future use. It is an integral part of the equipment. For this reason, it should always be with the equipment.

 **WARNING**

- For safety reasons, plug the cord into a grounded AC outlet.
- **Risk of Fire and explosion!** To mitigate this risk the machine must only operate in places where there is no danger of explosion or fire. This product shall only be installed and used within the ordinary location of a minor repair garage as defined by the National Electrical Code.
- **Risk of electric shock!** Never open the system. For continued protection against electric shock the cabinet must be connected to a reliable ground connection. Do not remove the ground connection. If the receptacle in the building installation does not contain a ground pin connection, do not modify the attachment plug.
- This equipment must only be used for the purpose for which it is expressly designed. ROTARY declines all responsibility for damage to persons, animals and property caused by improper use of the machine.
- The installation of accessories and spare parts must be performed by authorized ROTARY personnel and original accessories and spare parts must be used. It is also not permitted, in any way, to replace batteries using non-original batteries. It is necessary to use only the manufacturer's original batteries on the measuring heads.
- The removal or modification of safety devices or of warning signs placed on the machine can cause serious danger and constitutes a violation of the OSHA safety standards.
- Before carrying out any maintenance on the system, it is necessary to disconnect the power supply. If in doubt, do not guess, contact the ROTARY technical assistance in advance in order to receive information to be able to perform operations in conditions of maximum safety.
- The operator must wear safety footwear to avoid damage to their feet, caused by the accidental falling of clamps or measuring heads. Use footwear with certified protection according to the EN ISO 20345 standard.
- The operator must wear protective gloves when handling the clamps. Use gloves according to the EN 388 standard.
- Prevent unauthorized personnel from approaching the wheel aligner during use.
- Use only the supplied cables. In the event of breakage or a fault, consult qualified service personnel.
- Never try to use the equipment if it is damaged, if it works incorrectly, if it has been partially disassembled and if any components, including cable and plug, are missing or damaged.

3 EQUIPMENT COMPONENTS

3.1 RWA5100HD

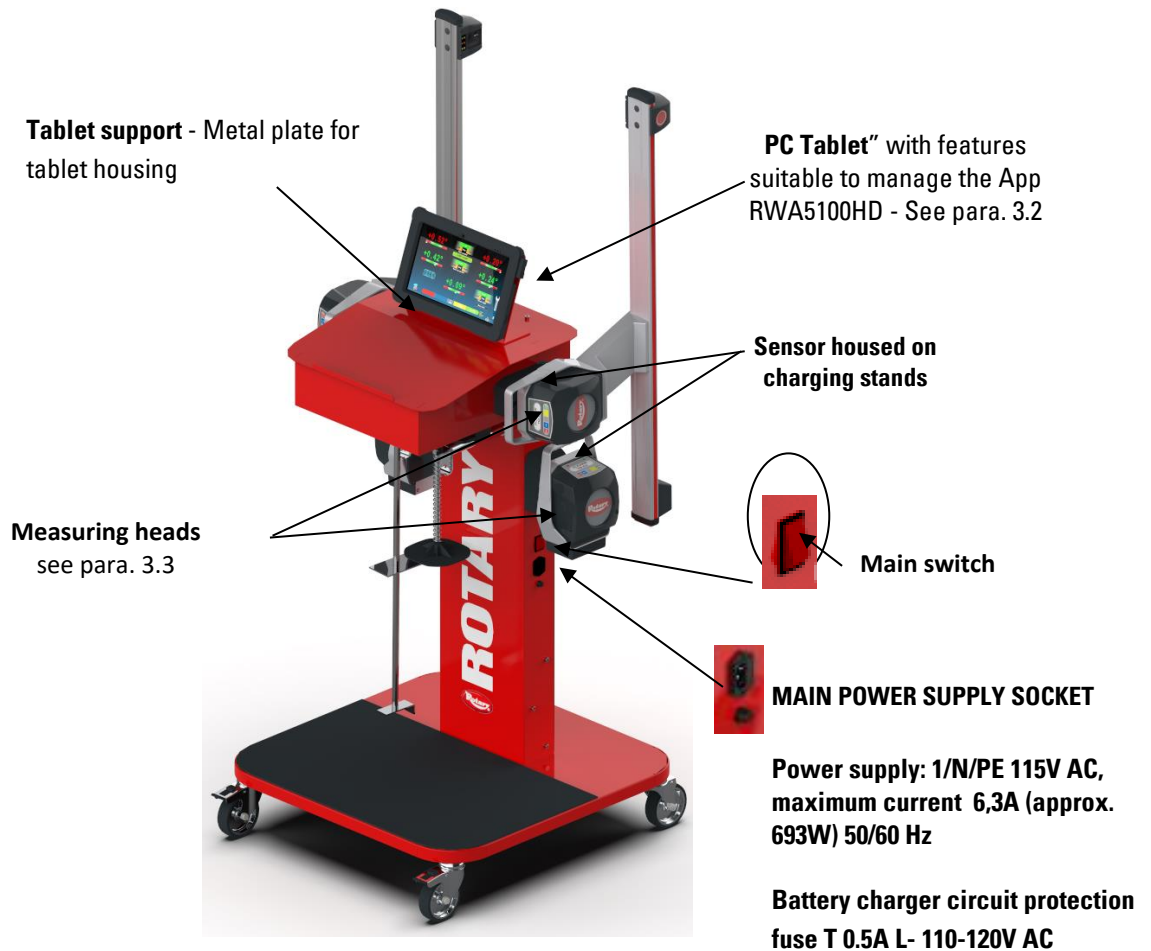

Figure 1

ATTENTION

The equipment is equipped with two protection fuses, one on the neutral. The fuses are inside the side-mounted power socket.

Use only **T 6,3A L - 115V AC**.

THE PUSH PEDAL is a tool used to lock the brake pedal during the preparation operations for measurements. It is to be used as shown in the instructions that appear during the program.

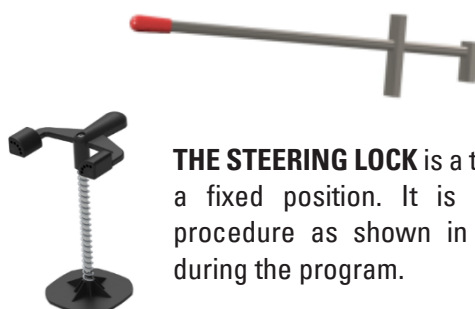

3.2 TABLET

The equipment includes a "Rugged" tablet PC. The Device is supplied with adequate requirements (see minimum characteristics below) to manage the APP RWA5100HD

The table shows the minimum characteristics for operation of the APP

- Processor 2,4Ghz;
- RAM 8 Gb;
- 1 USB 3.0 Type C, 1 USB 3.0 Type A
- Bluetooth 4.0
- WiFi 802.11ac/b/g/n
- Operating system Windows 10 in English
- Hard Disk ≥ 180 Gb

The device is equipped with three magnets fixed on the back, to be able to secure it on the vehicle lift or on the vehicle chassis, for example during adjustment operations.



Figure 2

At the first launch of the application you will need to enter the codes for the activation of the license, which are shown in a document supplied with it. Subsequently, it will be necessary to enter some data relating to the user, to start the start of the manufacturer's warranty. Keep the document with the codes because if the application is uninstalled and reinstalled these are requested again.

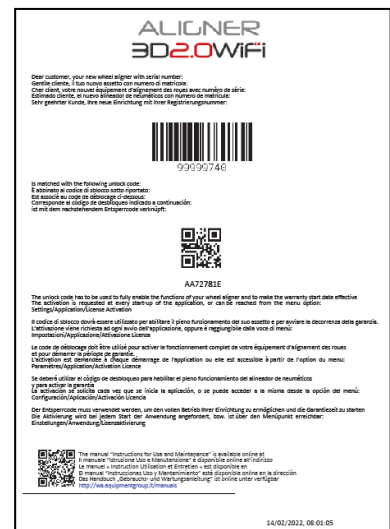

Figure 3

3.3 SENSORS

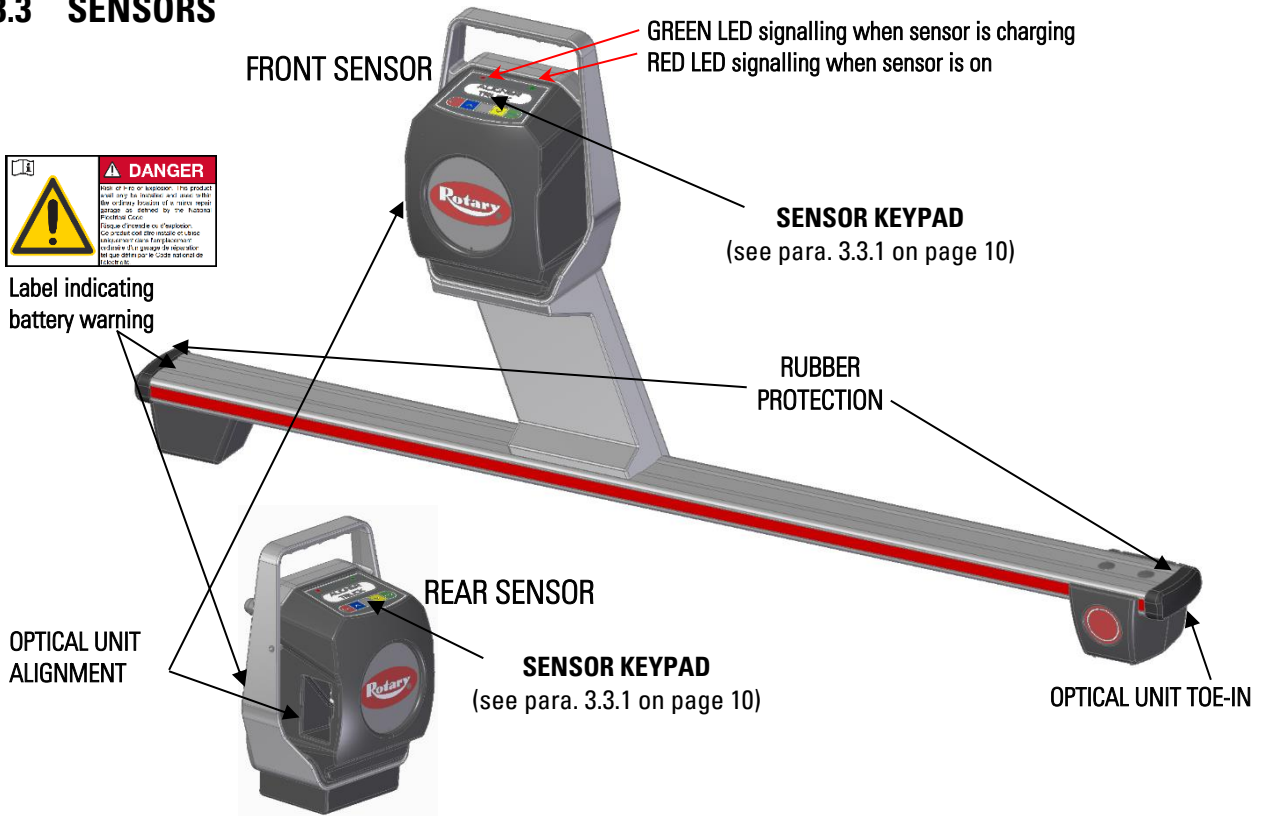

Figure 4

The sensors of the RWA5100HD equipment do not need the connection of any cable or lanyard for angle measurement.

The sensors units consist of infrared data transmitters/receivers and CCD-type transducers with infrared emitter focal point. All the characteristic angles of both vehicle axles are controlled by 8 CCD sensors with infrared measurement.

The front sensors communicate with the control device (Tablet), using compatible bluetooth modules. The data from the rear sensors are transmitted/received by passing through the front sensors, using the infrared transmission. Data transmission between infrared detectors is effective even in critical lighting conditions.

The power supply is provided by 6V long-life rechargeable batteries. The batteries of the front and rear sensors; are recharged by means of the special charging stands

ATTENTION

- The rechargeable batteries are contained in a plastic housing. If there are any signs of corrosion, swelling of the container or damage to the container, the battery must be removed immediately and replaced with a new, undamaged, original one.
- The batteries must be handled with care. The user must wear protective gloves.
- Do not open or tamper with the battery pack and its shell.
- Use only the supplied battery pack

WARNING

- Do not cause short circuits and do not disassemble the battery pack.
- Do not expose the battery pack to excessive heat sources.

The power and consumption data of the measuring heads with rechargeable battery are as follows:

Power supply	NiMH battery (Nickel-Metal Hydride) 6V- 2Ah
Average operation with battery in full efficiency and charged	Approximately 8 hours
Average charging time	Approximately 12 hours

3.3.1 Measuring head keypads



Figure 5

KEYS	DESCRIPTION
	Sensor power key.
	Pressed at the same time, they manually switch off the sensor.

Legend of Figure 5:

- | | | |
|-----|--|---|
| A - | <ul style="list-style-type: none"> • Green Led : | <ul style="list-style-type: none"> the sensor battery is charging |
| B - | <ul style="list-style-type: none"> • Red Led on steady: • Red Led flashing : | <ul style="list-style-type: none"> The sensor is on The sensor battery is low (when the remaining battery charge is lower than or equal to 30%); it will turn off after a few minutes |

3.3.2 Automatic shutdown of detectors

The detectors turn off automatically after approximately 5 min. if they do not receive data, that is when the program is in a phase where data for the measurement are not transmitted/received (e.g. on the home page) or if the tablet is switched off. In any case, the detectors can always be switched off manually (see the table in para. 3.3.1) when they are not being used

3.3.3 Low battery warning

When the residual charge of one or more detectors is LOWER than or EQUAL to 30%, the program displays an error condition (see chapt. 9 on page 60) with the details of the charge percentage (Figure 6). This signal is also given on the detector itself with flashing of the red power LED (see para. 3.3.1 on page 10).

It is necessary to place the detector back on charge as soon as possible

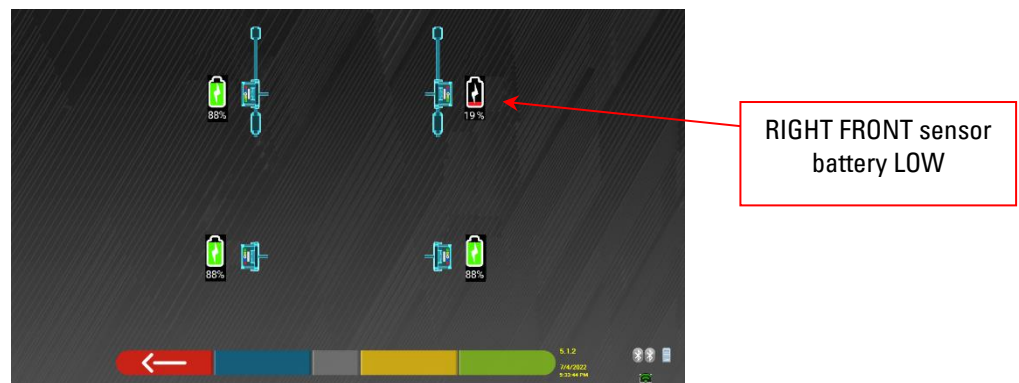

Figure 6

To quit the warning page press key .

3.4 WHEEL CLAMPS STDA92E

Special NON Run-out compensation wheel clamps, by referencing the wheel center which is almost perfectly accurate, it can deliver a more accurate measurement without need to raise each wheel position to perform Run-out compensation

Each pair of clamps includes: 6 short adapters and 6 long adapters

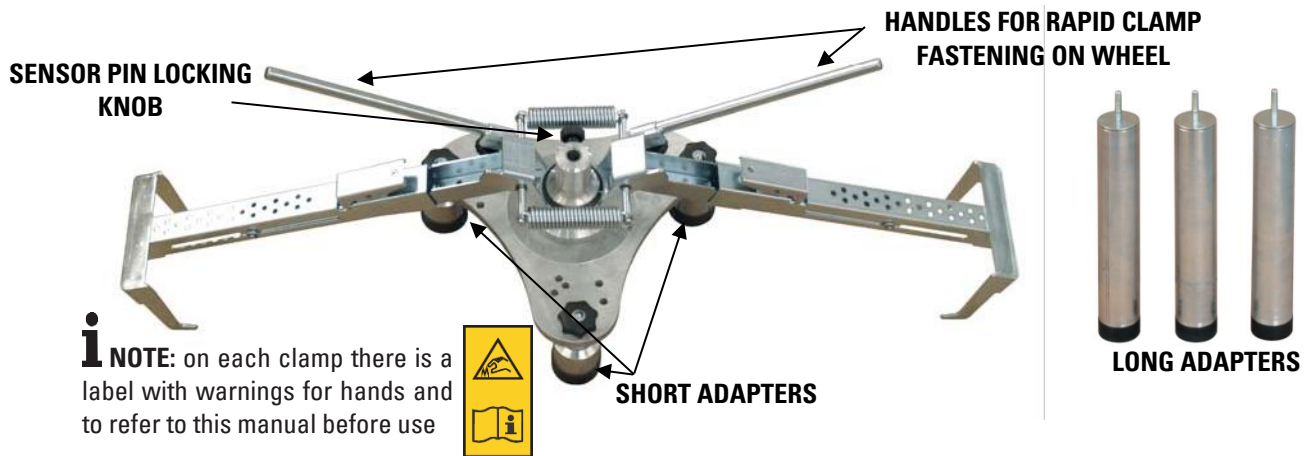

Figure 7

3.5 TURNPLATES STDA29L (available in option)

The turnplates STDA29L have a capacity of 7000 kg.



Figure 8

1. Plate handle
2. Plate stop
3. Upper plate with anti-drip disc

4 EQUIPMENT CHARACTERISTICS

4.1 Safety devices

The wheel aligner is equipped with a safety device (main switch) located laterally on the central panel of the machine, see Figure 1 on page 7. The main switch deactivates the power supply of the machine when placed in the "0" position.

WARNING

- In case of emergency or danger, unplug the power cord.

4.2 Measuring ranges and precision

Axle	Measurement	Precision	Measuring range	Total Measuring range
Front	Toe	± 2'	± 2°	± 20° x 2
	Partial toe	± 1'	± 1°	± 20°
	Set-back	± 2	± 2°	± 5°
	Camber	± 2'	± 3°	± 10°
	Caster	± 5'	± 10°	± 18°
	King-pin	± 5'	± 10°	± 18°
Rear	Toe	± 2'	± 2°	± 20° x 2
	Partial toe	± 1'	± 1°	± 20°
	Set-back	± 2'	± 2°	± 5°
	Camber	± 2'	± 3°	± 10°
	Thrust angle	± 2'	± 2°	± 5°

4.3 Overall dimensions/weights

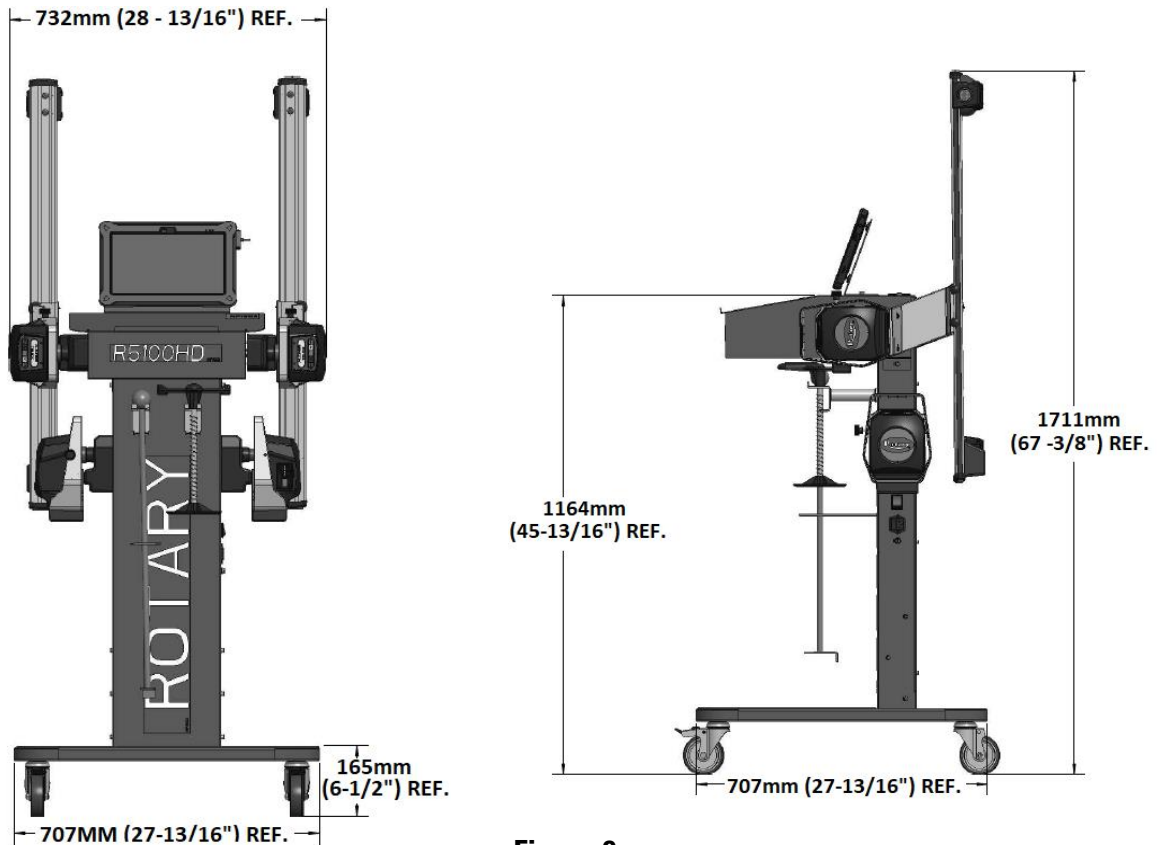

Figure 9

Weights

- Only cabinet: 88lb (40kg)
- Complete with measuring heads + tablet: 117lb (53 kg)
- Complete with couple of turntables STDA29L: 214lb (97 kg)



ATTENTION

turntables STDA29L accessories must be placed on the lower base.



5 TRANSPORTATION AND INSTALLATION

5.1 Transportation and unpacking

The equipment is supplied packed in a box secured onto a pallet to facilitate transportation.



ATTENTION

- To transport the machine to the point where it will be installed, use lifting and transport means such as forklifts or lifters equipped with forks.
- The equipment must be stored and packaged in areas protected from the element's, not exposed to rain or temperatures below freezing and preferably dry and well ventilated.
- The packaging must never be overturned or arranged horizontally, the pallet must always rest on a flat and solid surface, do not stack other packages on top, the arrangement must allow easy reading of the indications.



WARNING

- Always wear gloves and safety shoes during unpacking.

Make sure all parts listed in Figure 1, page 7, are present and undamaged.

The packaging material (plastic bags, polystyrene, nails, screws, wood, etc.) must be kept collected and disposed of according to the regulations in force, with the exception of the pallet, which could be reused for subsequent handling of the machine.

5.2 Installation



ATTENTION

- Do not install the equipment in places where an over abundance of dust is present (pollution degree equal to or greater than 3).

Install the equipment in indoor areas, sufficiently lit and protected from outside elements. The minimum dimensions of the area where the cabinet can be located are 2500x2500 mm (98-7/16" x98-7/16"), the dimensions of the cabinet are indicated in chapter 4.3



WARNING

- Before positioning the equipment, make sure that the chosen location is suitable for the local regulations in force on workplace safety and check the minimum distances from walls or other obstacles.
- The enclosure's electrical socket must be free from obstacles and accessible in an emergency

5.3 Electrical connection



ATTENTION

Before connecting the machine, carefully check that:

- the characteristics of the power line correspond to the requirements of the machine indicated on the relative plate;
- the earthing line is present and that it is adequately sized (section greater than or equal to the maximum section of the power cables);
- all the components of the power line are in a good condition;



WARNING

- Connect the machine to the mains using the supplied 3-pin plug (115 AC) via the wall socket. If the plug supplied is not suitable for the one on the wall, equip the machine with the plug in accordance with the local laws and current standards and regulations. This operation must be performed by experienced and qualified personnel.
- Risk of Fire and explosion! To mitigate this risk the machine must only operate in places where there is no danger of explosion or fire. This product shall only be installed and used within the ordinary location of a minor repair garage as defined by the National Electrical Code.

6 APPLICATION SETTINGS

6.1 Program configuration

To start the RWA5100HD program click on the icon ; the program starts and the presentation page is displayed on the PC Tablet, from where it is possible to access all the main functions of the equipment.

i *the functions actually available may depend on the type of device and version of the operating system in use.*



Figure 10

To configure the program, select the F2 key  on the introductory page. A configuration menu is accessed that can be used to change the characteristics of the program according to requirements.

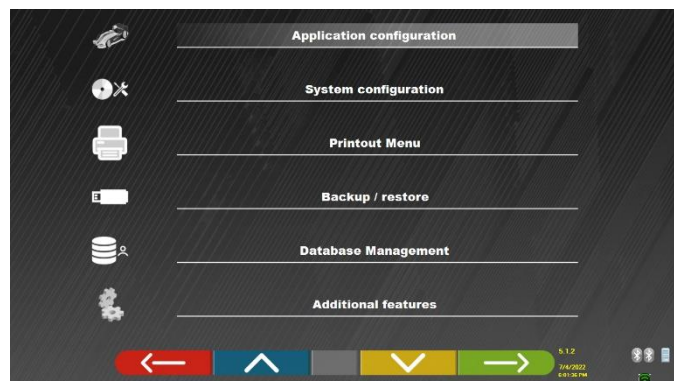

Figure 11

Application Configuration: It is possible to select a language from those available; it is possible to set the rules for the data protection policy

System configuration: The system parameters can be modified: customize the vehicle database, selecting which “groups” to show, or create new groups or edit existing ones by adding or removing makes; specify which components are included in the equipment and their type, make a Bluetooth search to pair the sensor heads with the Tablet.

Prints Menu: It is possible to personalise the print-out by entering the workshop data, to choose the type of print-out required and to select the default printer (if there are more than one connected).

Backup / Restore: In order not to risk losing the vehicle and customer database data, it is advisable to create a backup copy (save). A “flash disk” USB key is used for this operation. It is possible to recover lost or deleted data, if the backup operation was performed, with the restore procedure.

Database Management, see para. 6.2

Additional features: it is possible to access the TEST or Calibration applications of the sensors (reserved to specialised and authorized personnel)

6.2 DATABASE configuration

It is possible to view information on existing databases or check for new updates. Select the option "DATABASE MANAGEMENT" on the program configuration page - See para. 6.1, the page shown below will appear.

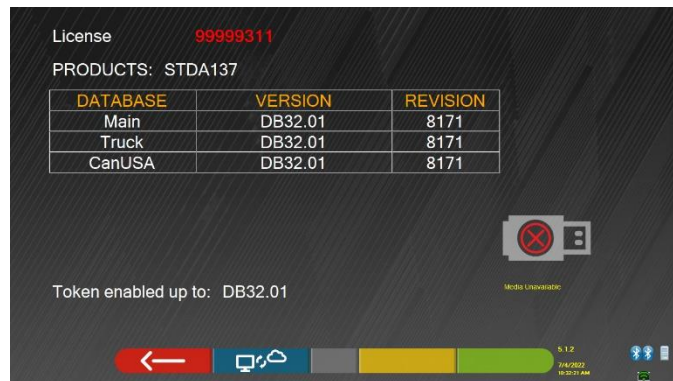



Figure 12

The page illustrated above shows the databases present and relative version. The licence number is shown, corresponding to the serial number of the equipment, which needs to be communicated to the manufacturer to purchase a new database.

Press the F2 key  to check for the presence of new program updates or the availability of new database releases.

7 VEHICLE DIAGNOSIS AND ADJUSTMENT

With the RWA5100HD wheel aligner, it is also possible to take vehicle measurements, however specific clamps are needed for cars.

i possible only with very large wheels (diam. > 760mm)..

7.1 Home page

When the equipment is turned on, the home page appears with a selection of possible functions.

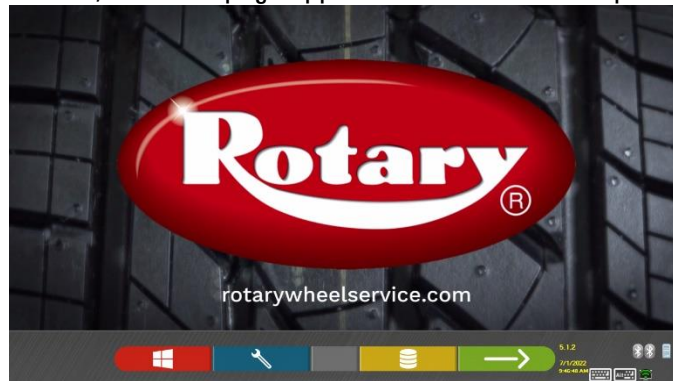





Figure 13

	DESCRIPTION
	Closes the application
	Program configuration (para. 6.1)
	Opens the customer database
	Selects the list with the various database profiles

Press the F4 key  to continue.

7.2 Vehicle make and model selection



List with the different database profiles

Figure 14

Press the F4 key  to select a vehicle make and model. The program shows the list of makes in the preselected group (see Figure 16).

Alternatively, press the F5 key  to run a search using keys (model/make/year) or using the V.I.N. (Vehicle Identification Number – for motor vehicles only), which is a unique serial number used by the automotive

industry to identify motor vehicles. The VIN plate with 17 alphanumeric characters is normally located inside the engine compartment.

Note: use the F5 key to select the search mode: with search keys Name/ make/model/year, or VIN or with a manual selection (Figure 16).

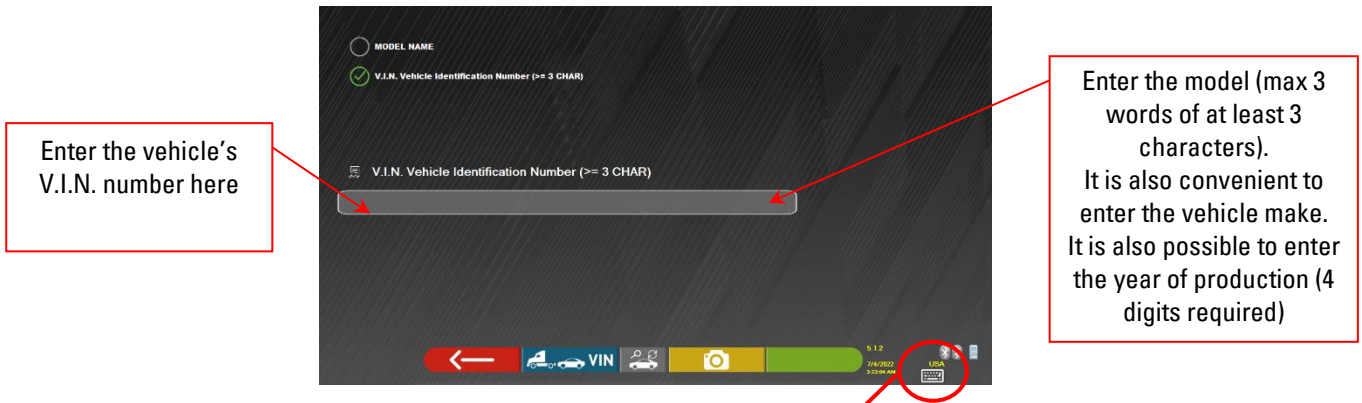
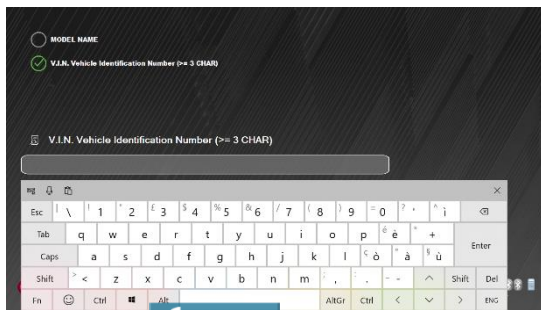





Figure 15



i the virtual keyboard to insert text or special characters automatically appears when a field is selected requiring the insertion of text. The virtual keyboard can also be called up by “double clicking” on the keyboard symbol on the bottom right of the screen

Press the F2 key  to move the cursor from the “vehicle name” field to the “V.I.N.” field.

Press the F4 key  to continue and view the list of all vehicles that satisfy the search criteria entered above, then select the correct vehicle and view the page with the technical data of the preselected vehicle

To be able to select the make and model of a vehicle, press the F4 key  on the home page (Figure 13) or on the page with the database profiles (Figure 14)

The program displays the following page:

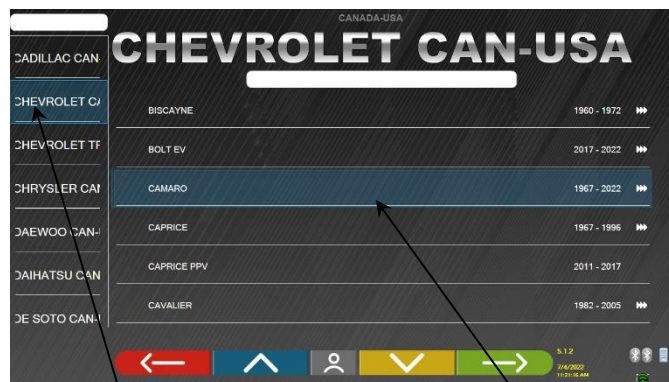

Vehicle make selected

Vehicle model selected

Figure 16

It is necessary to select the make and model of the vehicle on which to operate.

7.3 Viewing the technical data of the preselected vehicle

After selecting the vehicle (see para. 7.2), a screen appears with the measurements and tolerances of the angles (minimum, central, and maximum value) and other additional data, such as the rim diameter, wheelbase, track and any load and tank conditions (Figure 17).

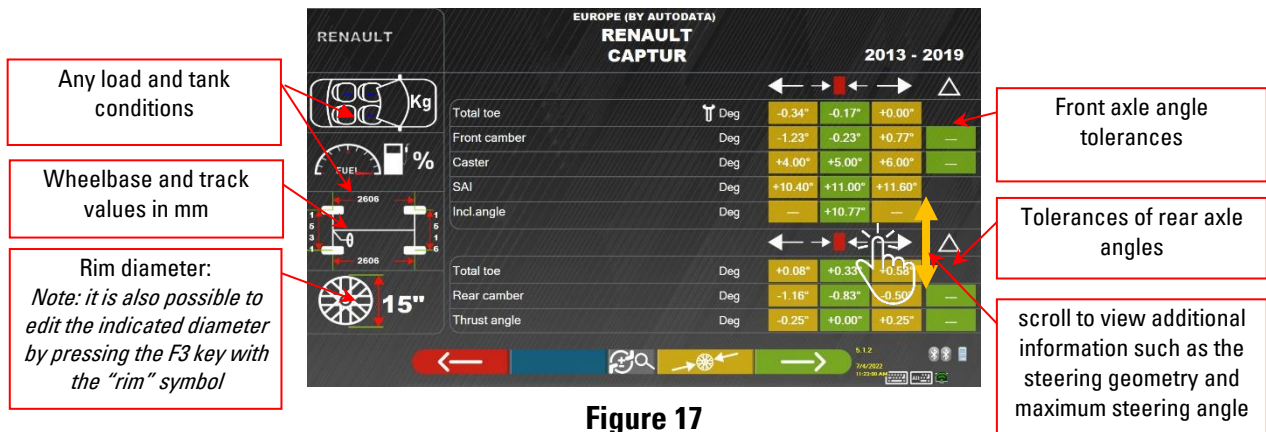



Figure 17

The screen with the measurements and tolerances can be viewed as in Figure 17: with a single column of consistent values for the left side and right side. By pressing the F5 key  it is possible to view the measurements with the central value and overall tolerance "±" (see Figure 18).

In the "System configuration" menu (see para. 6.1) it is also possible to set separate left and right data displays (some vehicles can have slightly different tolerance values for the left and right side).

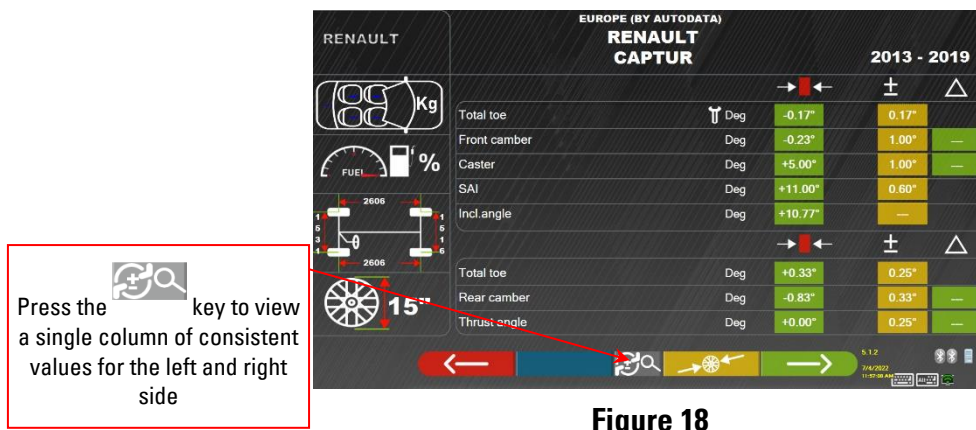



Figure 18

Press the  key to continue with the preliminary operations on the vehicle (para. 7.4 on page 22).

i The PC Tablet device with SW RWA5100HD contains technical information relative to vehicles, provided via the official databases. Access to the system and information is subject to the reading and acceptance of a Disclaimer, which is shown on the device the first time the SW is used.

7.3.1 Display of ADDITIONAL MEASUREMENTS on RIDE HEIGHTS

Some manufacturers (e.g. Mercedes, Renault) provide angle tolerance values according to particular measurements on the vehicle chassis. When the selected vehicle has angle tolerance values connected to additional measurements on the chassis, the technical data page (Figure 19) will feature the  key. Press this key to view the page with details of the measurements on the chassis.

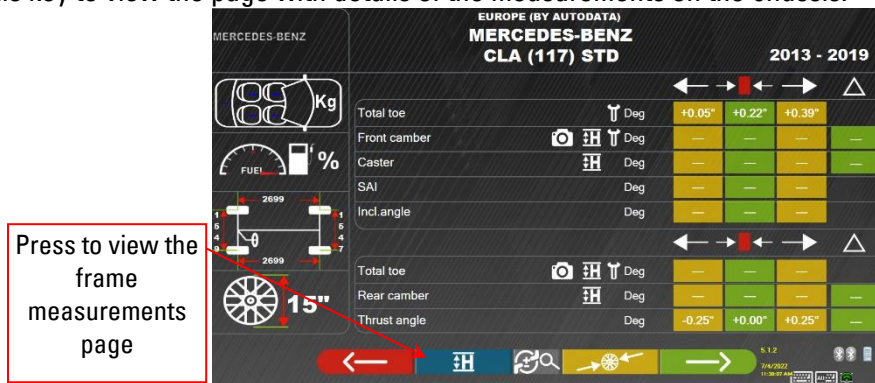



Figure 19

The program shows a page as per the example in Figure 20, click on the symbols  /  to view the different images.

Using the keys  /  scroll the different heights/angles in the tables and select the correct values.

Press  to switch from one table to the other and confirm.

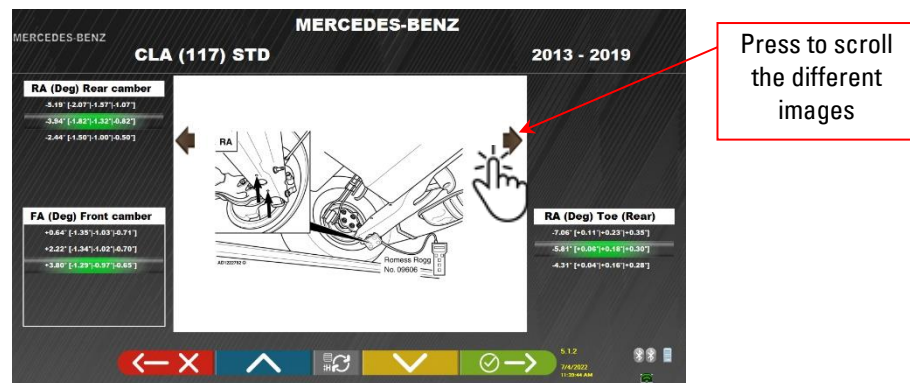



Figure 20

The measurements can be entered by selecting them from the tables, as per the example in Figure 20, or, if the F5 key  is pressed, the page opens as per the example in Figure 21, where the values are entered directly.

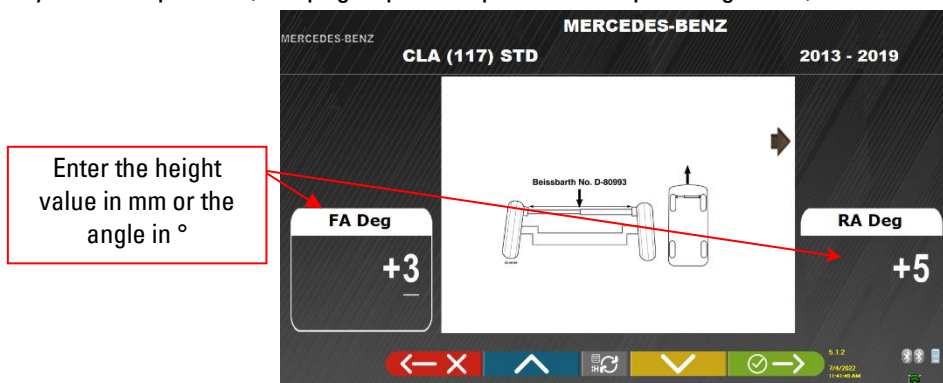



Figure 21

Tap on the F4 key  to confirm the values entered

7.3.2 Display of VERIFICATION MEASUREMENTS on RIDE HEIGHTS

Some manufacturers (e.g. Citroen, Peugeot) provide tolerance values referring to particular measurements on the vehicle chassis (control values).

When the selected vehicle has tolerance values with control values, the  key is included on the technical data page (Figure 22). Press this key to view the page with details of the control values.

Page to view the page with the control values on the chassis

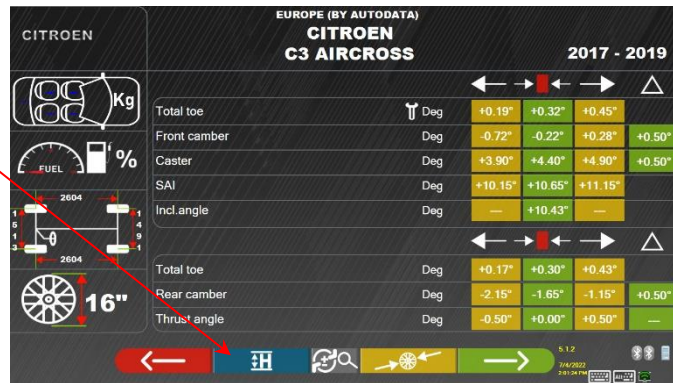

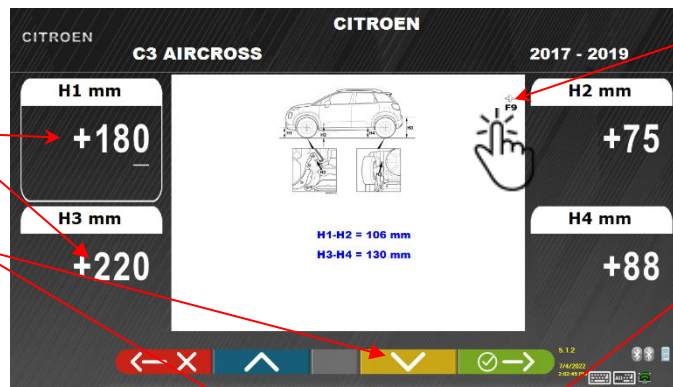

Figure 22

The program shows a page as per the example in Figure 23, select the F9 key or press the  symbol to enlarge the image.

Insert the control values

Using the keys  /  scroll the options of the different fields to complete



Press to enlarge the image

Press  to confirm the values entered

Figure 23

Enter the control values directly, and press the  key to confirm the values entered

7.3.3 Viewing of ADJUSTMENT AID images

For various vehicles of certain manufacturers, images are available to assist with adjustment, which indicate the adjustment modes on the various angles of the vehicle, such as the camber and caster of the front axle or the camber and toe of the rear axle.

When the selected vehicle has adjustment aid images, the technical data page (Figure 24) includes the symbol next to the adjustable angle. Tap the  symbol to view the adjustment aid images.

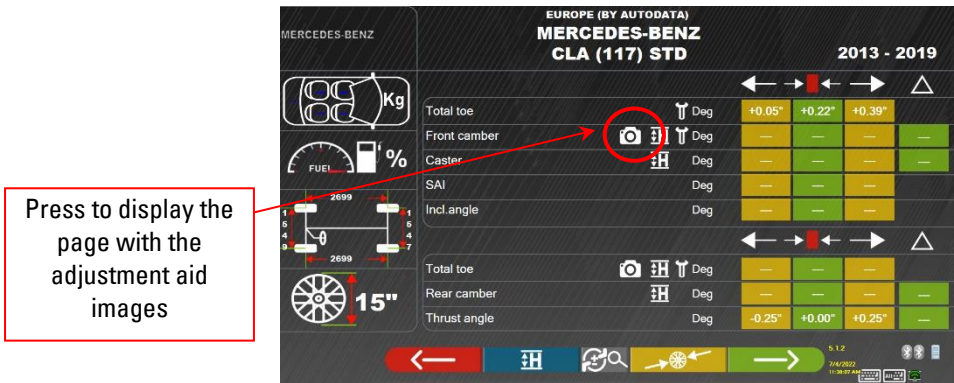



Figure 24

The program shows a page as per the example in Figure 25, use the F2 key  to select the different images if there are 2 or more for the different angles.

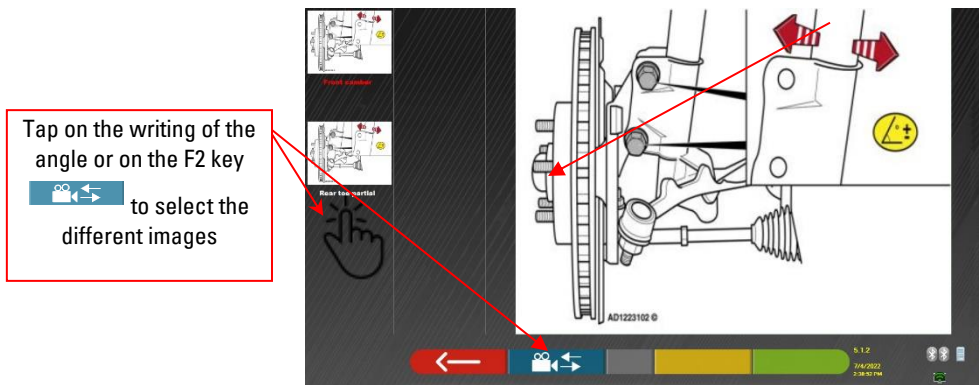



Figure 25

Press the key  to return to the vehicle technical data page.

Note: also during the rear adjustment step (para. 7.11 page 30), if there are adjustment aid images, the  key is available in order to view them.

7.4 Preliminary operations

7.4.1 Preliminary vehicle check operations

Before carrying out the vehicle alignment check, it is necessary to perform a number of preliminary checks:

- Check and if necessary eliminate the play on the suspension and on the steering linkage.
- Check and if necessary eliminate possible hardening or yielding of the elastic parts of the suspensions.
- Adjust the tyre pressure to the values prescribed by the manufacturer.
- Position and distribute any loads envisaged by the manufacturer.

7.4.2 Preparation for run-out

After viewing the vehicle technical data page (see para. 7.3 on page 18) tap on the  key to continue, the page shown in Figure 26 appears, which illustrates the preparation of the vehicle for the run-out procedure:

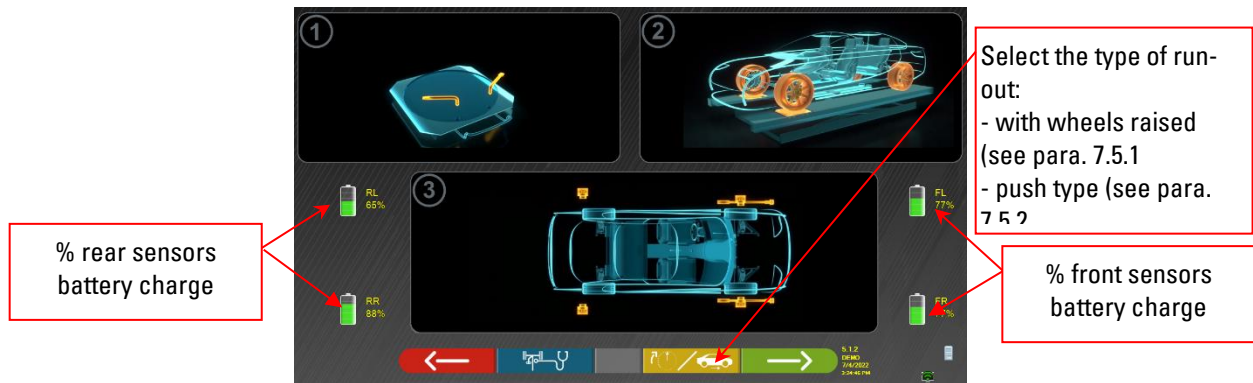



Figure 26

Using the F3 key  it is possible to select the type of run-out: with raised wheels (see para. 7.5.1) or push type (see para. 7.5.2)

Note: during this step, images representing the 4 sensor batteries are shown, with the relative % of residual charge.

- Prepare for the measurements by blocking the radius gauges and all rear steers plates.
- Drive the vehicle in position on the vehicle lift correctly, with the front wheels on the radius gauges.
- Mount the clamps and sensor heads on the wheels



7.5 Run-out

The **run-out** procedure is carried out to compensate for any decentring that exists between the plane passing through the wheel and the one that is actually measured.

However, this procedure can be skipped, when required, with the  key .

This procedure can also be performed after completing the vehicle diagnosis, selecting the relative option in the menu (see para. 7.14 - Preliminary operations).

In order to carry out the run-out procedure, it is necessary to have performed the preparation as explained in para. 7.4.2).

7.5.1 Run-out with wheels raised

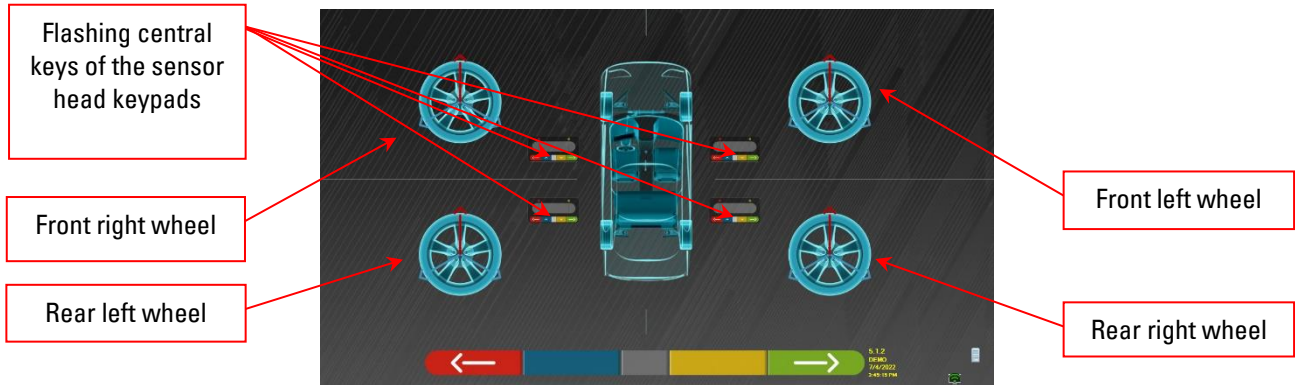

Figure 27

It is advisable to carefully follow the visual instructions that appear on the screen.

During the initial stage, the central keys of the keypads shown on the screen flash to indicate which key to press to start the procedure. It is not necessary to start with a specific wheel or proceed in a specific order (see Figure 27).

The procedure should be carried out on all four wheels. On the screen, the images of the central keys of the sensor head keypads flash, suggesting that the procedure be started by pressing the specific key (see Figure 27).

When the central key of the keypad is pressed, the following screen appears:

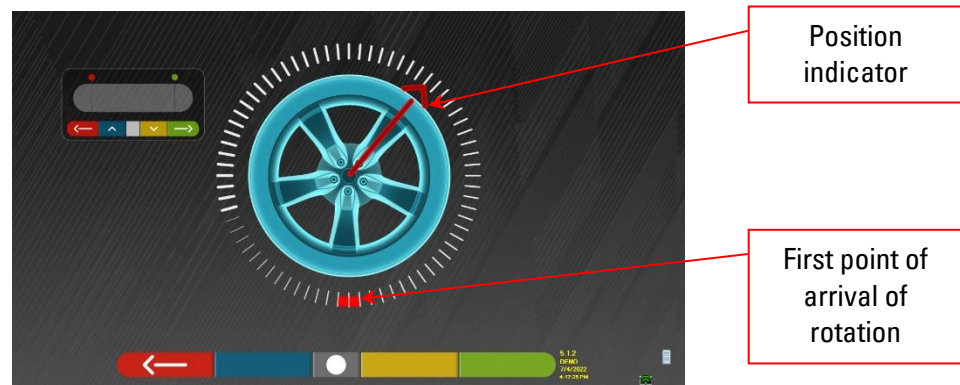

Figure 28

Figure 28 illustrates the current position of the wheel.

At the start of the procedure, a "self-calibration" is run so that the position indicator is positioned up high. As the wheel is manually turned, the wheel position will be updated in real time on the screen, as well as the relative position indicator. The first objective is to turn the wheel by approximately 180°, reaching the first highlighted point. The rotation can be carried out in both directions.

Turn the wheel by 180° and once arrived at destination, press the central key of the sensor head keypad as indicated on the screen in Figure 28.



Figure 29

Figure 29 is displayed for about three seconds, the time necessary for the program to acquire the measurements

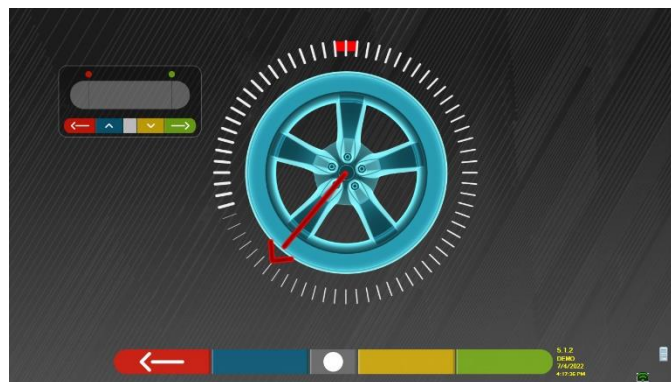

Figure 30

It is now necessary to turn the wheel until the position indicator is aligned with the second point, positioned at 180° from the first position, and therefore coinciding with the starting point.

Turn the wheel by another 180° and once arrived at destination, press the central key of the sensor head keypad as indicated on the screen in Figure 30.

Once the last rotation has been made, the program acquires the last measurements. The screen with the "STOP" symbol in Figure 29 appears again for about three seconds. After having acquired the measurements, the program automatically continues and displays the following screen:

Wheel where the procedure was carried out

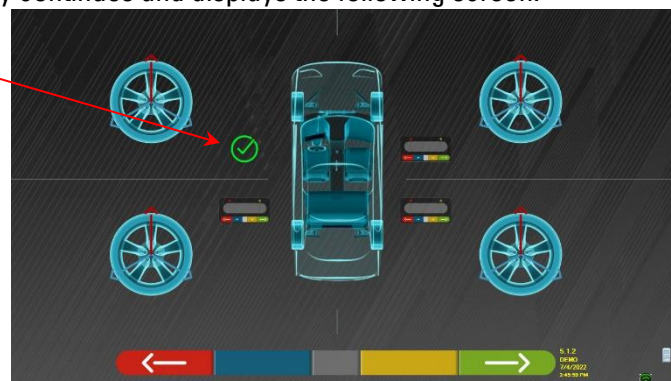

Figure 31

In Figure 31 the image of the front left wheel is accompanied by a tick, indicating that for that wheel, the procedure is complete. The procedure can nonetheless be repeated by pressing the central key of the sensor head in question again. When the run-out has been performed on all wheels, the program automatically proceeds to the next step.

iNOTE: *The various steps can be followed by monitoring the red LED of the keypad of each sensor head: The red LED flashes when the wheel needs to be turned; the red LED turns off when one of the points are being sampled; the red LED is steadily lit when the procedure is complete.*

In the system configuration, it is possible to define that the procedure must be carried out on 3 points instead of 2, in which case the wheel is turned 3 times by 120° instead of 2 times by 180° as explained above.

7.5.2 Push run-out

To perform the push run-out, select it during preparation for the run-out stage (see para. 7.4.2 on page 22) with

the F3 key 

The following screen appears:

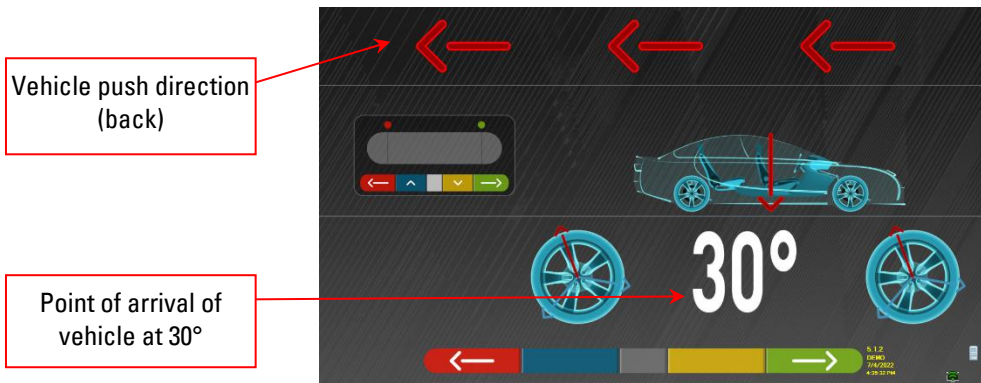

Figure 32

To perform the push run-out operation, it is advisable to carefully follow the visual instructions that appear on the screen.

⚠ ATTENTION: This procedure can be carried out correctly only if STDA35 3-point clamps are used, observing a 30° rotation in accordance with the position of the spokes.

RELEASE the sensor heads so that they are free to oscillate with the movement of the wheel. Wait for the sensor heads to stop swaying and start moving the vehicle back, very slowly, until the wheel has made a 30° rotation. This rotation can be observed on the spokes of the STDA35 3-point clamps, see figures below:

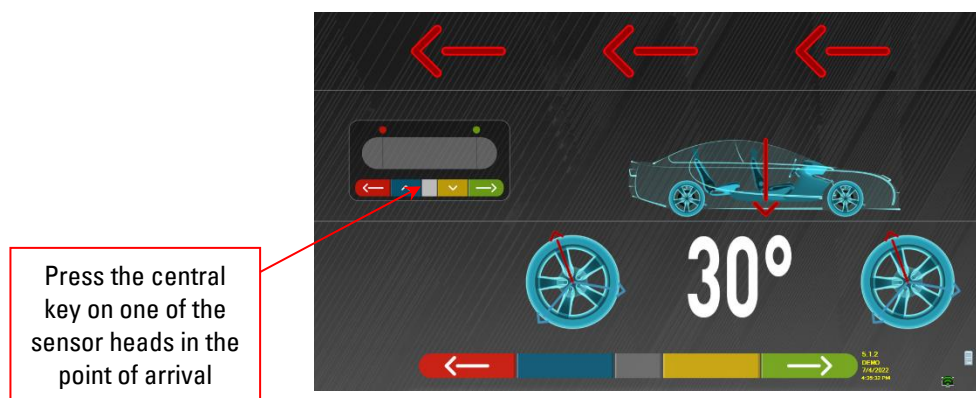
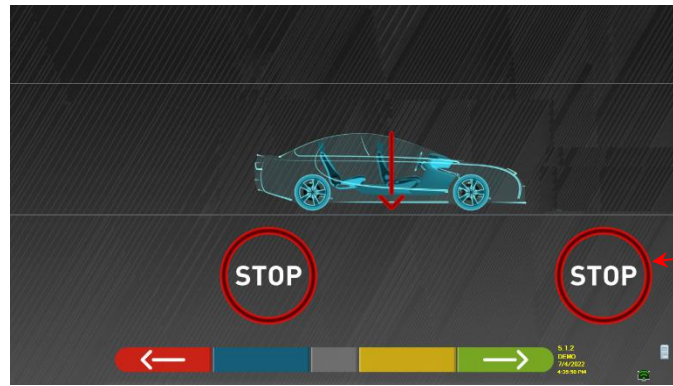

Figure 33



"STOP" is displayed for about three seconds

Figure 34

Press the central key, "STOP" appears (see Figure 34) for about three seconds, that is, the time necessary for the program to acquire the measurements, then the program shows the following screen

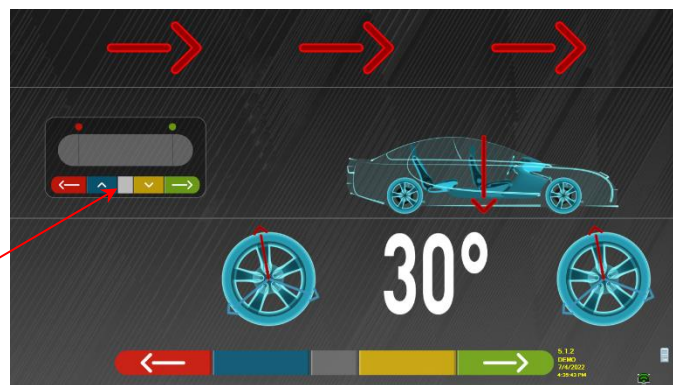

Press the central key on one of the sensor heads in the point of arrival

Figure 35

Move the vehicle forward again until the wheel has made another 30° rotation forward (end point) - the spoke of the clamp is in the vertical position again.

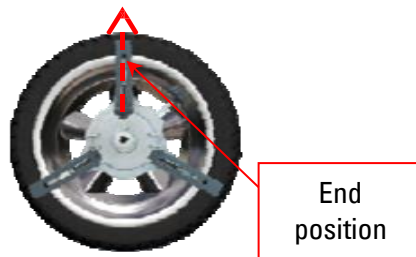

Press the central key, "STOP" appears for about three seconds, the measurements are acquired. The push run-out procedure has been performed.

To repeat the operation, having already advanced in the program, it is possible to return to this page by pressing the F1 key and then repeat the operations mentioned above.

When the run-out has been performed, the program automatically proceeds to the next step.

7.6 Preparation for measurements

After performing the run-out procedure, as explained in para. 7.5 on page 23, the vehicle needs to be prepared for the measurements. The following screen will appear:

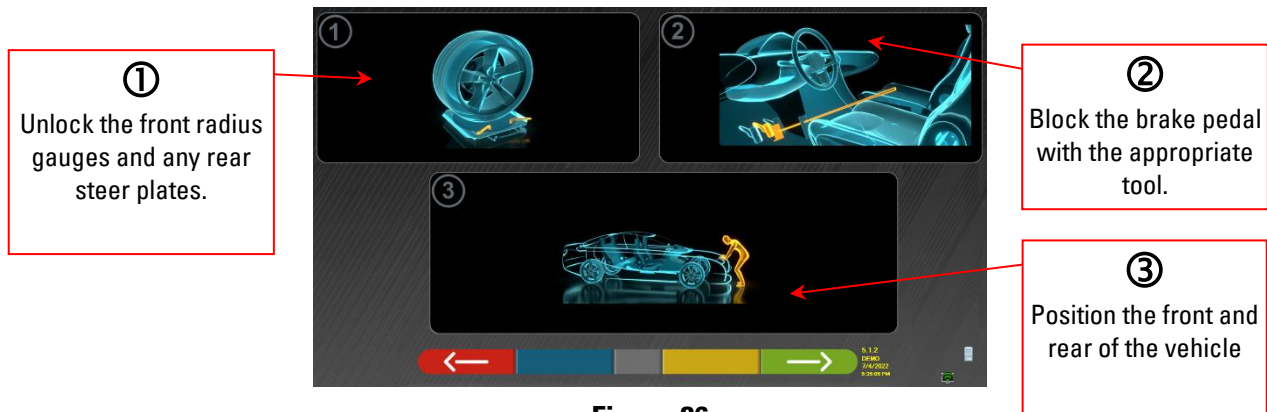



Figure 36

- 1) Unlock the front radius gauges and any rear steer plates.
- 2) Brake the wheels with the handbrake and lock the brake pedal with the appropriate tool (this is necessary if steering in order to correctly calculate the camber and caster angles).
- 3) Position the front and rear of the vehicle. This operation is necessary if the vehicle was previously raised with the suspension released (e.g. run-out execution with wheels raised).

Press the  key to return to the run-out procedure (para. 7.5 on page 23)

Press the  key to continue with the alignment procedure (para. 7.7 on page 27).

7.7 Alignment and levelling / direct measurements

After carrying out the operations to prepare for the measurements, as explained in para. 7.6 on page 27, the screen appears in Figure 37; the sensor head alignment and levelling procedure must be carried out, with the consequent detection of the direct angles:



Figure 37

Turn the steering wheel from left to right, or vice-versa, until the wheels are aligned, that is, until the display level appears in the center;

Adjust the front sensor heads until they are level and brake using the clamp knobs. The rear sensor heads must similarly be visually levelled and braked using the clamp knobs.

At the end of the sensor head alignment and levelling operations, a "STOP" sign image appears under the alignment level display: this indicates that the program is acquiring the vehicle data measurements

i NOTE: The vehicle on which the operations are being carried out may be equipped with a front Spoiler preventing the sensor heads from communicating with each other. In this case, the special “spoiler” procedure is automatically launched.

Following the graphic representation which appears on the screen, the front sensors need to be lowered so that the transducers at the end of the arm are below the spoiler. The system acquires the measurement of the front toe, after which the alignment and levelling procedure in Figure 37 is shown again. Now align and level, the program will then proceed automatically

Once alignment and levelling has been achieved, the “STOP” sign image appears indicating that the program is acquiring the vehicle data measurements. The program then proceeds automatically.

7.8 Steering procedure

After carrying out the alignment procedure (see para. 7.7 on page 27), the screen appears in Figure 38; where it is possible to carry out the steering procedure needed to determine the measurements of the angles of:

- Caster - King-pin - Incl.angle

Following the instructions on the screen, turn the steering wheel such as to bring the level of the viewer to the point of arrival highlighted in green, first to the left, then to the right and finally to the center.

After the wheels have been returned to the center, the program proceeds automatically and will show the diagnosis page (para. 7.9 on page 29).

Note: The steering procedure can also be skipped by selecting the  key: the values of the measurements indicated above will not be obtained, skipping straight to the diagnosis page (para. 7.9 on page 29).

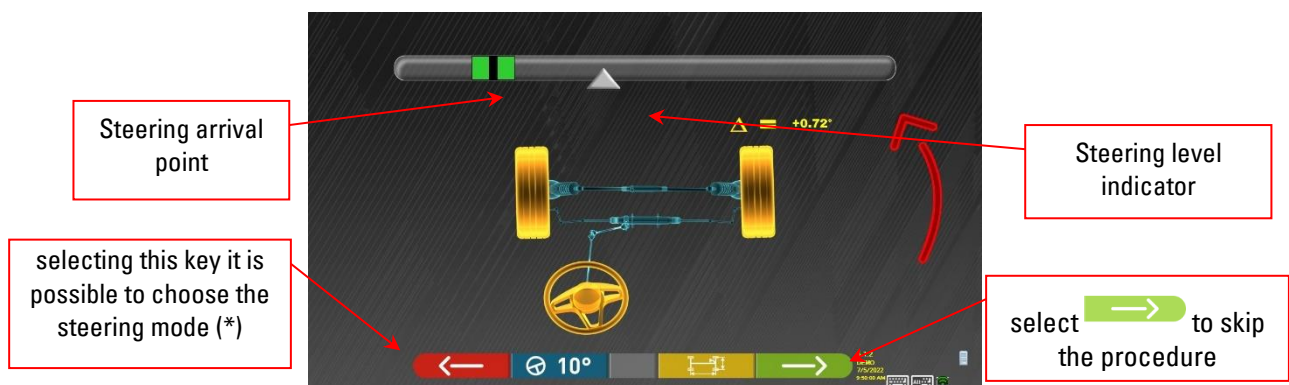







Figure 38

(*) Steering mode for acquisition of caster/king-pin

 10°	→ Steering to 10°
 20°	→ Steering to 20°
 ACK	→ ACKERMANN steering (to 20° with steering geometry)

Press the  key to display the “chassis diagnosis” (graphic-geometric representation of the vehicle axles on which the operator is working - see para. 7.13.1 on page 34).

i NOTE: by selecting the Alt+ F2 keys , a page appears (see side) where it is possible to insert the MAXIMUM STEERING values (useful to evaluate the centring of the steering box) which must be manually measured observing the values on the graduated scales on the steer plates. The aforementioned values will then be indicated in the printed report



7.9 Vehicle diagnosis

After carrying out the steering procedure (see para. 7.8 on page 28), a page appears showing the summary of the measurements taken (Figure 39).

The part on the left shows the factory reference values, on the right the diagnosis measurements are shown; the values are highlighted in green if in tolerance, in red if outside the tolerance, in grey if the tolerances are not present.

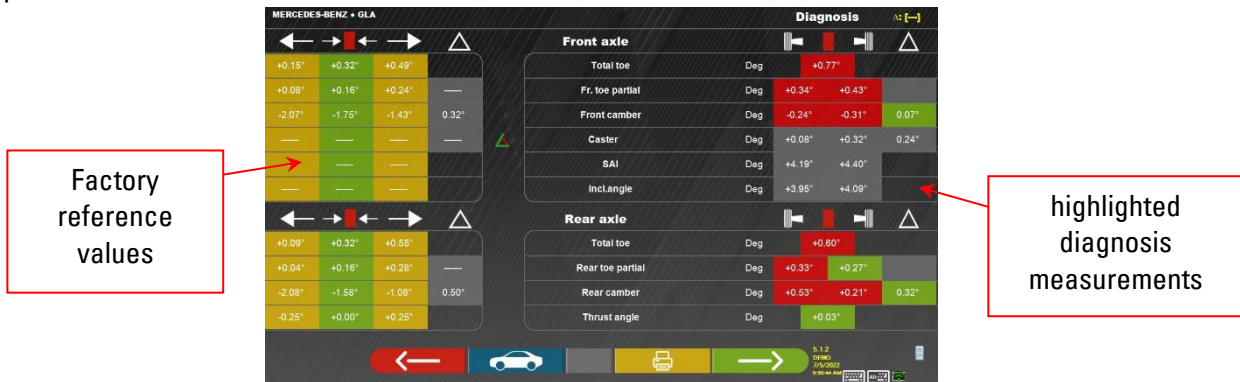





Figure 39

Press the  key to return to the steering procedure (para. 7.8 on page 28).

Press the  key to view the technical data of the selected vehicle (the model can be changed if this is found to be different).

Press the  key to view and print the diagnosis measurements.

Press the  key to continue with the preparation for adjustment (see para. 7.10 on page 29).

7.10 Preparation for adjustment

Selecting the key  from the diagnosis measurements summary page (para. 7.9 on page 29), a page appears showing the preparation for adjustment. Follow the directions that appear on the device to complete the adjustment preparation steps:

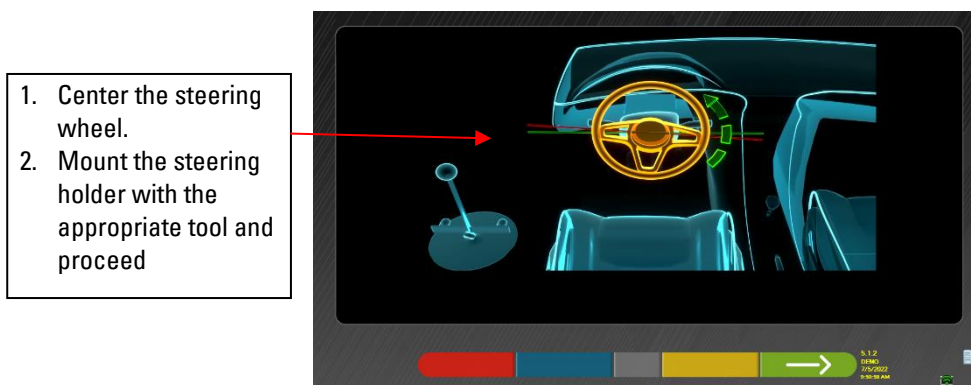



Figure 40

Press the  key to continue with adjustment of the rear axle (para. 7.11 on page 30)

7.11 Rear axle adjustment

The rear axle adjustment procedure is reached by pressing the  key in Figure 40, after performing the adjustment preparation operations (para. 7.10 on page 29).

Adjustment, where permitted, in the following order:

Rear camber - Rear partial toe (this also determines the thrust angle).



Figure 41

Press the  key to carry out the "Jack-Hold" procedure for adjustment with the wheels raised (7.12.2 on page 33).

If there are images to help with adjustment (para. 7.3.3 on page 21), press the  key to view them.

Press the  key to display the "chassis diagnosis" (graphic-geometric representation of the vehicle axles on which the operator is working - see para. 7.13.1 on page 34).



Press the key  to continue adjustment the front axle (para. 7.12 on page 30).

7.12 Front axle adjustment

The front axle adjustment procedure is reached by pressing the  key on the rear axle adjustment page (Figure 41) and after performing the adjustment preparation operations (para. 7.10 on page 29).

The recommended angle adjustment order is as follows: CASTER - CAMBER - TOE.

iNOTE: In this step, the Caster values are "Frozen" (they appear with a superimposed grid).

To "Unfreeze" the aforementioned values, it is necessary to: using the  key move the "Adjustment" selection to the caster values and then press the  key (they will now appear without the superimposed grid)

Once the caster values have been adjusted, or if they are not adjusted and are deemed to be correct, it is advisable to "Refreeze" said values by pressing the  key again.

Then perform adjustment of the front axle

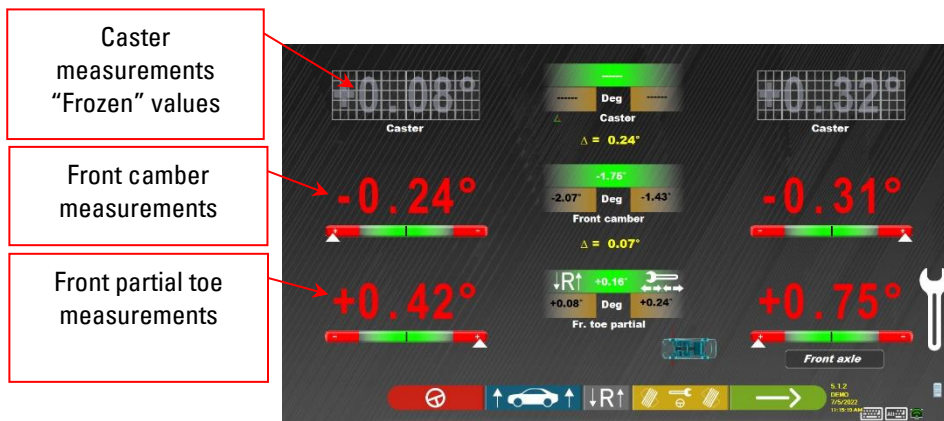





Figure 42

Press the  key to carry out the "Jack-Hold" procedure", adjustment with wheels raised (para. 7.12.2 on page 33)

Press the  key to repeat the steering procedure (para. 7.8 on page 28)

Press the  key to adjust the front toe with the wheels steered. (See para. 7.12.1 on page 32).

Press the  key to continue with the DIAGNOSIS and ADJUSTMENT data summary (para. 7.13 on page 34).

i **NOTE:** The PARTIAL TOE values can be displayed added together in order to obtain the TOTAL TOE. Press the Shift+F5 keys to alternate between the PARTIAL TOE and TOTAL TOE displays.

7.12.1 Adjustment of front toe with wheels steered

The front toe adjustment procedure with wheels steered is carried out starting from the front adjustment page (see para.7.12 on page 30), pressing the F3 key .

The Figure below appears, prompting to steer Left or Right and then press F5  to confirm.

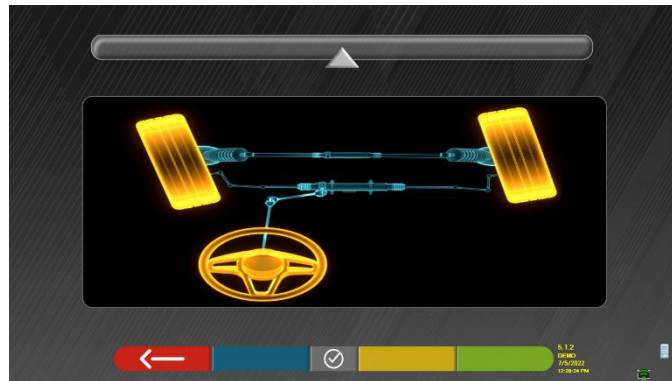





Figure 43

Note: The steering level indicator is displayed only to give the operator feedback on the value that must remain within the maximum alignment reading (approximately 20÷22°).

Once F5  has been pressed, the page appears shown in Figure 44. To adjust the partial toe, it is necessary to “unfreeze” with F2  (left partial toe) or F3  (right partial toe).

At the end of adjustment, press the F1 key  to go back in the front adjustment step (para. 7.12).

i NOTE: *The program prompts the operator to steer back to the center again before showing the front adjustment page.*

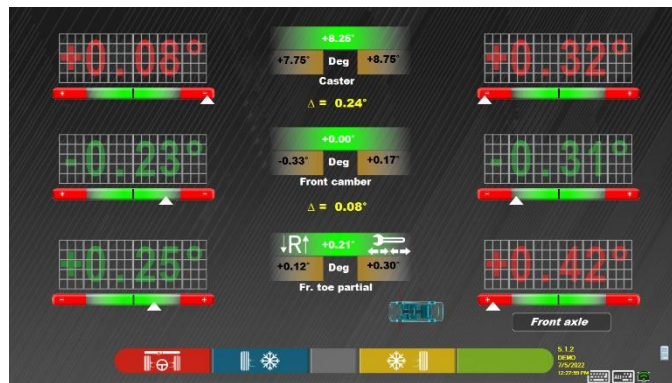



Figure 44

7.12.2 "Jack-Hold" procedure

From the front or rear adjustment page (see para. 7.11 and 7.12) press the  key to run the JACK-HOLD procedure (adjustment with wheels raised).

Follow the visual instructions that appear on the screen.

Raise the vehicle

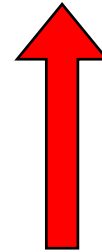
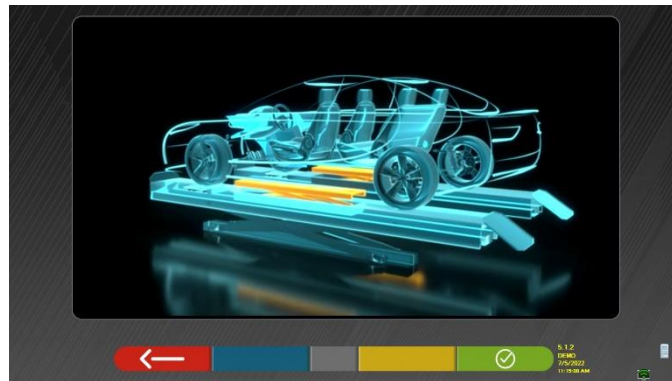
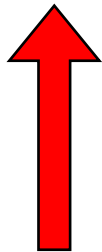





Figure 45

When the vehicle is raised, press the  key to confirm that the vehicle is effectively raised; With the vehicle raised it is now possible to perform adjustment.

By pressing the key  it is possible to pass from the rear to the front adjustment and vice-versa;



When the vehicle is raised, the  icon changes to  with the arrow facing down



Press  to switch between rear and front

Figure 46

At the end of the adjustment, press the  key to lower the vehicle and use the  key to confirm that it is correctly placed on the radius gauges/rear steer plates.

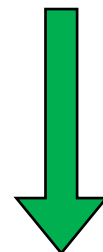
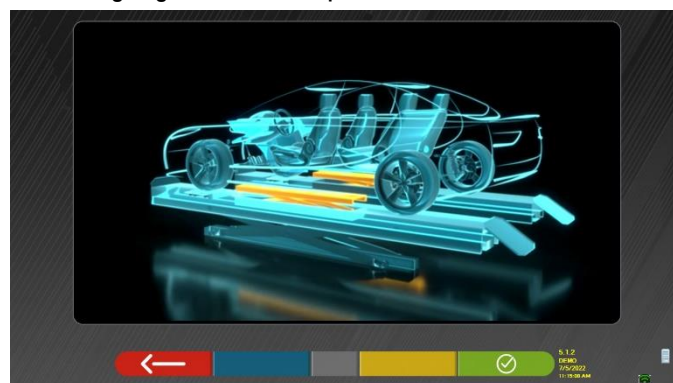
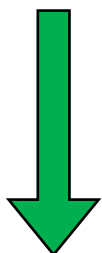



Figure 47

At this stage of adjustment, the program shows Figure 42 again (see para. 7.12 on page 30) press the  key to view the final summary (para. 7.13 on page 34)

7.13 DIAGNOSIS and ADJUSTMENT data summary

When the front adjustment procedure is finished (see Figure 42 on page 31), after the  key is pressed, the page in Figure 48 appears with a summary of the Diagnosis and Adjustment

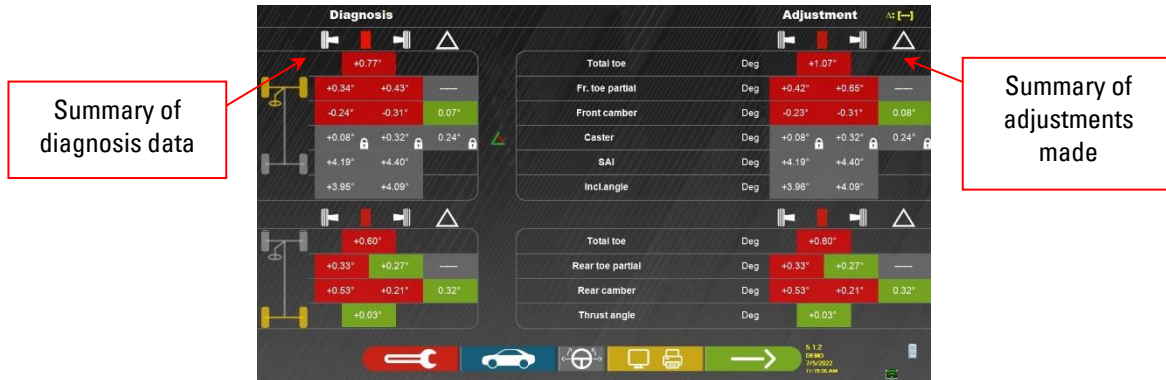







Figure 48

When the  key is pressed, the program opens the auxiliary options menu (see para. 7.14 on page 36)

Press the  key to view the technical data of the selected vehicle (the model can be changed if this is found to be different).

When the  key is pressed, the program opens the "Test Drive" procedure (para.7.13.2 on page 35)

When the  key is pressed, the program goes to the vehicle and customer data input step (see Figure 53 on page 37) where it is possible to print and eventually save the tests (see also "TEq-Link" saving - para. 7.16 on page 42).

Press the  key to return to the rear adjustment step (para. 7.11 on page 30).

7.13.1 Chassis diagnosis



In the steering procedure step (para. 7.8 on page 28) and on the rear adjustment page (para. 7.11 on page 30), when the  key is pressed, a graphic-geometric representation of the vehicle axles on which the operator is working is shown, see the example below.



Figure 49

This measurement is performed during the vehicle alignment step (see para. 7.7 on page 27). This page shows the wheelbase and track differences and the set-back of the front axle

By pressing the key  on this page, the program will allow printing of the measurements of the “Chassis Diagnosis”. Press the  key to exit and return to the previous step.

7.13.2 “Test Drive” procedure

On the Diagnosis and Adjustment summary page (para. 7.13), pressing the  key starts the “Test Drive” procedure (*) to check the correct adjustment of the partial toe, to ensure precise adjustment by observing the spokes of the steering wheel.

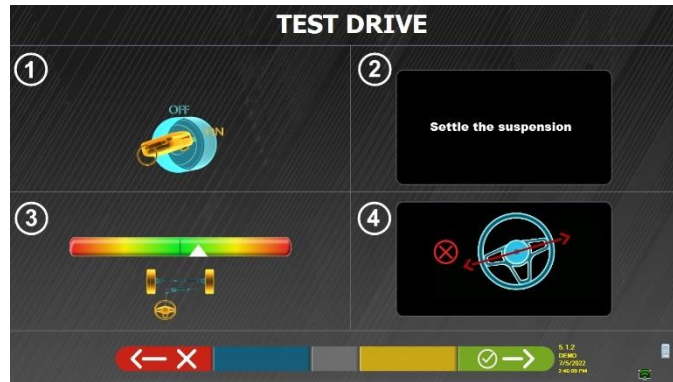

Figure 50

iNOTE the possibility to select the “Test Drive” procedure must be set in the “Settings/Procedures” menu - see chap. 6.1

- 1 - start the vehicle engine
- 2 - proceed to settle the suspension clearances, turning the steering wheel a little to the left and right
- 3 - turn the steering wheel very slowly until the cursor is exactly in the center of the alignment level bar
- 4 - Visually check that the spokes of the steering wheel are positioned correctly in a symmetrical, horizontal or consistent manner with the straight line of the vehicle.





If the spokes of the steering wheel are correctly positioned, press the  key and the program will show the page in Figure 51. In case of a negative result on the other hand, press the  key and the program will ask to carry out the partial toe adjustment procedure again, returning to the Alignment step (see chap.7.7).



Figure 51

Turn off the vehicle engine and press the  key to return to the Diagnosis and Adjustment summary step (para. 7.13).

7.14 Auxiliary functions menu

To carry out certain auxiliary operations or be able to repeat certain steps of the program if these were unsatisfactory or not carried out at all, select the F1 key  on the SUMMARY page (see para. 7.13 on page 34).

An auxiliary functions menu will open shown in Figure 52, which allows the following procedures:

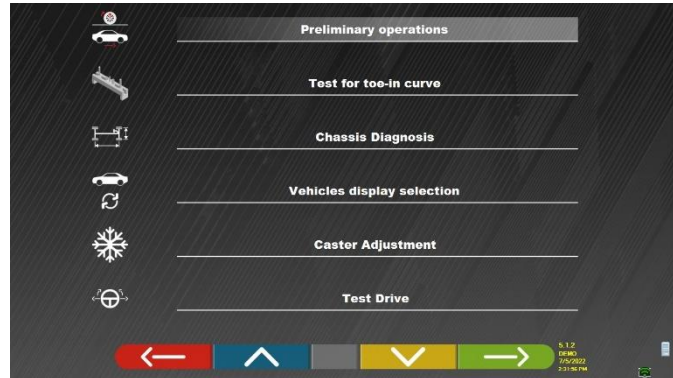





Figure 52

PRELIMINARY OPERATIONS: select to repeat all operations, starting from the preliminary operations, in order to obtain new measurements (see para. 7.4.1 on page 22)

TEST FOR TOE-IN CURVE: By following the illustrations that appear on the screen, the test for toe-in curve can be adjusted as follows:

- Adjust the vehicle, press 
- Position the relative tool under the front axle, press 
- Adjust the front partial toes as provided for by the manufacturer, press 
- Remove the tool from the axle and press , the program will return to the adjustment step.

CHASSIS DIAGNOSIS: Select to display the “chassis diagnosis” (graphic-geometric representation of the vehicle axles on which the operator is working - see para. 7.13.1 on page 34).

SHOW VEHICLE SELECTION: Opens the vehicle selection page (para. 7.3 on page 18) and allows a different vehicle to be selected

CASTER ADJUSTMENT: Select to adjust the caster values (during front adjustment these are normally “Frozen” - see para. 7.12 on page 30).

TEST DRIVE: Select to open the “Test Drive” procedure (para.7.13.2 on page 35)

7.15 Measurements print-out

Select the  key on the "SUMMARY" page (para. 7.13 on page 34), the following screen appears:

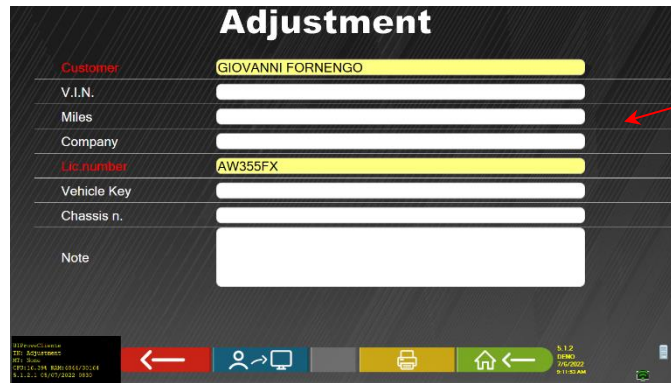

Adjustment

Customer: GIOVANNI FORNENGO

V.I.N.: _____

Miles: _____

Company: _____

Lic number: AW355FX

Vehicle Key: _____

Chassis n.: _____

Note: _____

5.12 09:00 7/6/2022 9:11:43 AM

Vehicle data and customer data entry

Figure 53

When the  key is pressed, the program opens the auxiliary options menu (see para. 7.14 on page 36)

When the  key is pressed, the test is saved in the "customer database" of tests carried out. The data in the "customer database" can be accessed from the home page (para. 7.1 on page 16)

using the F3 key 

Pressing the  key opens a preview of the print-out of the test carried out (Figure 54)

When the  key is pressed, the program returns to the initial page (para. 7.1 on page 16).

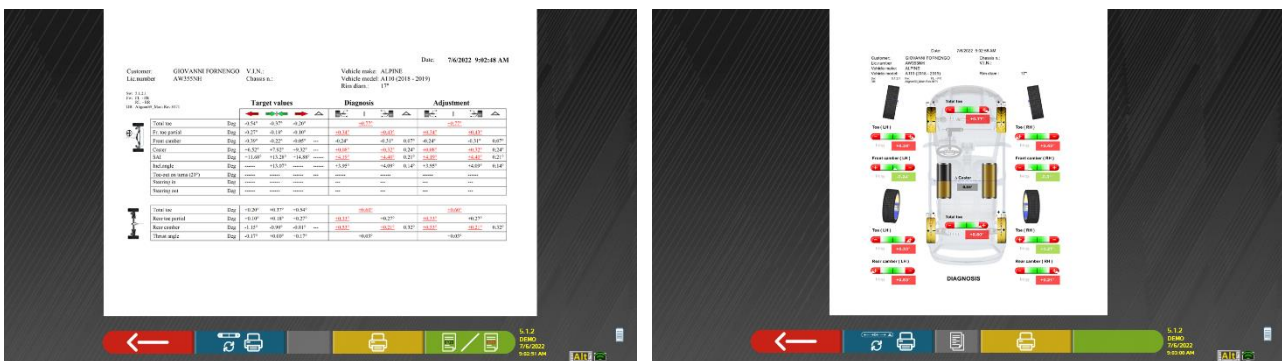



Figure 54

In the print preview (Figure 54) it is possible to switch between the Tabular print-out (example on left) and

Graphic print-out (example on right) using the  key

Press the  key to transmit the data to the printer and produce the printed report

Key to example print-out shown in Figure 55 and Figure 56

- 1 - Manufacturer's logo
- 2 - Space reserved for customisation of workshop data
- 3 - Date and time of the test
- 4 - Identification data of the vehicle being tested and of the owner
- 5 - Factory data of the vehicle being tested
- 6 - Diagnosis data of the vehicle being tested
- 7 - Data of the vehicle being tested after adjustment
- 8 - Front axle data table
- 9 - Rear axle data table
- 10 - Space reserved for notes that can be entered manually

Example of tabular printing

Customer: Johnson Tally
 Reg. number: FS258MB
 Vehicle make: ALFA ROMEO

S/w: 99.44.31.0
 Fw: LH: -
 RH: -
 DB: AlignerS9_Main Rev.6915

Date: 1/15/2019 4:16:10 PM
 V.I.N.:
 Chassis n.: BRERA 3.2 JTS (2005 - 2011)
 Vehicle:
 Rim diam.: 16"



	Nominal values		Diagnosis		Adjustment	
	[↔]	[↔]	↔	↔	↔	↔
 Total toe	Dg	-0.34°	-0.20°	-0.06°		+0.07°
Fr. toe partial	Dg	-0.17°	-0.10°	-0.08°		+0.15°
Front camber	Dg	-0.73°	-0.13°	+0.40°	0.09°	+1.75°
Caster	Dg	+3.95°	+4.55°	+0.30°	+2.83°	+4.01°
King-pin	Dg	-----	-----	-----	+9.01°	+17.68°
Incl. angle	Dg	-----	-----	-----	+10.78°	+19.36°
Toe-out on turns (20°)	Dg	-----	-----	-----	-----	+10.81°
Steering in	Dg	-----	-----	-----	-31.97°	-----
Steering out	Dg	-----	-----	-----	+29.99°	+25.50°
 Total toe	Dg	+0.31°	+0.55°	+0.25°		+0.26°
Rear toe partial	Dg	+0.16°	+0.28°	+0.12°		+0.13°
Rear camber	Dg	-1.27°	-0.67°	+0.40°	0.09°	+0.50°
Thrust angle	Dg	-0.25°	+0.25°	+0.00°		+0.00°
Track - (Front / Rear / A)	mm	1579	1559	20	1483	1486
Wheelbase - (Lh / Rh / A)	mm	2528	2528	0	2401	2406
					1483	1486
					2401	2406
						3
						5

Figure 55

Example of tabular print-out for truck

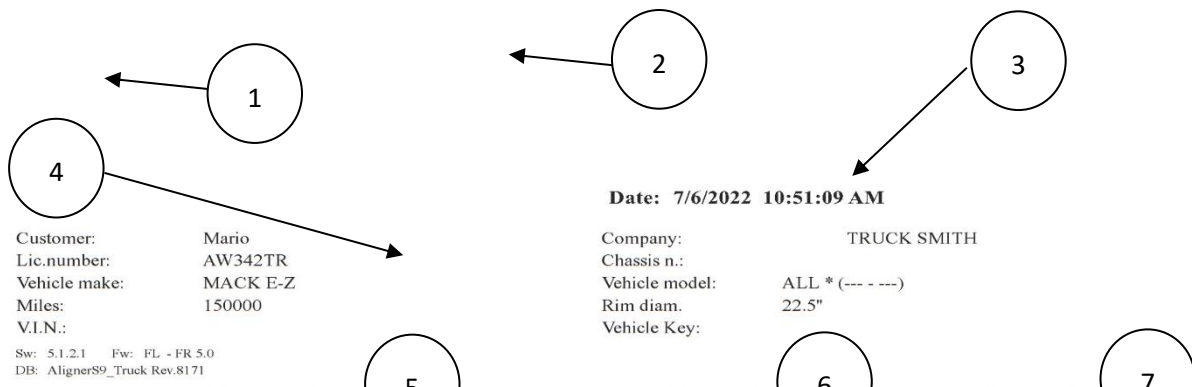

Customer: Mario
 Lic.number: AW342TR
 Vehicle make: MACK E-Z
 Miles: 150000
 V.I.N.:

Date: 7/6/2022 10:51:09 AM
 Company: TRUCK SMITH
 Chassis n.:
 Vehicle model: ALL * (--- - ---)
 Rim diam: 22.5"
 Vehicle Key:

Sw: 5.1.2.1 Fw: FL - FR 5.0
 DB: AlignerS9_Truck Rev.8171

Target values										Diagnosis				Adjustment			
Ax: 1	L/R	<=	< = >	>=	<=	< = >	>=	Δ	Lh	< = >	Rh	Δ	Lh	< = >	Rh	Δ	
Total toe	Deg	+0.04°	+0.08°	+0.12°						+0.66°				+0.66°			
Partial toe	Deg	+0.02°	+0.04°	+0.06°	+0.02°	+0.04°	+0.06°		+0.28°	+0.38°			+0.28°	+0.38°			
Camber	Deg	-0.66°	+0.00°	+0.66°	-0.66°	+0.00°	+0.66°	----	-0.25°	-0.32°	+0.07°		-0.25°	-0.32°	+0.07°		
Caster	Deg	+3.00°	+4.00°	+5.00°	+3.00°	+4.00°	+5.00°	----	+0.08°	+0.30°	+0.22°		+0.08°	+0.30°	+0.22°		
SAI	Deg	----	----	----	----	----	----		+4.25°	+4.40°			+4.25°	+4.40°			
Incl.angle	Deg	----	----	----	----	----	----		+4.00°	+4.08°			+4.00°	+4.08°			
Set-back	Deg	-0.05°	+0.00°	+0.05°						+0.13°				+0.13°			

Ax: 2	L/R	<=	< = >	>=	<=	< = >	>=	Δ	Lh	< = >	Rh	Δ	Lh	< = >	Rh	Δ
Total toe	Deg	-0.50°	+0.00°	+0.50°						+0.60°				+0.60°		
Partial toe	Deg	-0.25°	+0.00°	+0.25°	-0.25°	+0.00°	+0.25°		+0.30°	+0.30°			+0.30°	+0.30°		
Camber	Deg	-0.70°	+0.00°	+0.70°	-0.70°	+0.00°	+0.70°	----	+0.52°	+0.21°	+0.31°		+0.52°	+0.21°	+0.31°	
Thrust angle	Deg	-0.04°	+0.00°	+0.04°					+0.04°				+0.04°			
Scrub-angle	Deg	-0.04°	+0.00°	+0.04°					+0.00°				+0.00°			
Offset axle	Deg	-0.04°	+0.00°	+0.04°					+0.00°				+0.00°			
Set-back	Deg	-0.05°	+0.00°	+0.05°					----				----			

Ax: 3	L/R	<=	< = >	>=	<=	< = >	>=	Δ	Lh	< = >	Rh	Δ	Lh	< = >	Rh	Δ
Total toe	Deg	-0.50°	+0.00°	+0.50°						+0.61°				+0.61°		
Partial toe	Deg	-0.25°	+0.00°	+0.25°	-0.25°	+0.00°	+0.25°		+0.34°	+0.27°			+0.34°	+0.27°		
Camber	Deg	-0.70°	+0.00°	+0.70°	-0.70°	+0.00°	+0.70°	----	+0.52°	+0.21°	+0.31°		+0.52°	+0.21°	+0.31°	
Thrust angle	Deg	-0.04°	+0.00°	+0.04°					+0.04°				+0.04°			
Scrub-angle	Deg	-0.04°	+0.00°	+0.04°					----				----			
Offset axle	Deg	-0.04°	+0.00°	+0.04°					----				----			
Set-back	Deg	-0.05°	+0.00°	+0.05°					----				----			

Note:

Figure 56

Graphic print example



**OFFICINA MARIO BREGA
VIA ROMA 7
TORINO**

Date: 16/02/2021 14:46:47

Date/time;
Vehicle data and
customer data

Customer:	DARIO VOLPE	Chassis n.:	Y79CY9WCYCDCVJDVD
Reg.number:	FR453ET	V.I.N.:	Y79YC9WCYCDCVJDV
Vehicle make:	MERCEDES-BENZ	Miles:	34000
Vehicle:	C-CLASS (205) C450 AMG SALOON	Rim:	18"
Sw: 5.0.0.1	Fw: LH: -		
DB:	AlignerS9_Main Rev.7600		

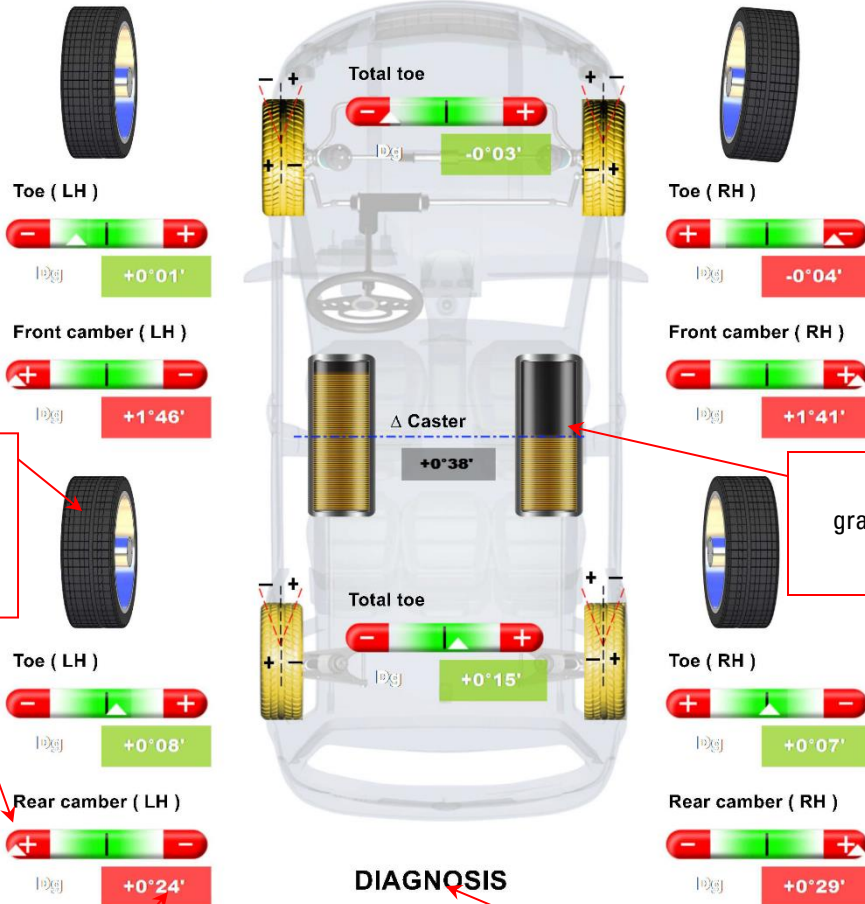

Graphical representation of the wheel based on tolerance values

Representation graph of left/right caster difference

Tolerance bar

Value indicated in red / green depending on the tolerance

Indication of diagnosis and adjustment measurements shown in red/green depending on the tolerances

DIAGNOSIS

Figure 57

Example of graphic print-out for truck

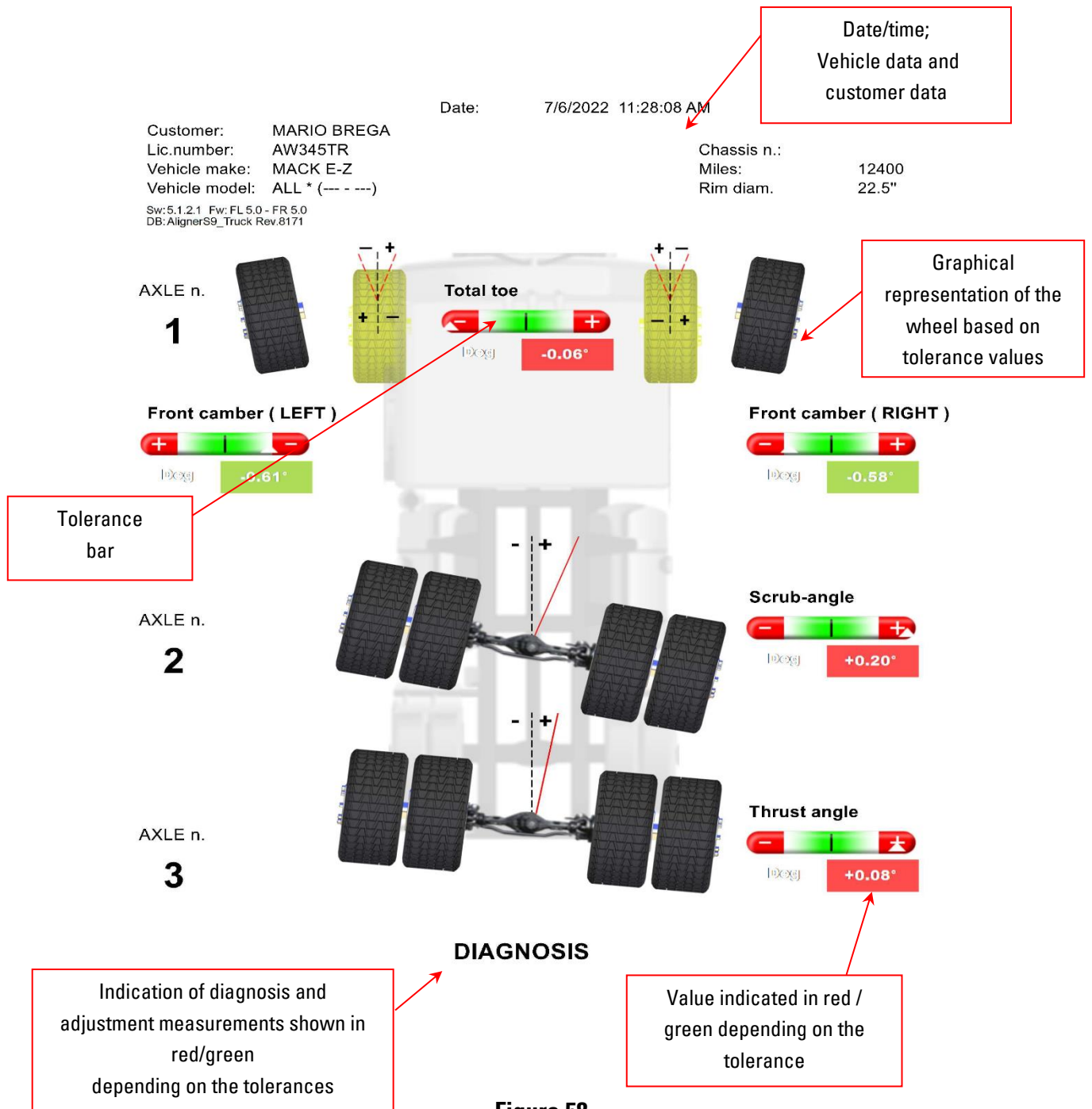



Figure 58

7.16 Saving tests carried out with TEq-Link

At the end of the test, when the vehicle and customer data is being entered (see Figure 53 on page 37), the report with the results and all vehicle data can be saved using the **TEq-Link** function. It is necessary to install the "TEq-Link Web Manager" software on a Personal Computer connected to the workshop computer network (see the TEq-Link function configuration manual cod. M0215) and to connect the PC of the equipment to the same data structure.

i NOTE: The function must first be enabled by sending a request to the manufacturer, communicating your Licence number (see Figure 3 on page 8), and the equipment PC must be configured with the references of the PC where the "TEq-Link Web Manager" software is installed.

Once the test has been carried out, when the customer data is being entered (see Figure 53 on page 37), the test result can be saved using the  key.

When the tests carried out are stored, their results are immediately accessible from any PC or mobile device in the network.

7.16.1 TEq-Link function configuration

Before being able to save the test with the TEq-Link functionality, it is necessary to insert the references of the PC where the "TEq-Link Web Manager" software is installed.

Access from the system configuration menu (see para. 6.1 on page 14) in the "application configuration" / "TEq-Link connection" option, then enter the IP address of the PC where the "TEq-Link Web Manager" software is installed.

For details see the TEq-Link function configuration manual (cod. M0215 in paragraph 3.2).

At this point, from any PC or mobile device connected to the same network, by simply inserting the IP or name of the PC with the "TEq-Link Web Manager" SW in the address bar of the browser, it is possible to access the main page from which to manage the saved tests; see example in Figure 59.

IP or name of the PC with TEq-

Saved tests

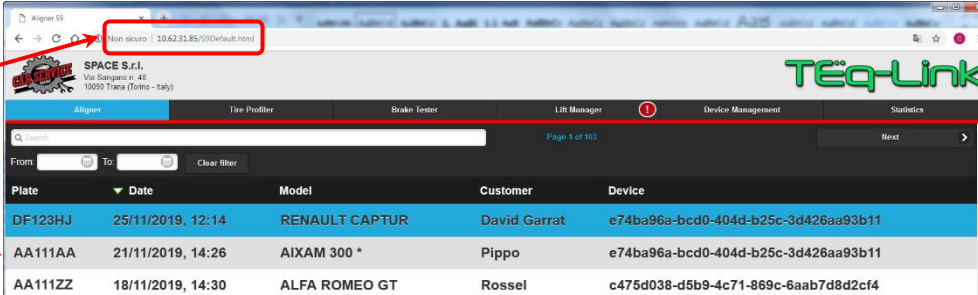

Plate	Date	Model	Customer	Device
DF123HJ	25/11/2019, 12:14	RENAULT CAPTUR	David Garrat	e74ba96a-bcd0-404d-b25c-3d426aa93b11
AA111AA	21/11/2019, 14:26	AIXAM 300 *	Pippo	e74ba96a-bcd0-404d-b25c-3d426aa93b11
AA111ZZ	18/11/2019, 14:30	ALFA ROMEO GT	Rosset	c475d038-d5b9-4c71-889c-6aab7d8d2cf4

Figure 59

8 DIAGNOSIS AND ADJUSTMENT OF TRUCKS

Several examples of heavy vehicle adjustment procedures are illustrated below. When one of these vehicles is selected from the database, it is necessary to carry out the steps described in the following chapters.

8.1 Adjustment of 3-axle tractor - 1 steering axle



From the first page of the program (Logo), press the F4 key to access the vehicle selection from the Database



Select the TRUCKS group
Press F4 to continue

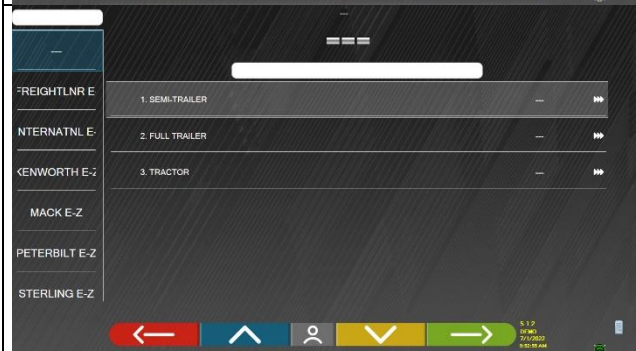

From the "TRUCKS" database, select a tractor with 1 steering axle and 2 drive axles, or select a generic truck (first in the list).
Press F4 to continue



Select "Tractor" and press F4 to continue

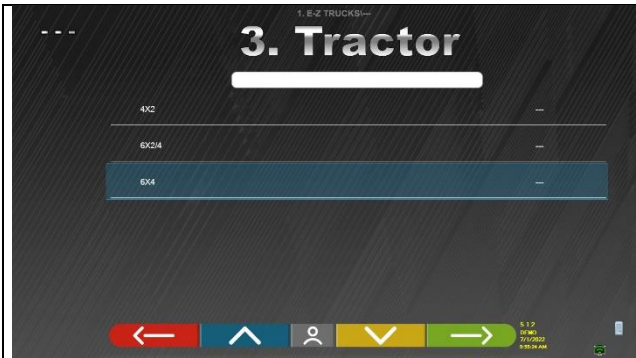

Select "Tractor 6x4", for example (6 wheels - 4 wheel drive)
Press F4 to continue

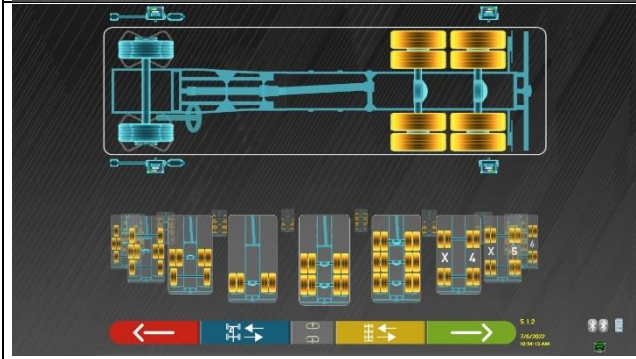

Press F4 to confirm the selected 3-axle tractor. It is possible to change the rear axle (2nd or 3rd) from which adjustment starts in order to use it as the 2nd base vehicle axle. It is necessary to press F5  .
Note: it is still possible to change the type of tractor by changing the number and arrangement of the axles with F2 and F3, or by tapping on the silhouette at the bottom

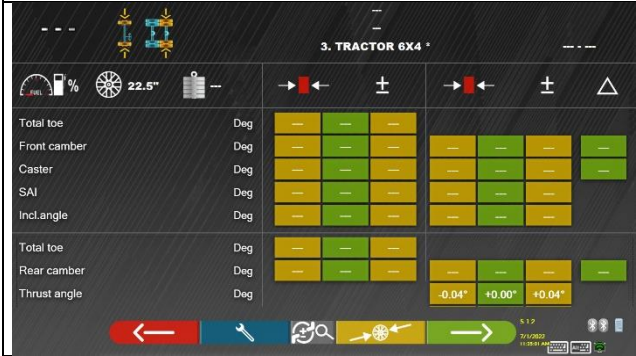

A screen appears with the measurements and tolerances provided by the manufacturer. The data shown below is for the 1st and last axle. Tap the axle in the silhouette at the top left to view the relative data

Press F4 to continue



An instruction page is shown suggesting the operations to carry out in order to prepare for adjustment; wait until the next page automatically appears or press F4 to continue.

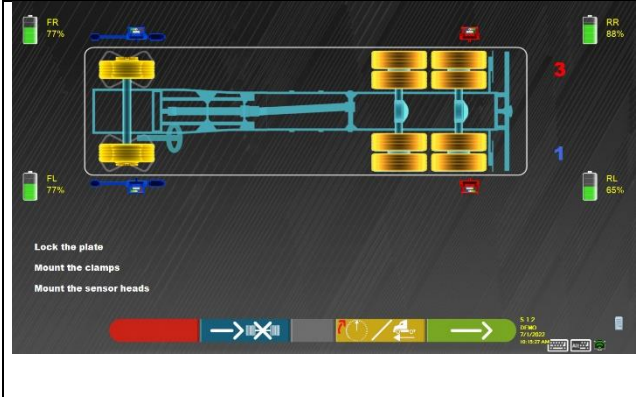

Mount the front sensor heads in the front axle
Mount the rear sensor heads in the 2nd rear axle. (the front sensors are normally illustrated in BLUE, the rear ones in red)
Press F4 to continue.

Note: The Run-out procedure can be performed in the next step. It can nonetheless be skipped using the STDA92 clamps
NOTE: The entire Run-out procedure can be disabled (settings in parameter configuration - see para. 6.1).



Turn the steering wheel until the wheels are aligned, that is, until the display level appears perfectly centred.
Adjust the front sensor heads until they are level and brake them using the special knobs.
Wait for the next page to automatically appear.

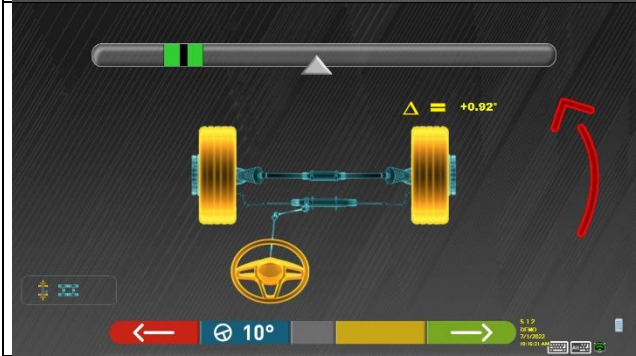

Perform the steering procedure following the indicator on the screen, first to the left, then to the right, and lastly at the center.
The steering procedure can also be skipped using the F4 key; in this case the caster data will not appear.

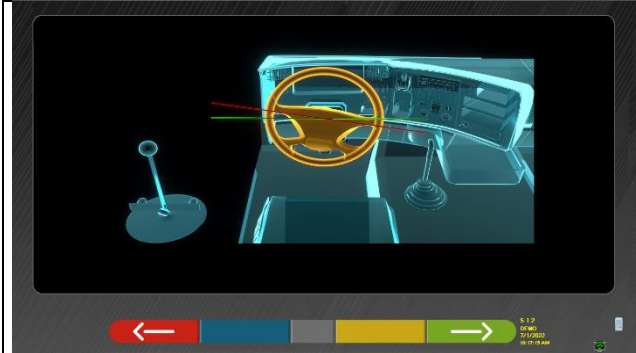

Center the steering wheel and/or center the steering box.
Mount the steering holder with the appropriate tool
Wait for the next page to automatically appear or press F4 to continue.



Adjust the rear thrust angle where possible and necessary.
Note: on this page and on every page in which the adjustable angles are indicated, pressing the "Ins" key will bring up the table shown below, which determines the shim to be inserted depending on the angle variations.
Press F4 to continue.



Take note of any shims and press F1 to return to the previous page.



Using the F3 key it is possible to zoom in and out on the partial toe values, as well as view the total toe and cambers.
Press F4 to continue.

Press Shift +F5 to view the partial toes in zoom mode and Shift +F5 again to view them in normal mode again.



Adjust the front axle, caster, camber and toe where possible and necessary.
Press F4 to continue.

Press F3 on the other hand to repeat the steering procedure or F1 to return to the rear adjustment step.

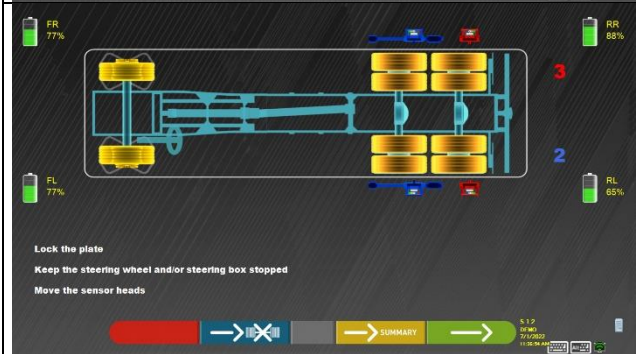

Move the front sensor heads on the 1st rear axle, press F4 to continue.
Important: keep the steering wheel and/or steering box stopped.

Note: The adjustment step for this axle can be skipped by pressing F2, or else all remaining axles can be skipped by going directly to the final results page, pressing F3.



Adjust only the front sensor heads until they are level and brake them using the special knobs. Leave the rear sensor heads in their position.
Wait for the next page to automatically appear.



Adjust the "SCRUB" angle in reference to the front axle, as shown in the Figure to the side.
In the example to the side, the 1st rear axle must be turned in an anti-clockwise direction.



When adjustment is complete, press F4 to continue.



Using the F3 key it is possible to zoom in and out on the "SCRUB" value, as well as view the total toe and cambers.
Press F4 to continue.

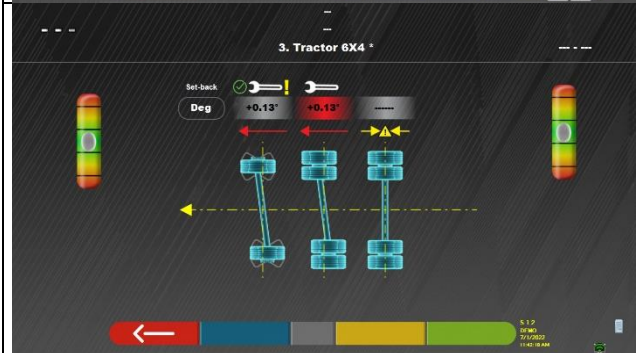

To adjust the set-back in real time ("**Set-Back LIVE**") during the adjustment of an axle, press the Alt key and another sequence of keys will appear.
Press the F3 key to view the Figure to the side showing the set-back angles in real time.
Once the angle has been adjusted, press F1 to exit.
The operator will be asked to align the wheels again before continuing.



The final summary page appears containing the Diagnosis and Adjustment data.
Press F1 to go to the page where it is possible to print or save the diagnosis and adjustment data
Press F2 to view the graphical page with the set-back data
Press F3 to select and view the data of the highlighted axle
Press F4 to select the highlighted axle to be repeated.
Attention: If the front axle is re-adjusted, the rear axles will also need to be re-adjusted as these refer to the front.

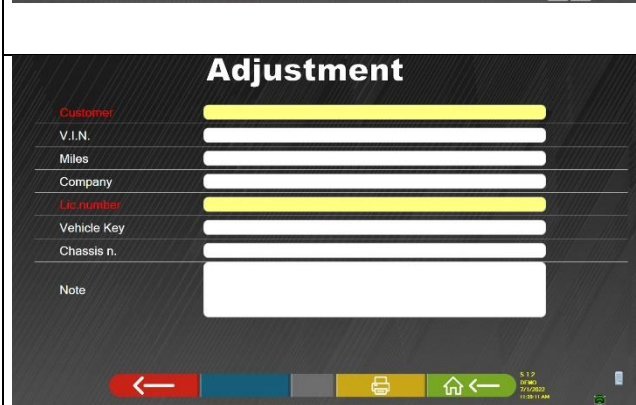

Pressing F1 opens the page shown to the side, where it is possible to print the diagnosis and adjustment data with F3, or save them in the personalised database with F2.
Press F4 to return to the introductory page (Logo).

8.2 Adjustment of a 3-axle semi-trailer

iNOTE: - IMPORTANT - For this type of adjustment, the STDA49N adapter kit for trailer alignment is required.

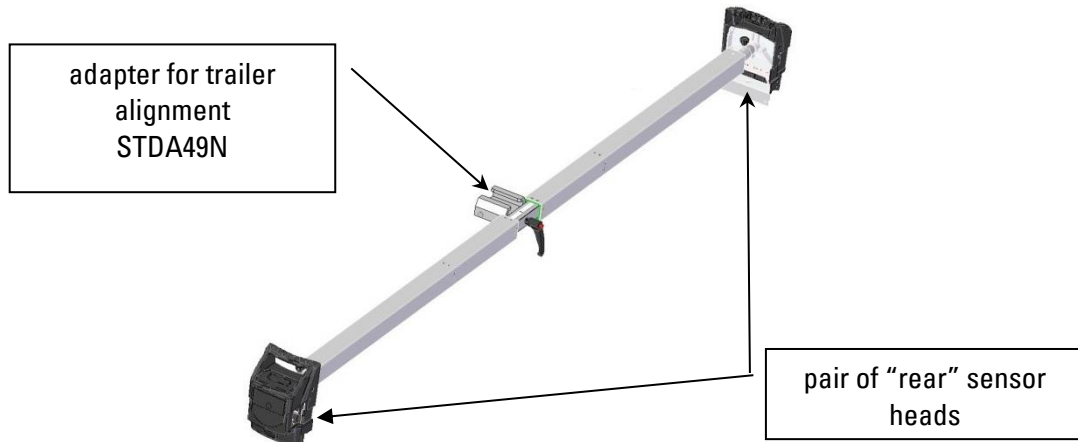

<p>The screenshot shows a menu with a list of truck types: 1. SEMI-TRAILER, 2. FULL TRAILER, and 3. TRACTOR. The "1. SEMI-TRAILER" option is highlighted.</p>	<p>Select a semi-trailer from the database</p>
<p>The screenshot shows a screen titled "1. Semi-Trailer" with a list of axle options: 1 AXLE, 2 AXLE, and 3 AXLE. The "3 AXLE" option is highlighted.</p>	<p>Select a 3-axle semi-trailer</p>
<p>The screenshot shows a top-down diagram of a 3-axle semi-trailer with three axles and six wheels. Below the diagram are several icons representing different truck configurations.</p>	<p>Press F4 to confirm the selected 3-axle semi-trailer</p> <p>Note: The selected number of axles can still be changed with the key or F3.</p>



A screen appears with the measurements and tolerances provided by the manufacturer. The data shown below refers to the highlighted axle at the top left. Tap the top left of the screen to show the data of other axles
Press F4 to continue.

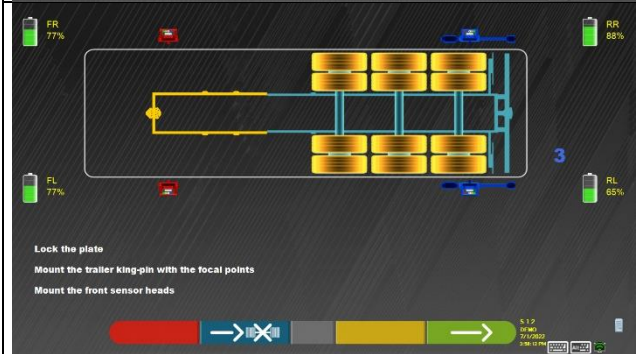

Mount the STD A49N adapter for trailer alignment
Mount the front sensor heads on the last axle of the semi-trailer.
Press F4 to continue.



Adjust the front sensor heads until they are level and brake them using the special knobs.
Wait for the next page to automatically appear.



Adjust the camber, toe and thrust angle where possible and necessary.
Press F4 to continue.

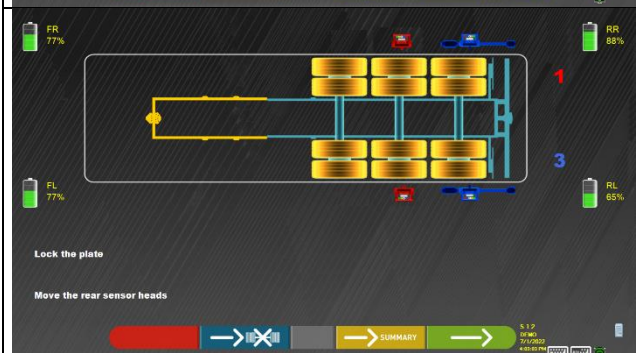

Mount the rear sensor heads in the 2nd rear axle (the front sensors are normally illustrated in BLUE, the rear ones in red)
Remove the trailer alignment adapter kit
Press F4 to continue.

Note: The adjustment step for this axle can be skipped by pressing F2, or else all remaining axles can be skipped by going directly to the final results page, pressing F3.



Adjust only the front sensor heads (mounted on the 1st rear axle) until they are level and brake them using the special knobs. Leave the front sensor heads in their position.
Wait for the next page to automatically appear.



Adjust the "SCRUB" angle in reference to the front axle, as shown in the Figure to the side.



Using the F3 key it is possible to zoom in and out on the SCRUB angle values, as well as view the toe and cambers.
Press F4 to continue.

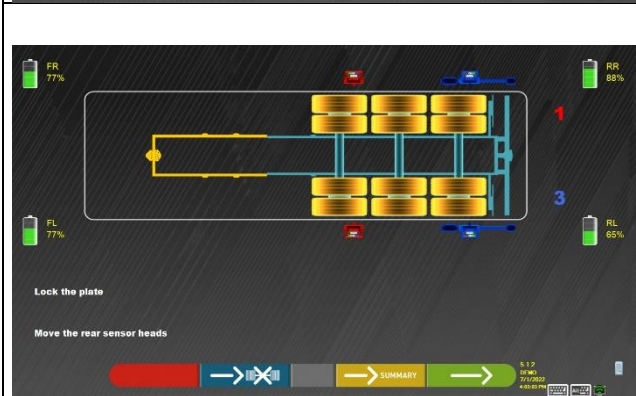

Now proceed with adjustment of the first rear axle in the same way as for the first.
Move the rear sensor heads from the 2nd axle to the 1st, Press F4.
Level the sensor heads and adjust the SCRUB angle, at the end press F4.

Note: The adjustment step for this axle can be skipped by pressing F2, or else all remaining axles can be skipped by going directly to the final results page, pressing F3.

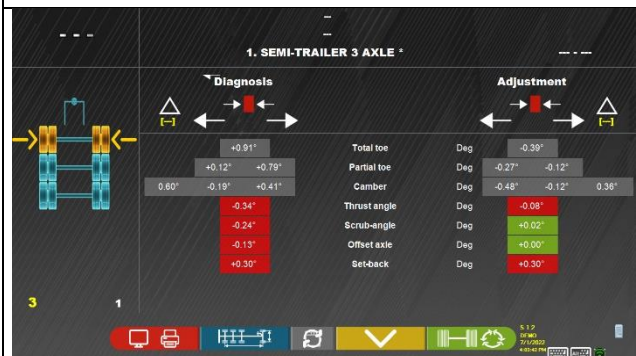

The final summary page appears shown to the side, containing the Diagnosis and Adjustment data.

Pressing F1 opens the page where it is possible to print the diagnosis and adjustment data with F2, or save them in the personalised database with F3.

8.3 Adjustment of 3-axle tractor - 2 steering axles

	<p>Select a tractor from the database</p>																																																						
	<p>Select a tractor with two steering axles</p>																																																						
	<p>Press F4 to confirm the selected tractor with two steering axles</p> <p>Note: The selected number of rear axles can be changed with the key or F3.</p>																																																						
 <table border="1" data-bbox="161 1281 799 1632"> <thead> <tr> <th></th> <th></th> <th></th> <th></th> <th></th> <th></th> </tr> </thead> <tbody> <tr> <td>Toe</td> <td>Deg</td> <td>—</td> <td>—</td> <td>—</td> <td>—</td> </tr> <tr> <td>Front camber</td> <td>Deg</td> <td>—</td> <td>—</td> <td>—</td> <td>—</td> </tr> <tr> <td>Caster</td> <td>Deg</td> <td>—</td> <td>—</td> <td>—</td> <td>—</td> </tr> <tr> <td>SAI</td> <td>Deg</td> <td>—</td> <td>—</td> <td>—</td> <td>—</td> </tr> <tr> <td>Incl. angle</td> <td>Deg</td> <td>—</td> <td>—</td> <td>—</td> <td>—</td> </tr> <tr> <td>Toe</td> <td>Deg</td> <td>—</td> <td>—</td> <td>—</td> <td>—</td> </tr> <tr> <td>Rear camber</td> <td>Deg</td> <td>—</td> <td>—</td> <td>—</td> <td>—</td> </tr> <tr> <td>Thrust angle</td> <td>Deg</td> <td></td> <td>-0.04°</td> <td>+0.00°</td> <td>+0.04°</td> </tr> </tbody> </table>							Toe	Deg	—	—	—	—	Front camber	Deg	—	—	—	—	Caster	Deg	—	—	—	—	SAI	Deg	—	—	—	—	Incl. angle	Deg	—	—	—	—	Toe	Deg	—	—	—	—	Rear camber	Deg	—	—	—	—	Thrust angle	Deg		-0.04°	+0.00°	+0.04°	<p>A screen appears with the measurements and tolerances provided by the manufacturer. The data shown is for the 1st and last axle</p> <p>Tap the desired axle in the silhouette at the top left to view the relative data</p> <p>Press F4 to continue.</p>
Toe	Deg	—	—	—	—																																																		
Front camber	Deg	—	—	—	—																																																		
Caster	Deg	—	—	—	—																																																		
SAI	Deg	—	—	—	—																																																		
Incl. angle	Deg	—	—	—	—																																																		
Toe	Deg	—	—	—	—																																																		
Rear camber	Deg	—	—	—	—																																																		
Thrust angle	Deg		-0.04°	+0.00°	+0.04°																																																		
	<p>Mount the front sensor heads in the 1st front axle</p> <p>Mount the rear sensor heads in the rear axle. (the front sensors are normally illustrated in BLUE, the rear ones in red)</p> <p>Press F4 to continue.</p>																																																						



Turn the steering wheel until the wheels are aligned, that is, until the display level appears perfectly centred.
Adjust the front sensor heads until they are level and brake them using the special knobs.
Wait for the next page to automatically appear.

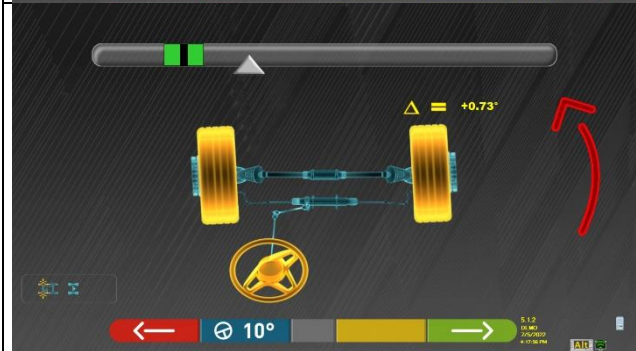

Perform the steering procedure following the indicator on the screen, first to the left, then to the right, and lastly at the center.
The steering procedure can also be skipped using the F4 key; in this case the caster data will not appear.

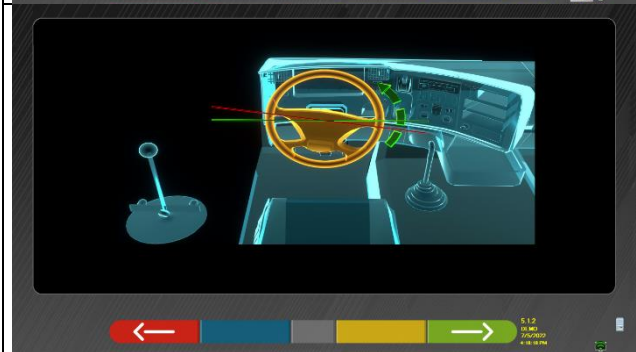

Centre the steering wheel and/or center the steering box.
Mount the steering holder with the appropriate tool
Wait for the next page to automatically appear or press F4 to continue.



Adjust the rear thrust angle where possible and necessary.
Press F4 to continue.



Using the F3 key it is possible to zoom in and out on the partial toe values, as well as view the total toe and cambers.
Press F4 to continue.



Adjust the front axle, caster, camber and toe where possible and necessary.
Press F4 to continue.

Press F2 on the other hand to repeat the steering procedure or F1 to return to the rear adjustment step.



Turn the steering wheel until the wheels are aligned, that is, until the display level appears perfectly centred.

Adjust the front sensor heads again (mounted on the first steering axle) until they are level and brake them using the special knobs.

Wait for the next page to automatically appear.

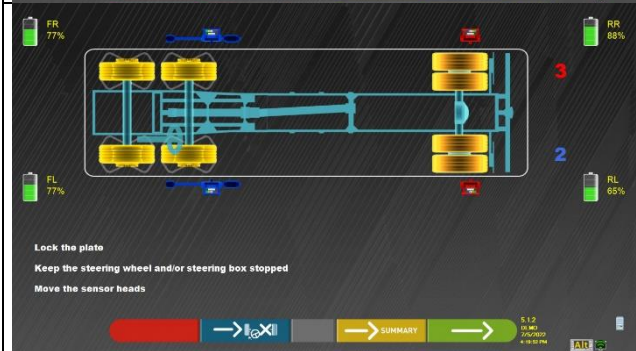

Move the front sensor heads from the 1st steering axle to the 2nd steering axle, press F4 to continue. Important: keep the steering wheel and/or steering box stopped.

Note: The steering procedure for this axle can be skipped by pressing F2, or else all remaining axles can be skipped by going directly to the final results page, pressing F3.

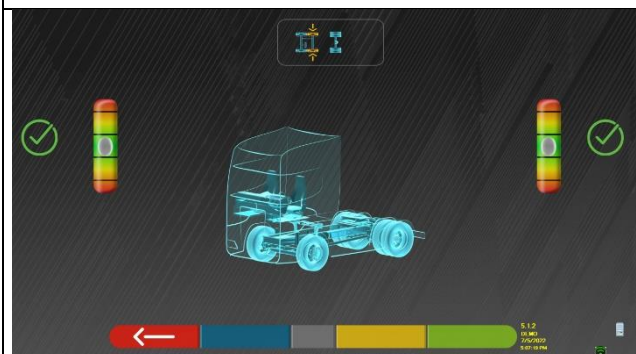

Adjust the front sensor heads (mounted on the second steering axle) until they are level and brake them using the special knobs. Leave the rear sensor heads in their position.

Wait for the next page to automatically appear.

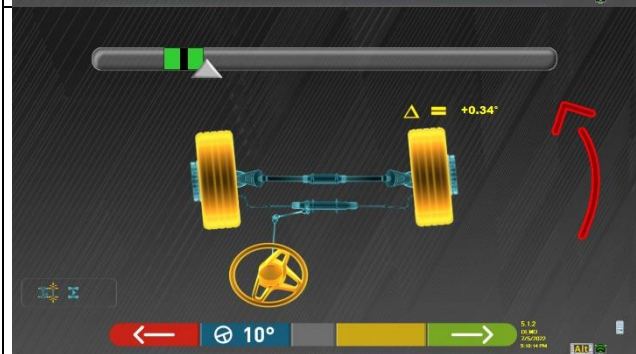

Perform the steering procedure of the 2nd steering axle following the indicator on the screen, first to the left, then to the right, and lastly at the center.

The steering procedure can also be skipped using the F4 key; in this case the caster data will not appear.



Adjust the 2nd front steering axle, caster and camber where possible and necessary.
Press F4 to continue.

Press F1 to return to the rear adjustment step.

Press F1 to return to the rear steering procedure

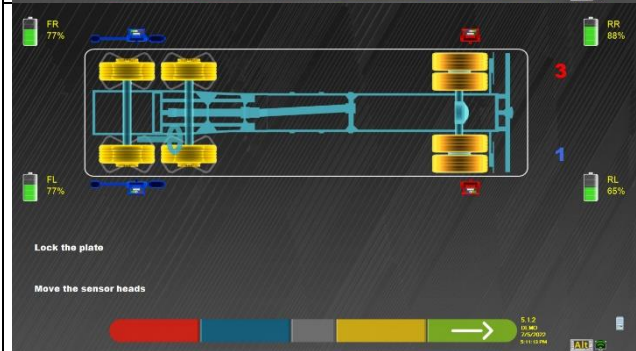

Move the front sensor heads from the 2nd steering axle to the 1st steering axle, press F4 to continue.



Turn the steering wheel until the wheels are aligned, that is, until the display level appears perfectly centred.

Adjust the front sensor heads again (mounted on the first steering axle) until they are level and brake them using the special knobs.

Wait for the next page to automatically appear.

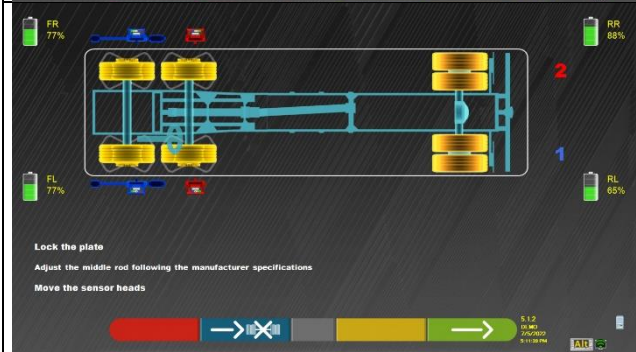

Move the rear sensor heads from the rear axle to the 2nd steering axle, press F4 to continue.

Important: keep the steering wheel and/or steering box stopped.

Note: The toe adjustment for this axle can be skipped by pressing F2, or else all remaining axles can be skipped by going directly to the final results page, pressing F3.



Position the rear sensor heads (mounted on the second steering axle) so that they are visually level and brake them using the special knobs. Leave the front sensor heads in their position.

Wait for the next page to automatically appear.



Adjust the 2nd steering axle, camber (unfreeze first) and toe where possible and necessary. Press F4 to continue.

NOTE: During this step it is not possible to adjust the caster insofar as this operation would have already been carried out.

The page then appears where it is possible to print or save the diagnosis and adjustment data



Using the F3 key  open the page showing the adjustment of the total toe.

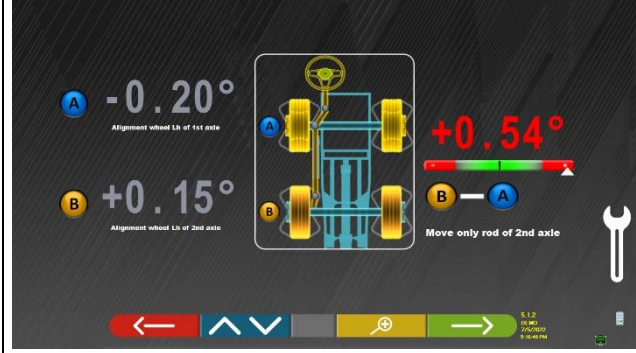

Press the F2 key  to view the page to the side and proceed with adjustment of the rod for the second steering axle, observing the display on the right.

Note: Using the rear reference axle, the procedure is requested in an additional step where the rear sensor heads need to be mounted on the second steering axle

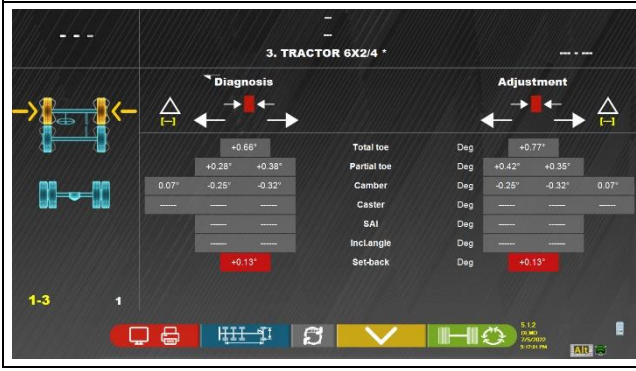

The final summary page appears containing the Diagnosis and Adjustment data.

Press F1 to go to the page where it is possible to print or save the diagnosis and adjustment data
Press F2 to view the graphical page with the set-back data



Press F3 to select and view the data of the highlighted axle

Press F4 to select the highlighted axle to be repeated.

8.4 Adjustment of a full-trailer with drawbar

i NOTE: - IMPORTANT - For this type of adjustment, the STDA49N adapter kit for trailer alignment is required.

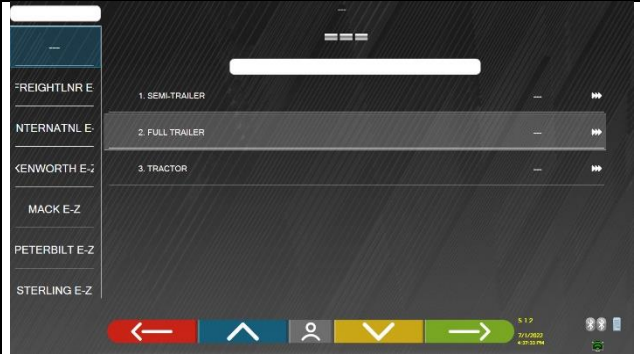

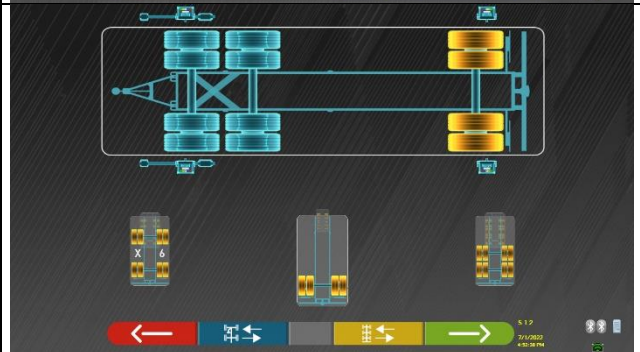
	<p>Select a Full-Trailer from the database Press F4 to continue</p>
	<p>Select a full-trailer with 2 axles on the drawbar and one rear axle Press F4 to continue</p>
	<p>Change the selected number of axles using the F2 key to select the image indicating the adjustable drawbar Press F4 to continue</p>

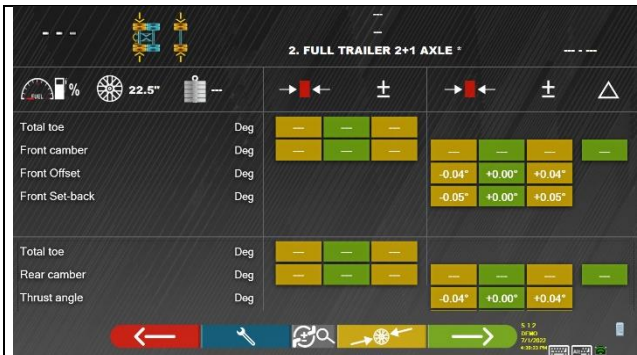

A screen appears with the measurements and tolerances provided by the manufacturer. The data shown is for the 1st and last axle.
Tap the axle in the silhouette at the top left to view the relative data

Press F4 to continue.

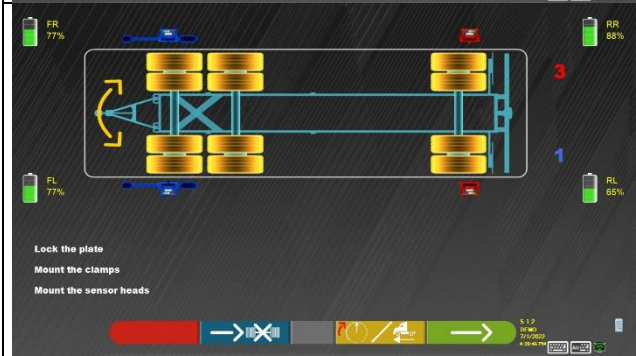

Block the plates
Mount the clamps and
Mount the front sensor heads in the 1st front axle
Mount the rear sensor heads in the rear axle.
(the front sensors are normally illustrated in BLUE, the rear ones in red)
Press F4 to continue.



Turn the drawbar until the wheels of the 1st front axle are aligned, that is, until the display level appears perfectly centred.
Adjust the sensor heads until they are level and brake them using the special knobs.
Wait for the next page to automatically appear.



Adjust the rear thrust angle where possible and necessary.
Press F4 to continue.

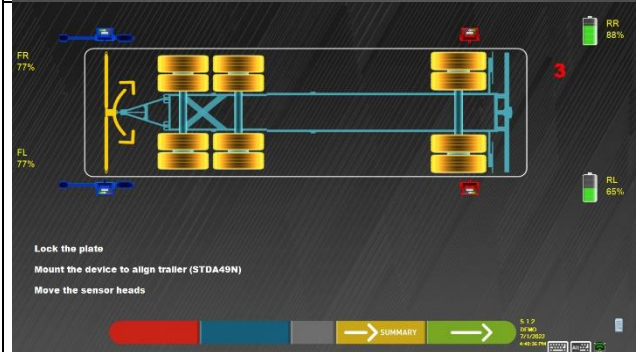

Mount the STDA49N adapter kit for trailer alignment as shown in Figure
Move the front sensor heads to the STDA49 bar and leave the rear sensor heads on the rear axle
press F4 to continue.

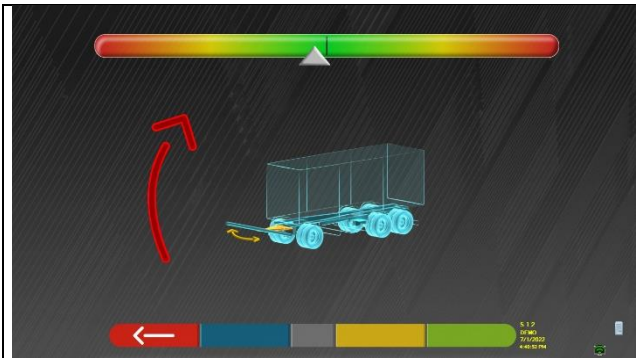

Turn the drawbar until the wheels of the 1st front axle are aligned, that is, until the display level appears perfectly centred.
The F4 key flashes, press to continue.

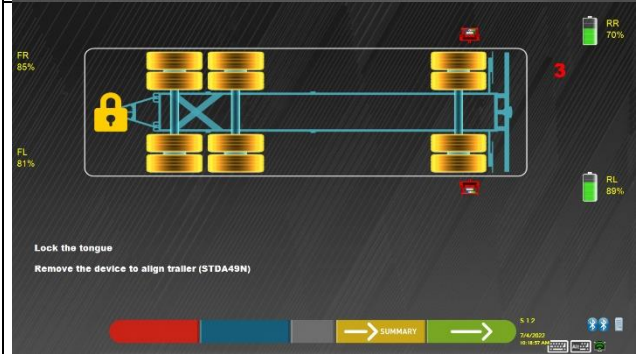

Block the drawbar and remove the STDA49N adapter for trailer alignment
Press F4 to continue.

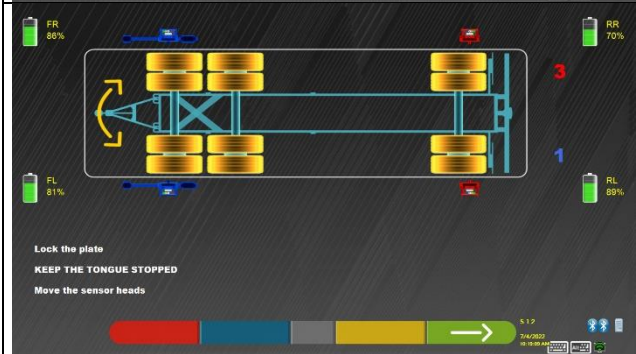

Mount the front sensor heads again in the 1st front axle
Press F4 to continue



Adjust the sensor heads only (mounted on the 1st front axle) until they are level and brake them using the special knobs, then wait for the next page to automatically appear

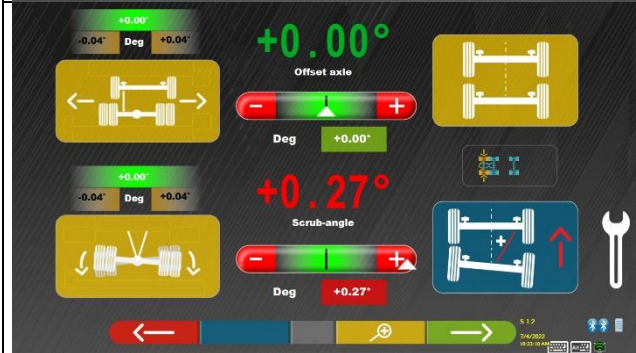

Adjust the scrub in the first front axle and eventually the offset with the F3 key the details of the toe and camber can be viewed.
Press F4 to continue.

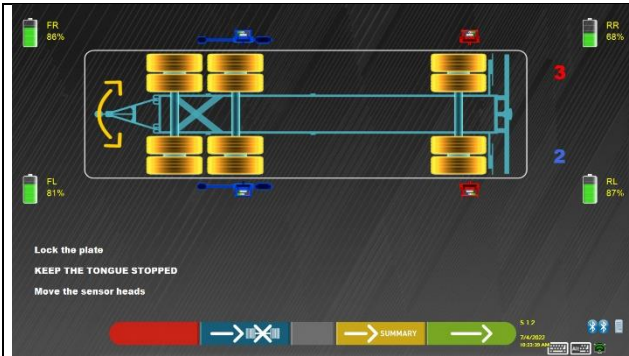

Move the front sensor heads to the 2nd front axle, press F4 to continue.

Important: keep the drawbar blocked.



Adjust the sensor heads only (mounted on the 2nd front axle) until they are level and brake them using the special knobs, then wait for the next page to automatically appear



Adjust the scrub in the second front axle and eventually the offset with the F3 key the details of the toe and camber can be viewed. Press F4 to continue.

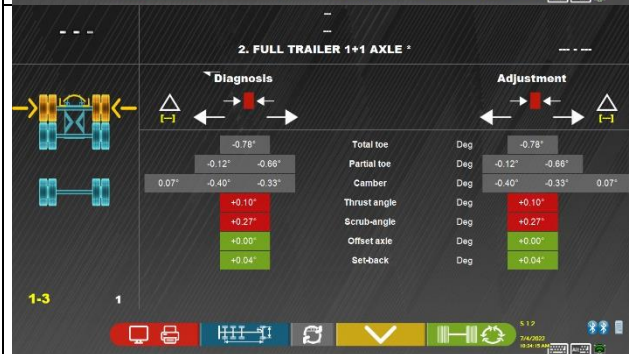

The final summary page appears containing the Diagnosis and Adjustment data. Press F1 to go to the page where it is possible to print or save the diagnosis and adjustment data. Press F2 for the setback live. Press F3 to select and view the data of the highlighted axle. Press F4 to select the highlighted axle to be repeated.

9 ERROR NOTIFICATIONS

During the transmission/reception of data between the sensor heads and cab, the following screen may appear: See Figure 60.

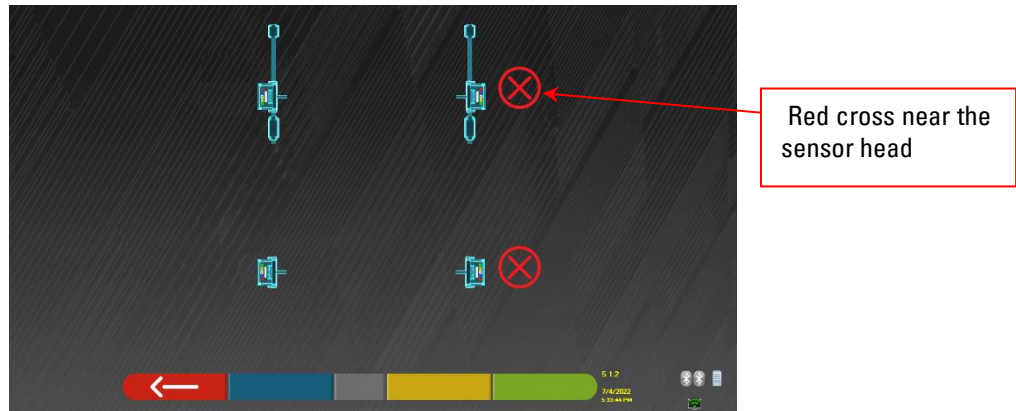

Figure 60

This means there is a transmission/reception error due to one or more of the following problems:

- The infrared transceivers of the sensor heads are not working
- There is an error or radio interference in the transmission system,
- There is an obstacle (e.g. vehicle door open) between the front and rear sensor heads

The rear sensor heads are not directly communicating with the cab: their data is transmitted/received via the front sensor heads, therefore if a front sensor head is not working properly it will be impossible to transmit the data of the corresponding rear sensor head, even if it is working properly.

If the cause of the malfunction is removed (e.g. the vehicle door is closed) the error page immediately disappears and the measurements page re-appears on the screen. If the problem persists, it is necessary to check the system hardware by first turning off the equipment

During infrared data measurement, the following screen may appear: See Figure 61

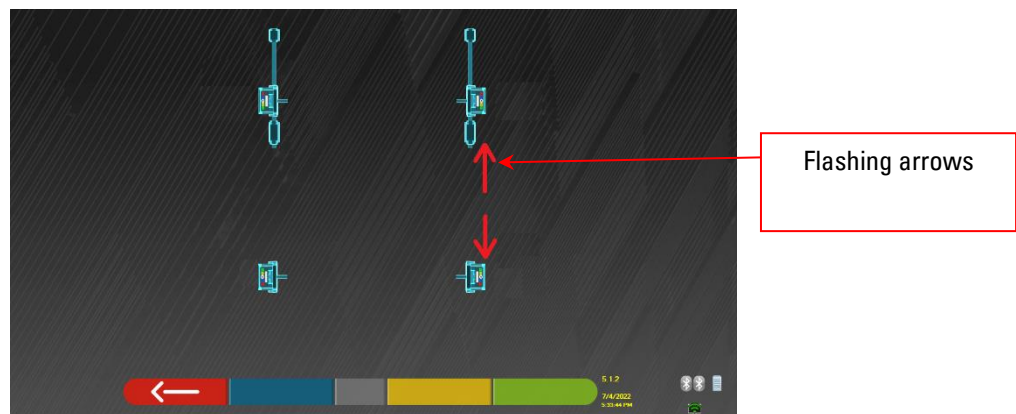

Figure 61

This error page indicates that one or more infrared measurements on the horizontal plane could not be made. There may be multiple causes:

- One or more CCD sensors (digital infrared transducer for measuring the angles on the horizontal plane) are not working.
- One or more infrared emitters for measuring the angles on the horizontal plane are not working (I.R. LED)
- There is an obstacle (e.g. vehicle door open) between the front and rear sensor heads.

If the cause of the malfunction is removed (e.g. the obstacle is removed) the error page immediately disappears and the measurements page re-appears on the tablet. If the problem persists, it is necessary to have the system hardware checked by contacting the technical assistance service.

10 PROBLEMS

Listed below are some possible problems of the wheel alignment equipment.

Rotary disclaims any liability for damage caused to persons, animals and property due to the intervention of unauthorized personnel and to the use of non-original spare parts.



WARNING

- Before carrying out any work on the system, it is necessary to disconnect the power supply.
- If in doubt, do not interpret, contact the ROTARY technical assistance in advance in order to receive information to be able to perform operations in conditions of maximum safety.

PROBLEM	CAUSE	SOLUTION
No operation on the central panel (the luminous sign does not come on, the LEDs that signal the need for battery recharge do not come on)	- No voltage in the network - Protection fuses interrupted	- Check the mains voltage - Check the protection fuses
The detectors do not turn on	- Battery completely discharged	- Recharge battery
The detectors are not reloaded on the supports	- No voltage in the network - Protection fuses interrupted	- Check the mains voltage - Check the protection fuses
The detectors are not communicating with the Tablet	- The detectors are off - Bluetooth connection not activated on the Tablet	- Turn on the detectors - Activate the Bluetooth connection on the Tablet

11 MAINTENANCE



WARNING

- Before carrying out any maintenance work, it is necessary to turn off the main switch and disconnect the equipment from the mains.
- Before connecting the power cable and turning on the equipment, make sure that the enclosure is dry and that there are no wet, damaged or dirty parts.



ATTENTION

- Do not use products that contain substances such as acetone, methyl chloride, ethyl alcohol, ammonia or ethyl acid.
- To clean plastic panels or shelves, use non-aggressive, neutral products. Do not use solvents such as synthetic thinners, benzene, alcohol or abrasive products as they may damage the surface.
- Do not clean the equipment using water jets.
- Keep the filters of the optical units clean using a slightly damp cloth, do not use solvents;
- Cleaning and other operations relating to maintenance of the Tablet are described in the manual supplied with it. Always refer to the latter before carrying out any maintenance on the Tablet.

12 STORAGE AND SCRAPPING



ATTENTION

Storage - In the event of long-term storage, it is necessary to disconnect the power sources and to provide protection for the display which could be damaged due to excessive dust deposits.

Grease the parts that could be damaged in case of drying.



ATTENTION

When it is decided to scrap this equipment, it must be made inoperative

by eliminating connection cables and susceptible parts that could become sources of danger.

All electrical and electronic equipment, marked with the symbol on the left ("rubbish bin crossed through symbol"), must be collected and disposed of separately from other mixed municipal waste through specific



collection facilities set up by public bodies or local authorities. Consider the equipment as special waste and dismantle it, dividing it into homogeneous parts.

The product meets the requirements of the directives introduced to protect the environment (2002/96/EC, 2003/108/EC, 2002/95/EC).

Correct disposal of the obsolete unit helps prevent possible negative consequences on the health of individuals and on the environment. Responsible end-of-life management of electrical and electronic equipment by users contributes to the reuse, recycling and sustainable recovery of obsolete products and related materials.

For further more detailed information on the disposal of obsolete equipment, contact the office of the municipality of residence, the waste disposal service or the Rotary after-sales service.



WARNING

- Do not dispose of the batteries in fire.

13 MACHINE IDENTIFICATION DATA/WARNING LABELS

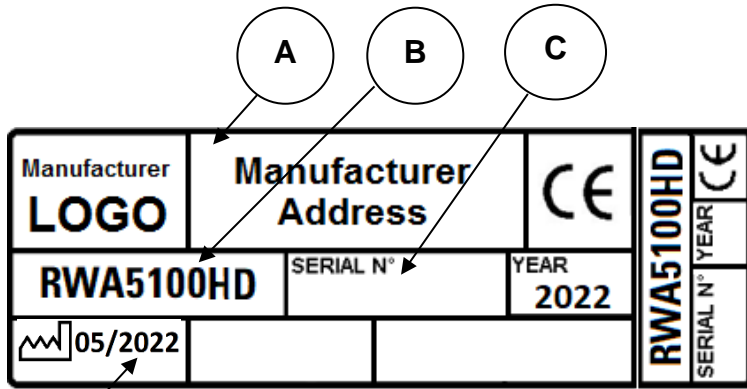

- Serial Plate
 A) Manufacturer
 B) Vehicle
 C) Serial number
 D) month/year of manufacture

Plates with data and warnings on general power supply

<p>CAUTION</p> <p>For continued protection against electric shock, this cabinet must be connected to a reliable ground connection. Do not remove the ground connection. If the receptacle in the building installation does not contain a ground pin connection, do not modify the attachment plug.</p> <p>Pour une protection continue contre les chocs électriques, cette armoire doit être reliée à une connexion de terre fiable. Ne retirez pas la connexion à la terre. Si le réceptacle de l'installation du bâtiment ne contient pas de connexion à la terre, ne modifiez pas la fiche de fixation.</p>	<p>FUSE ON NEUTRAL FUSIBLE SUR LE NEUTRE</p>
<p>CAUTION</p> <p>Risk of Electric Shock. Do Not Remove Cover. No User serviceable Parts Inside. Refer Servicing to Qualified Service Personnel.</p> <p>Risque de choc électrique, ne pas retirer le couvercle. Aucune pièce interne réparable par l'utilisateur. Confiez l'entretien à un personnel de service compétent.</p>	<p>WARNING</p> <p>Use Correct Fuse. For continued protection against risk of equipment damage and fire, replace only with fuse of specified type, current and voltage rating.</p> <p>Utilisez le fusible correcte. Pour une protection continue contre les risques d'endommagement de l'équipement et d'incendie, remplacez uniquement par un fusible de type, de tension et de courant spécifiés.</p>
<p>DANGER</p> <p>Risk of Explosion. This equipment has internal arcing or sparking parts which should not be exposed to flammable vapors. It should not be located in a recessed area or below floor level.</p> <p>Risque d'explosion. Cet équipement est composé par des pièces internes avec arcs électriques ou étincelles qui ne doivent pas être exposées à des vapeurs inflammables. Il ne doit pas être placé dans une zone encastrée ou sous le niveau du sol.</p>	

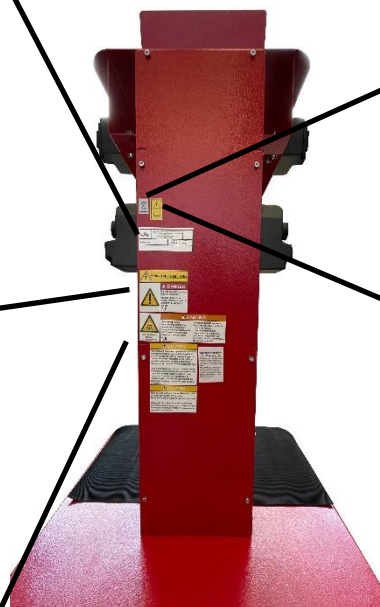

"Disposal" plate



Warning plate "Read manual"

Battery charger circuit protection fuse plate



ATTENTION

- It is absolutely forbidden to tamper with, engrave, alter in any way or even remove the machine reg. number; do not cover this plate with temporary panels, etc. as it must always be clearly visible.
- Always keep this reg. number clean from grease or dirt in general.

ATTENTION

- In the event that for accidental reasons the reg. number is damaged (detached from the machine, damaged or even partially illegible) immediately notify the manufacturer of this fact.

Installer: Please return this booklet to literature package, and give to wheel aligner owner/operator.

Thank You

Trained Operators and Regular Maintenance Ensures Satisfactory Performance of Your Wheel Service Equipment.

Contact Your Nearest Authorized Rotary Wheel Service Equipment Parts Distributor for Genuine Replacement Parts. See Literature Package for Parts Breakdown.

Rotary World Headquarters
2700 Lanier Drive
Madison, IN 47250, USA
www.rotarylif.com

North America Contact Information

Tech. Support:
p 800.445.5438
f 800.578.5438
e userlink@rotarylif.com
Sales: p 800.640.5438
f 800.578.5438
e userlink@rotarylif.com

World Wide Contact Information

World Headquarters/USA: 1.812.273.1622
Canada: 1.905.812.9920
European Headquarters/Germany: +49.771.9233.0
United Kingdom: +44.178.747.7711
Australasia: +60.3.7660.0285
Latin America / Caribbean: +54.3488.431.608
Middle East / Northern Africa: +49.771.9233.0

© Vehicle Service GroupSM

Printed in U.S.A., All Rights Reserved. Unless otherwise indicated, ROTARY, and all other trademarks are property of Dover Corporation and its affiliates.

