

# PIT LIFTS, SUSPENDED

The innovative **Portal Lift 17 Vario** is designed to meet the needs to lift buses and other heavy vehicles. It effectively combines the mounting, lift, and support operations. The rollers and structure permit it to be installed in different types and sizes of pits.

- + Free access to the pit
- + The carriage height and width adjustment make it suitable for different pit types
- + Wide range of load capacities

Lifting and lowering commands operated by a remote control connected to the overhead assembly.

Its double coating ensures perfect corrosion prevention.

Lifting is achieved through the joint operation of the side extensions and a central loading accessory that can slide over the entire crossbeam surface.

Lean design to provide maximum freedom of movement. Compact and sturdy structure for an enhanced perception of safety.

## DETAILS

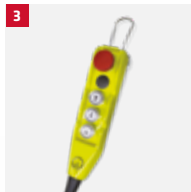

- 1 Handles for moving and optimising the positioning of the lift.
- 2 Roller bearings for easier movement.
- 3 Remote control connected to the overhead assembly for convenient control while lifting. Controls on the front and large push buttons provide easy use, even with gloves.
- 4 Central loading accessory with continuous sliding over the entire crossbeam.
- 5 Once lifting is completed, the overhead assembly can be put in "park" mode using the specific wall hooks. In this way the operator can leave the station in safe conditions, also avoiding the use of stands.
- 6 Since there is a wide range of load capacities, heavy vehicles such as lorries and buses up to a 17-tonne lifting capacity can be lifted.



**NO OBSTACLES INSIDE THE PIT**

Free access to the pit under the lifting unit so the work cycle is quicker and more user-friendly.



**SOPHISTICATED SAFETY CONCEPT**

A system of valves limits speed during the descent to make the load more stable. The automatic mechanical hook also locks the system during work operations.



# PORTAL LIFT 17 VARIO

**ADAPTABLE IN WIDTH**

Rollers extend based on the size of the pit.

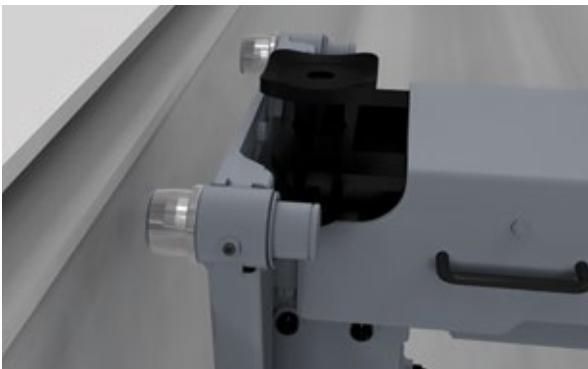

Roller and crossbeam with minimum width.



Roller and crossbeam with maximum width.

## PORTAL LIFT 17 VARIO

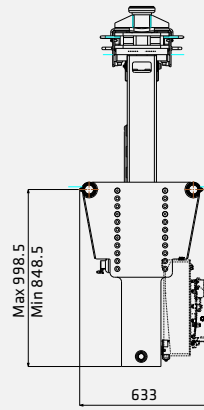
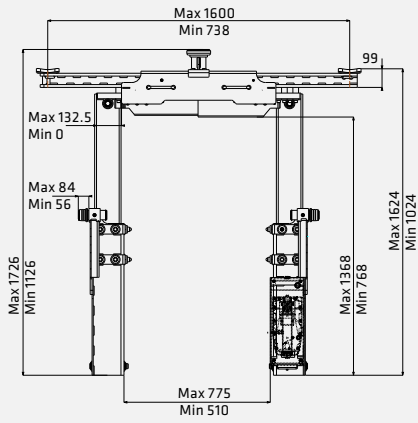

### Model

### PORTAL LIFT 17 VARIO

Item no.	130700
Capacity	17000 kg
Stroke	600 mm
Max. lifting height	600 mm
Lifting time	145 - 240 s
Lowering time	172 s
Peg diameter	60-75 mm
Air supply	8-10 bar
Surface coating	Lacquered
Undercarriage adjustment range	510 -775 mm
Weight	450 kg

### ADAPTABLE IN HEIGHT

With adjustment of the rollers, the crossbeam can be positioned flush with the floor.



Pit guide rail height at 220 mm.

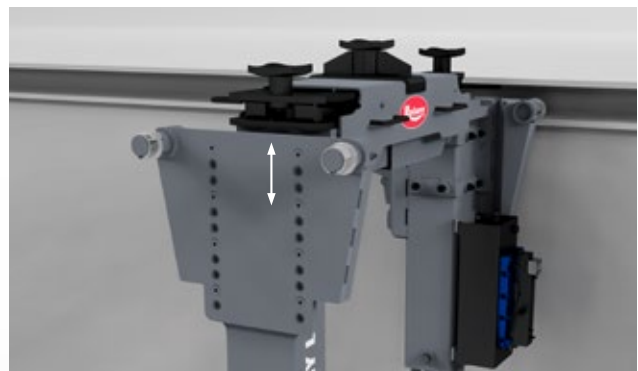

Pit guide rail height at 70 mm.

Backed by 100 years  
of experience in lifting  
technology



## ACCESSORIES



- 1 Spacer.
- 2 Frame for central load.
- 3 Accessory holder.
- 4 Steel pad.
- + Pressure regulator and dehydrator.

