

## ALLEGATO 1 AL MANUALE DI ISTRUZIONI INFORMAZIONI SUL FABBRICANTE

In tutte le parti del presente manuale nelle quali si fa riferimento, quale fabbricante, a una delle seguenti società:

- Ravaglioli S.p.A., P.IVA e C.F.: 01759471202, con sede legale in Sasso Marconi (BO), Via 1° Maggio, 3, Italia
- Butler Engineering and Marketing S.p.A., P.IVA: 01741580359, C.F.: 01824810368, con sede legale in Rolo (RE), Via dell'Ecologia, 6, Italia
- Space S.r.l., P.IVA e C.F.: 07380730015, con sede legale in Trana (TO), Via Sangano, 48, Italia

tale società deve essere intesa come:

### **Vehicle Service Group Italy S.r.l.**

P.IVA: 01426630388

C.F.: 01633631203

con sede legale in Ostellato (FE), Via Brunelleschi, 9, Italia

per effetto della intervenuta fusione per incorporazione delle citate Ravaglioli S.p.A., Butler Engineering and Marketing S.p.A. e Space S.r.l. in Officine Meccaniche Sirio S.r.l., ridenominata, a seguito della fusione, Vehicle Service Group Italy S.r.l., avente efficacia giuridica a far data dal 1° luglio 2023.

Il presente Allegato 1 al Manuale di istruzioni costituisce parte integrante del Manuale di istruzioni stesso.

Simone Ferrari

Direttore Generale



**Vehicle Service Group Italy S.r.l.**

Via Filippo Brunelleschi 9  
44020 Ostellato (FE) Italy

VAT no.: 01426630388 | Tax no.: 01633631203

## ANNEX 1 TO THE INSTRUCTION MANUAL MANUFACTURER INFORMATION

In all parts of the present manual in which reference is made to one of the following companies as the manufacturer:

- Ravaglioli S.p.A., VAT Number and Tax Code: 01759471202, with registered office in Sasso Marconi (BO), Via 1° Maggio, 3, Italy
- Butler Engineering and Marketing S.p.A., VAT Number: 01741580359, Tax Code: 01824810368, with registered office in Rolo (RE), Via dell'Ecologia, 6, Italy
- Space S.r.l., VAT Number and Tax Code: 07380730015, with registered office in Trana (TO), Via Sangano, 48, Italy

this company is to be understood as:

### **Vehicle Service Group Italy S.r.l.**

VAT Number: 01426630388

Tax Code: 01633631203

with registered office in Ostellato (FE), Via Brunelleschi, 9, Italy

as a result of the intervened merger by incorporation of the aforementioned Ravaglioli S.p.A., Butler Engineering and Marketing S.p.A. and Space S.r.l. into Officine Meccaniche Sirio S.r.l., renamed, following the merger, as Vehicle Service Group Italy S.r.l., having legal effect as of July 1<sup>st</sup>, 2023.

This Annex 1 to the Instruction Manual is an integral part of the Instruction Manual itself.

Simone Ferrari

Managing Director



**Vehicle Service Group Italy S.r.l.**

Via Filippo Brunelleschi 9  
44020 Ostellato (FE) Italy

VAT no.: 01426630388 | Tax no.: 01633631203

## ANLAGE 1 ZUR BEDIENUNGSANLEITUNG HERSTELLERANGABEN

In allen Teilen der vorliegenden Bedienungsanleitung, in denen auf eine der folgenden Gesellschaften:

- Ravaglioli S.p.A., Umsatzsteuer-Identifikationsnummer und Italienische Steuernummer: 01759471202, mit Rechtssitz in Sasso Marconi (BO), Via 1° Maggio, 3, Italien
- Butler Engineering and Marketing S.p.A., Umsatzsteuer-Identifikationsnummer 01741580359, und Italienische Steuernummer: 01824810368, mit Rechtssitz in Rolo (RE), Via dell'Ecologia, 6, Italien
- Space S.r.l., Umsatzsteuer-Identifikationsnummer und Italienische Steuernummer: 07380730015, mit Rechtssitz in Trana (TO), Via Sangano, 48, Italien

als Hersteller Bezug genommen wird, ist diese Gesellschaft zu verstehen als:

### **Vehicle Service Group Italy S.r.l.**

UMSATZSTEUER-IDENTIFIKATIONSNUMMER: 01426630388

ITALIENISCHE STEUERNUMMER: 01633631203

mit eingetragenem Rechtssitz in Ostellato (FE), Via Brunelleschi, 9, Italien

als Folge der verschmelzenden Übernahme der vorgenannten Ravaglioli S.p.A., Butler Engineering and Marketing S.p.A. und Space S.r.l. in die Officine Meccaniche Sirio S.r.l., die nach der Verschmelzung mit rechtlicher Wirkung zum 1. Juli 2023 in Vehicle Service Group Italy S.r.l. umbenannt wurde.

Die vorliegende Anlage 1 zur Bedienungsanleitung ist integrierender Bestandteil der Betriebsanleitung selbst.

Simone Ferrari

Geschäftsführer



**Vehicle Service Group Italy S.r.l.**

Via Filippo Brunelleschi 9  
44020 Ostellato (FE) Italy  
VAT no.: 01426630388 | Tax no.: 01633631203

## ANNEXE 1 DU MANUEL D'INSTRUCTIONS INFORMATIONS SUR LE FABRICANT

Dans toutes les parties de ce manuel où il est fait référence à l'une des sociétés suivantes en tant que fabricant:

- Ravaglioli S.p.A., numéro de TVA et code fiscal: 01759471202, dont le siège social est situé à Sasso Marconi (BO), Via 1° Maggio, 3, Italie
- Butler Engineering and Marketing S.p.A., numéro de TVA: 01741580359, code fiscal: 01824810368, dont le siège est à Rolo (RE), Via dell'Ecologia, 6, Italie
- Space S.r.l., numéro de TVA et code fiscal: 07380730015, dont le siège est à Trana (TO), Via Sangano, 48, Italie

cette société doit être sous-entendue comme:

### **Vehicle Service Group Italy S.r.l.**

numéro de TVA: 01426630388

code fiscal: 01633631203

dont le siège social est situé à Ostellato (FE), Via Brunelleschi, 9, Italie

à la suite de la fusion par incorporation des sociétés Ravaglioli S.p.A., Butler Engineering and Marketing S.p.A. et Space S.r.l. dans Officine Meccaniche Sirio S.r.l., renommée, à la suite de la fusion, Vehicle Service Group Italy S.r.l., avec effet juridique à compter du 1er juillet 2023.

La présente Annexe 1 au Manuel d'instructions fait partie intégrante du Manuel d'instructions lui-même.

Simone Ferrari

Directeur Général



**Vehicle Service Group Italy S.r.l.**

Via Filippo Brunelleschi 9  
44020 Ostellato (FE) Italy

VAT no.: 01426630388 | Tax no.: 01633631203

## ANEXO 1 AL MANUAL DE INSTRUCCIONES INFORMACIÓN DEL FABRICANTE

En todas las partes de este manual en las que se haga referencia a una de las siguientes empresas como fabricante:

- Ravaglioli S.p.A., número de IVA y código fiscal: 01759471202, con domicilio social en Sasso Marconi (BO), vía 1° Maggio, 3, Italia
- Butler Engineering and Marketing S.p.A., número de IVA: 01741580359, código fiscal: 01824810368, con domicilio social en Rolo (RE), vía dell'Ecologia, 6, Italia
- Space S.r.l., número de IVA y código fiscal: 07380730015, con domicilio social en Trana (TO), vía Sangano, 48, Italia

que debe entenderse por sociedad:

### **Vehicle Service Group Italy S.r.l.**

Número de IVA: 01426630388

código fiscal: 01633631203

con domicilio social en Ostellato (FE), vía Brunelleschi, 9, Italia

como resultado de la fusión por incorporación de las mencionadas Ravaglioli S.p.A., Butler Engineering and Marketing S.p.A. y Space S.r.l. en Officine Meccaniche Sirio S.r.l., rebautizada, tras la fusión, Vehicle Service Group Italy S.r.l., con efectos jurídicos a partir del 1 de julio de 2023.

El presente Anexo 1 del Manual de Instrucciones forma parte integrante del mismo.

Simone Ferrari

Director Gerente



**Vehicle Service Group Italy S.r.l.**

Via Filippo Brunelleschi 9  
44020 Ostellato (FE) Italy

VAT no.: 01426630388 | Tax no.: 01633631203

**7522-M001-17**

**NAV43.15**  
**NAV63.15**

INSTRUCTION MANUAL

EN

TRANSLATION FROM THE  
ORIGINAL INSTRUCTIONS

---

*For spare parts drawings refer to "LIST OF COMPONENTS" section.*

---

- For any further information please contact your local dealer or call:

**BUTLER ENGINEERING and MARKETING S.p.A. a s. u.**  
Via dell'Ecologia, 6 - 42047 Rolo - (RE) Italy  
Phone (+39) 0522 647911 - Fax (+39) 0522 649760 - e-mail: [Info@butler.it](mailto:Info@butler.it)

**7522-M001-17 - Rev. n. 17 (12/2021)**

**SUMMARY**

<b>GENERAL DESCRIPTION</b> _____	<b>4</b>	<b>12.2 Preliminary operations</b> _____	<b>21</b>
<b>SYMBOLS USED IN THE MANUAL</b> _____	<b>6</b>	<b>12.3 Preparing the wheel</b> _____	<b>21</b>
<b>INFORMATION PLATE LOCATION</b>		<b>12.4 Wheel clamping</b> _____	<b>22</b>
<b>DRAWING</b> _____	<b>7</b>	<b>12.5 Functioning of tools holder arm</b> _____	<b>24</b>
<b>1.0 GENERAL INTRODUCTION</b> _____	<b>9</b>	<b>12.5.1 Tools rotation</b> _____	<b>24</b>
<b>1.1 Introduction</b> _____	<b>9</b>	<b>12.5.2 Tools unit extraction/insertion</b> _____	<b>24</b>
<b>2.0 INTENDED USE</b> _____	<b>9</b>	<b>12.6 Tubeless tyres</b> _____	<b>25</b>
<b>2.1 Training of personnel</b> _____	<b>9</b>	<b>12.6.1 Bead breaking</b> _____	<b>25</b>
<b>3.0 SAFETY DEVICES</b> _____	<b>10</b>	<b>12.6.2 Demounting</b> _____	<b>26</b>
<b>3.1 Residual risks</b> _____	<b>11</b>	<b>12.6.3 Mounting</b> _____	<b>27</b>
<b>4.0 GENERAL SAFETY RULES</b> _____	<b>11</b>	<b>12.7 Tyres with inner pipe</b> _____	<b>29</b>
<b>5.0 PACKING AND MOBILIZATION FOR</b>		<b>12.7.1 Bead breaking</b> _____	<b>29</b>
<b>TRANSPORT</b> _____	<b>12</b>	<b>12.7.2 Demounting</b> _____	<b>30</b>
<b>6.0 UNPACKING</b> _____	<b>12</b>	<b>12.7.3 Mounting</b> _____	<b>31</b>
<b>7.0 MOBILIZATION</b> _____	<b>13</b>	<b>12.8 Wheels with bead wire</b> _____	<b>33</b>
<b>8.0 WORKING ENVIRONMENT</b>		<b>12.8.1 Beading and demounting</b> _____	<b>33</b>
<b>CONDITIONS</b> _____	<b>13</b>	<b>12.8.2 Mounting</b> _____	<b>34</b>
<b>8.1 Working position</b> _____	<b>13</b>	<b>13.0 ROUTINE MAINTENANCE</b> _____	<b>35</b>
<b>8.2 Installation space</b> _____	<b>13</b>	<b>13.1 Manipulator cable replacement</b> _____	<b>37</b>
<b>8.3 Lighting</b> _____	<b>14</b>	<b>14.0 TROUBLESHOOTING TABLE</b> _____	<b>38</b>
<b>9.0 MACHINE ASSEMBLY</b> _____	<b>14</b>	<b>15.0 TECHNICAL DATA</b> _____	<b>40</b>
<b>9.1 Anchoring system</b> _____	<b>14</b>	<b>15.1 Technical electrical data</b> _____	<b>40</b>
<b>10.0 ELECTRICAL CONNECTIONS</b> _____	<b>15</b>	<b>15.2 Technical mechanical data</b> _____	<b>40</b>
<b>10.1 Manipulator cable connection</b> _____	<b>16</b>	<b>16.0 STORING</b> _____	<b>43</b>
<b>10.2 Oil check on oil-pressure power unit</b> _____	<b>16</b>	<b>17.0 SCRAPPING</b> _____	<b>43</b>
<b>10.3 Check of motor rotation direction</b> _____	<b>16</b>	<b>18.0 REGISTRATION PLATE DATA</b> _____	<b>43</b>
<b>10.4 Electrical checks</b> _____	<b>17</b>	<b>19.0 FUNCTIONAL DIAGRAMS</b> _____	<b>43</b>
<b>11.0 CONTROLS</b> _____	<b>18</b>	<b>Drawing A - Wiring diagram</b> _____	<b>44</b>
<b>11.1 Control device</b> _____	<b>18</b>	<b>Drawing B - Wiring diagram (apply to</b>	
<b>11.2 Control device with bluetooth trans-</b>		<b>aerial control version)</b> _____	<b>48</b>
<b>mission (Bluetooth versions only)</b> _____	<b>19</b>	<b>Drawing C - Wiring diagram (apply to ver-</b>	
<b>11.3 Handle control in air (aerial handle</b>		<b>sion with Bluetooth handle -</b>	
<b>control versions only)</b> _____	<b>20</b>	<b>apply to 230V 50Hz 3Ph ver-</b>	
<b>12.0 USING THE MACHINE</b> _____	<b>21</b>	<b>sion - apply to 230V 60Hz 3Ph</b>	
<b>12.1 Precaution measures during tyre</b>		<b>version)</b> _____	<b>51</b>
<b>removal and fitting</b> _____	<b>21</b>	<b>Drawing D - Wiring diagram (apply to 500V</b>	
		<b>50Hz 3Ph version)</b> _____	<b>69</b>
		<b>Drawing E - Oil-pressure diagram (NAV43)</b> _____	<b>87</b>
		<b>Drawing F - Oil-pressure diagram (NAV63)</b> _____	<b>88</b>

<b>Feature /Versions</b>	<b>Model</b>	<b>NAV43</b>	<b>NAV63</b>
Power supply 400V 50Hz 3Ph		●	●
Power supply 230V 50Hz 3Ph		<b>OPT</b>	<b>OPT</b>
Power supply 500V 50Hz 3Ph			<b>OPT</b>
Power supply 230V 60Hz 3Ph		<b>OPT</b>	<b>OPT</b>
Power supply 220V 60Hz 3Ph		<b>OPT</b>	

● = standard

**OPT** = optional



### GENERAL DESCRIPTION



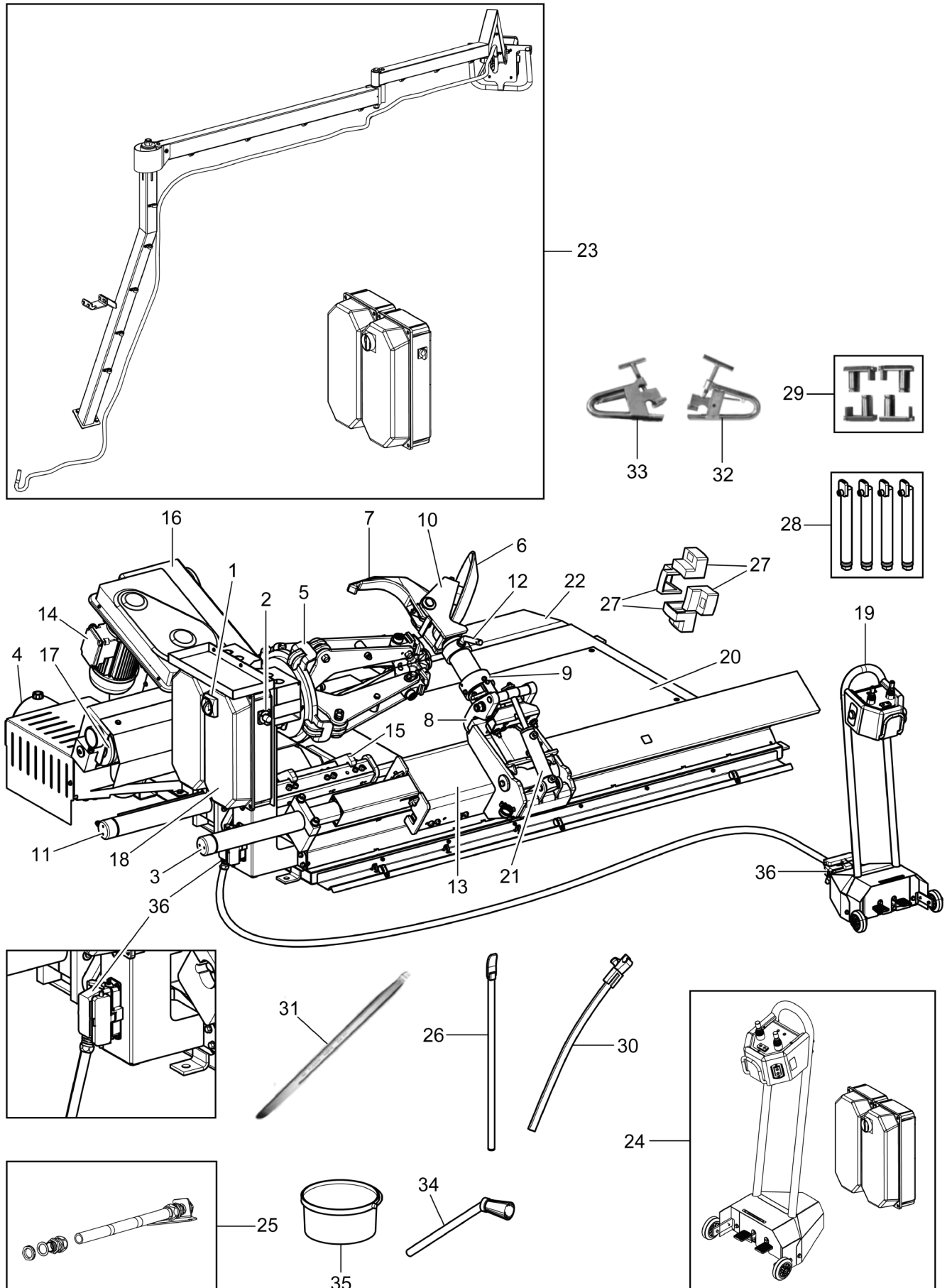



Fig. 1









**KEY (Fig. 1)**

- 1 - Main switch
- 2 - Selector 1-0-2 self-centring chuck speed control
- 3 - Tools carriage movement cylinder
- 4 - Hydraulic power unit
- 5 - Self-centring chuck
- 6 - Bead breaking disc
- 7 - Tool
- 8 - Jack
- 9 - Tools holder arm
- 10 - Tools unit
- 11 - Chuck carriage movement cylinder
- 12 - Tools unit positioning lever
- 13 - Tools carriage
- 14 - Chuck rotation motor
- 15 - Chuck carriage
- 16 - Chuck arm
- 17 - Chuck opening/closing cylinder
- 18 - Electric cabinet
- 19 - Control unit
- 20 - Platform
- 21 - Tools holder arm release cylinder
- 22 - Ramp
- 23 - Handle control in air  
(aerial handle control version)
- 24 - Control unit (bluetooth version)
- 25 - Metal sheath assembly (metal sheath version)
- 26 - Long lever "A"
- 27 - Standard clamp protections for alloy rims
- 28 - Chuck grip extensions
- 29 - Adapters with increased grip
- 30 - Bead lever
- 31 - Lever with bead wires
- 32 - Bead locking clamp for alloy rims
- 33 - Bead locking clamp for earth-moving wheels
- 34 - Brush
- 35 - Mounting grease
- 36 - Machine-manipulator connectors

**SYMBOLS USED IN THE MANUAL**

Symbols	Description
	Read instruction manual.
	Wear work gloves.
	Wear work shoes.
	Wear safety goggles.
	Mandatory. Operations or jobs to be performed compulsorily.
	Warning. Be particularly careful (possible material damages).
	Danger! Be particularly careful.

Symbols	Description
	Note. Indication and/or useful information.
	Move with fork lift truck or pallet truck.
	Lift from above.
	Technical assistance necessary. Do not perform any intervention.
	Risk of crushing and collisions (tools holder shaft).
	Danger: tyre could fall.

INFORMATION PLATE LOCATION DRAWING

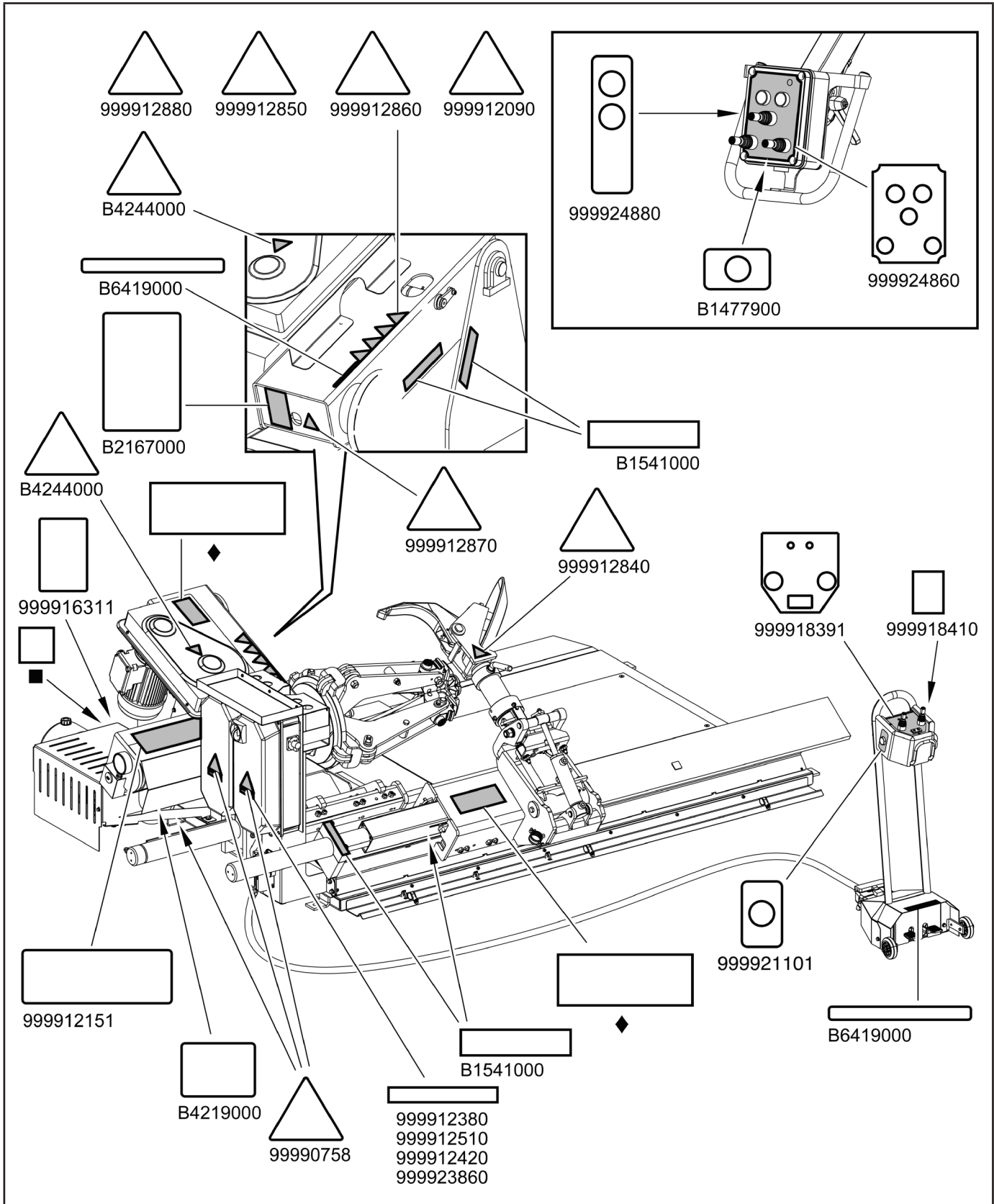

**Code numbers of plates**

<b>B1477900</b>	<i>Plate for double speed of aerial handle control (aerial control version only)</i>
<b>B1541000</b>	<i>Danger plate</i>
<b>B2167000</b>	<i>Protective clothing plate</i>
<b>B4219000</b>	<i>Rotation indicating plate</i>
<b>B4244000</b>	<i>Rotating parts danger plate</i>
<b>B6419000</b>	<i>Rotation plate</i>
<b>99990758</b>	<i>Electric shock danger plate</i>
<b>999912090</b>	<i>Danger plate 6</i>
<b>999912380</b>	<i>400V 50Hz 3Ph voltage plate</i>
<b>999912420</b>	<i>Voltage plate 220/50/3 (apply to version 220V 50Hz 3Ph)</i>
<b>999912510</b>	<i>Voltage plate 220/60/3 (apply to version 220V 60Hz 3Ph)</i>
<b>999912840</b>	<i>Danger plate 1</i>
<b>999912850</b>	<i>Danger plate 2</i>
<b>999912860</b>	<i>Danger plate 3</i>
<b>999912870</b>	<i>Danger plate 4</i>
<b>999912880</b>	<i>Danger plate 5</i>
<b>999916311</b>	<i>Rubbish skip plate</i>
<b>999918391</b>	<i>Handle control plate</i>
<b>999918410</b>	<i>Self-centring chuck plate</i>
<b>999921101</b>	<i>Double speed nameplate</i>
<b>999923860</b>	<i>Voltage plate 3Ph 500V 50Hz (500V 50Hz 3Ph version only)</i>
<b>999924860</b>	<i>Air controls plate (aerial control version only)</i>
<b>999924880</b>	<i>Tool rotation plate (aerial control version only)</i>
■	<i>QR code plate</i>
•	<i>Serial number plate</i>
*	<i>Machine nameplate</i>
◆	<i>Manufacturer plate</i>



**IF ONE OR MORE PLATES DISAPPEAR FROM THE MACHINE OR BECOMES DIFFICULT TO READ, IT MUST BE REPLACED. QUOTE THE CODE NUMBER WHEN REORDERING.**



**SOME OF THE PICTURES PRESENT IN THIS MANUAL HAVE BEEN OBTAINED FROM PICTURES OF PROTOTYPES, THEREFORE THE STANDARD PRODUCTION MACHINES AND ACCESSORIES CAN BE DIFFERENT IN SOME COMPONENTS.**

## 1.0 GENERAL INTRODUCTION

**This manual is an integral part of the product and must be retained for the whole operating life of the machine.**

Carefully study the warnings and instructions contained in this manual. It contains important instructions regarding **FUNCTIONING, SAFE USE and MAINTENANCE.**



**KEEP THE MANUAL IN A KNOWN, EASILY ACCESSIBLE PLACE FOR ALL ACCESSORY OPERATORS TO CONSULT IT WHENEVER IN DOUBT.**



**THE MANUFACTURER DISCLAIMS ALL RESPONSIBILITY FOR ANY DAMAGE OCCURRED WHEN THE INDICATIONS GIVEN IN THIS MANUAL ARE NOT RESPECTED: AS A MATTER OF FACT, THE NON-COMPLIANCE WITH SUCH INDICATIONS MIGHT LEAD TO EVEN SERIOUS DANGERS.**

### 1.1 Introduction

Thank you for purchasing this electro-hydraulic tyre changer. We feel sure you will not regret your decision. This machine has been designed for use in professional workshops and in particular it stands out for its reliability and easy, safe and rapid operation: with just a small degree of maintenance and care, this tyre changer will give you many years of trouble-free service and lots of satisfaction.

## 2.0 INTENDED USE

The machines described in this manual and their different versions are tyre changers with electro-hydraulic working, to be used only for the mounting and demounting of any type of wheel with whole rim (with groove and bead wire) , with dimension and weight values described in "Technical specifications" chapter. The machine is NOT to be used for tyre inflation.



**DANGER: EMPLOYING THESE MACHINES OUTSIDE THE USE DESTINATION THEY HAVE BEEN DESIGNED FOR (AS INDICATED IN THIS MANUAL) IS INAPPROPRIATE AND DANGEROUS.**



**THE MANUFACTURER CANNOT BE HELD RESPONSIBLE FOR ANY DAMAGE CAUSED BY IMPROPER, ERRONEOUS, OR UNACCEPTABLE USE.**

### 2.1 Training of personnel

**The machine may be operated only by suitably trained and authorized personnel.**

Given the complexity of the operations necessary to manage the machine and to carry out the operations safely and efficiently, the personnel must be trained in such a way that they learn all the information necessary to operate the machine as intended by the manufacturer.



**A CAREFUL READING OF THIS INSTRUCTION MANUAL FOR USE AND MAINTENANCE AND A SHORT PERIOD OF TRAINING WITH SKILLED PERSONNEL CAN BE ENOUGH PREVENTIVE PREPARATION.**

### 3.0 SAFETY DEVICES



**DAILY CHECK THE INTEGRITY AND THE FUNCTIONALITY OF THE SAFETY AND PROTECTION DEVICES ON THE MACHINE.**

All the machines are equipped with:

- **“man-operated” controls** (immediate stop of operation when the control is released);
- **controls logic disposition:**  
to prevent the operator from making dangerous mistakes;
- **Thermal magnetic** switch on the supply line of the oil-pressure power unit motor: avoids the motor overheating in case of intensive use;
- **controlled check valves** on:
  - opening of chuck clamps;
  - chuck arm lifting;
  - tool holder arm tilting (for versions foreseeing such operation only).These valves have been fit in order to avoid unexpected movements of the clamps, tool or chuck arm (and, as a consequence, the wheel fall) caused by accidental oil drippings;



**NO MODIFICATION OR CALIBRATION OF THE OPERATING PRESSURE OF THE MAXIMUM PRESSURE VALVE OR OF THE HYDRAULIC CIRCUIT PRESSURE LIMITER IS PERMITTED.**

- **fuses** on the power supply line of the chuck motor;
- **automatic power supply disconnection** with the opening of the electric cabinet.
- **chuck self-braking motor;**
- **fixed protections and guards.**

The machine is fitted with a number of fixed guards intended to prevent potential crushing, cutting and compression risks.

These protections have been realized after risks evaluation and after all machine operative situations have been considered.

These protections can be located in the figure below.

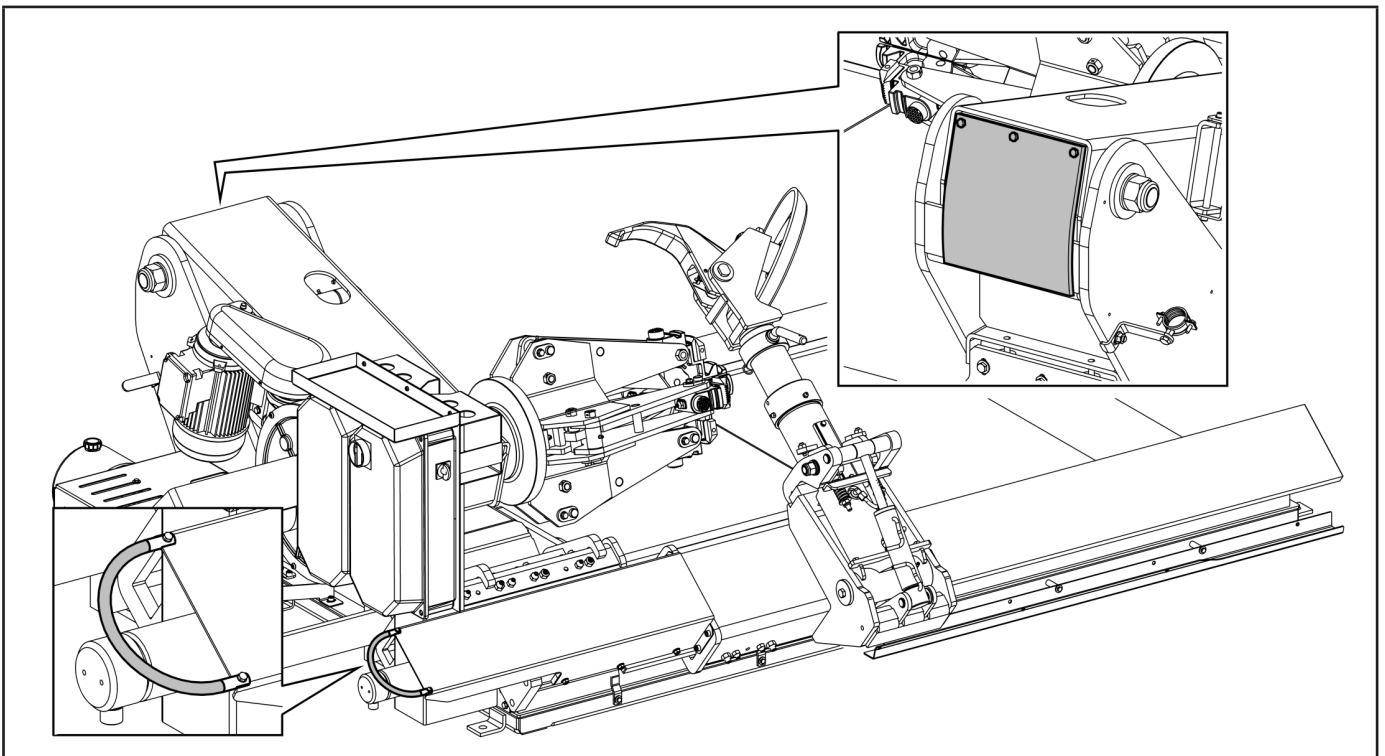

**3.1 Residual risks**

The machine was subjected to a complete analysis of risks according to reference standard EN ISO 12100. Risks are as reduced as possible in relation with technology and product functionality.

This manual stresses possible residual risks, also highlighted in pictograms on the present manual and adhesive warning signals placed on the machine: their location is represented in "LOCATION ON MACHINE INFORMATION DRAWING" on page 7.

**4.0 GENERAL SAFETY RULES**



- Any tampering with or modification to the machine not previously authorized by the manufacturer exempts the latter from all responsibility for damage caused by or derived from said actions.
- Removing of or tampering with the safety devices or with the warning signals placed on the machine leads to serious dangers and represents a transgression of European safety standards.
- Use of the machine is only permitted in places free from **explosion** or **fire** hazard and in **dry places under cover**.
- The use of only original accessories and spare parts is advised. Our machine is designed to function only with original accessories.

**THE MANUFACTURER DENIES ANY RESPONSIBILITY IN CASE OF DAMAGES CAUSED BY UNAUTHORIZED MODIFICATIONS OR BY THE USE OF NON ORIGINAL COMPONENTS OR EQUIPMENT.**

- The installation must be performed by qualified and authorized personnel in full compliance with the instructions given below.
- Ensure that there are no dangerous situations during the machine operating manoeuvres. Immediately stop the machine if it miss-functions and contact the customer service of an authorized dealer.
- In emergency situations and before carrying out any maintenance or repairs, isolate the equipment from energy sources by disconnecting the power supply using the main switch.
- The machine power supply system must be equipped with an appropriate earthing, to which the yellow-green machine protection wire must be connected.

- Ensure that the work area around the machine is free of potentially dangerous objects and that there is no oil since this could damage the tyre. Oil on the floor is also a potential danger for the operator.

**OPERATORS MUST WEAR SUITABLE WORK CLOTHES, PROTECTIVE GLASSES AND GLOVES, AGAINST THE DANGER FROM THE SPRAYING OF DANGEROUS DUST, AND POSSIBLY LOWER BACK SUPPORTS FOR THE LIFTING OF HEAVY PARTS. DANGLING OBJECTS LIKE BRACELETS MUST NOT BE WORN, AND LONG HAIR MUST BE TIED UP. FOOTWEAR SHOULD BE ADEQUATE FOR THE TYPE OF OPERATIONS TO BE CARRIED OUT.**

- The machine handles and operating grips must be kept clean and free from oil.
- The workshop must be kept clean, dry and not exposed to atmospheric agents. Make sure that the working premises are properly lit. The machine can be operated by a single operator. Unauthorized personnel must remain outside the working area, as shown in **Fig. 4**. Avoid any hazardous situations. Do not use air-operated or electrical equipment when the shop is damp or the floor slippery and do not expose such tools to atmospheric agents.
- When operating and servicing this machine, carefully follow all applicable safety and accident-prevention precautions. The machine must not be operated by untrained personnel.

**THE MACHINE OPERATES WITH PRESSURIZED HYDRAULIC FLUID. MAKE SURE EVERY COMPONENT OF THE HYDRAULIC CIRCUIT IS ALWAYS PROPERLY LOCKED, ANY PRESSURIZED LEAKS MAY CAUSE SERIOUS INJURIES OR WOUNDS.**

**IN CASE OF A CHANCE SUPPLY FAILURE (WHETHER ELECTRICITY OR OIL-PRESSURE), MOVE THE CONTROLS TO THE NEUTRAL POSITION.**



## 5.0 PACKING AND MOBILIZATION FOR TRANSPORT



HAVE THE MACHINE HANDLED BY SKILLED PERSONNEL ONLY.

THE LIFTING EQUIPMENT MUST WITHSTAND A MINIMUM RATED LOAD EQUAL TO THE WEIGHT OF THE PACKED MACHINE (SEE PARAGRAPH "TECHNICAL SPECIFICATIONS").

The machine is supplied completely assembled, packed in a cardboard box.

Movement must be by pallet-lift or fork-lift trolley.

Lift the packaging as indicated in **Fig. 2** (forks introduced in the middle to ensure a correct loads distribution).

**Fig. 2**

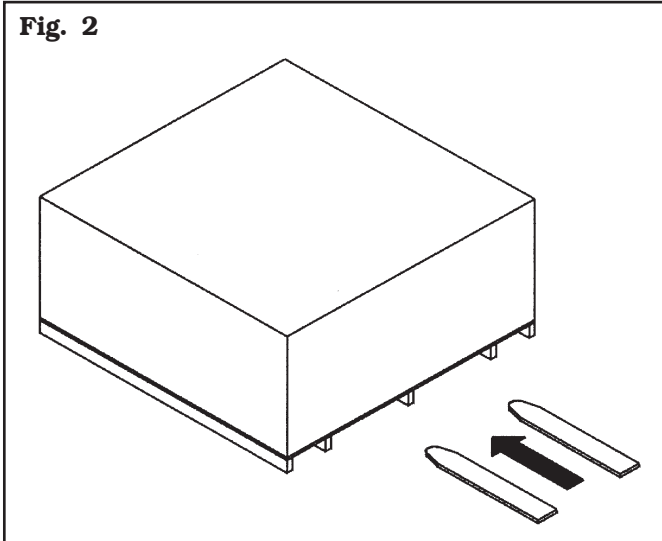

## 6.0 UNPACKING



DURING UNPACKING, ALWAYS WEAR GLOVES TO PREVENT ANY INJURY CAUSED BY CONTACT WITH PACKAGING MATERIAL (NAILS, ETC.).

After removing the packing, and in the case of the machine packed fully assembled, check that the machine is complete and that there is no visible damage. If in doubt **do not use the machine** and refer to professionally qualified personnel (to the seller). The packaging elements (plastic bags, polystyrene foam, nails, bolts, wood, etc.) must be collected up and disposed of through according to the in force laws, except for the pallet, which could be used again for subsequent machine handling.



THE BOX CONTAINING THE FIXTURES IS CONTAINED IN THE WRAPPING. DO NOT THROW IT AWAY WITH THE PACKING.

**7.0 MOBILIZATION**

If the machine has to be moved.



**THE LIFTING EQUIPMENT MUST WITHSTAND A MINIMUM RATED LOAD EQUAL TO THE WEIGHT OF THE MACHINE (SEE PARAGRAPH TECHNICAL SPECIFICATIONS). DO NOT ALLOW THE LIFTED MACHINE TO SWING.**

If the machine has to be moved from its normal work post, the movement must be conducted following the instructions listed below.

- Protect the exposed corners with suitable material (Pluribol/cardboard).
- Do not use metallic cables for lifting.
- Move the chuck to completely lowered position and in the centre of the machine in order to ensure a correct load balancing.
- Move the tool carriage to limit switch towards the chuck.
- Disconnect all machine power supply sources.
- Sling with three sufficiently long belts (300 cm - 118" at least) and with capacity load at least equal to machine weight (see Fig. 3).
- Lift and transport with suitable device with adequate dimensions.

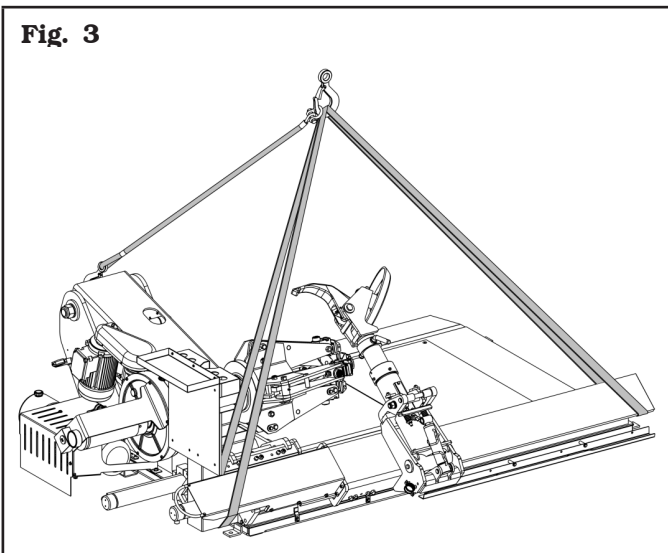

**8.0 WORKING ENVIRONMENT CONDITIONS**

The machine must be operated under proper conditions as follows:

- temperature: +5 °C ÷ +40 °C (+41 °F ÷ +104 °F)
- relative humidity: 30 - 95% (dew-free)
- atmospheric pressure: 860 - 1060 hPa (mbar) (12.5 ÷ 15.4 psi).

The use of the machine in ambient conditions other than those specified above is only allowed after prior agreement with and approval of the manufacturer.

**8.1 Working position**

In Fig. 4 it's possible to define working positions **A**, **B**, **C**, **D**, which will be referred to in the description of machine operative phases.

Positions **A** and **B** must be considered as main positions for tyre mounting and demounting and for wheel clamping on the chuck, while positions **C** and **D** are the best positions to follow tyre bead breaking and demounting operations.

Working in these positions allows better precision and speed during operating phases as well as greater safety for the operator.

**8.2 Installation space**

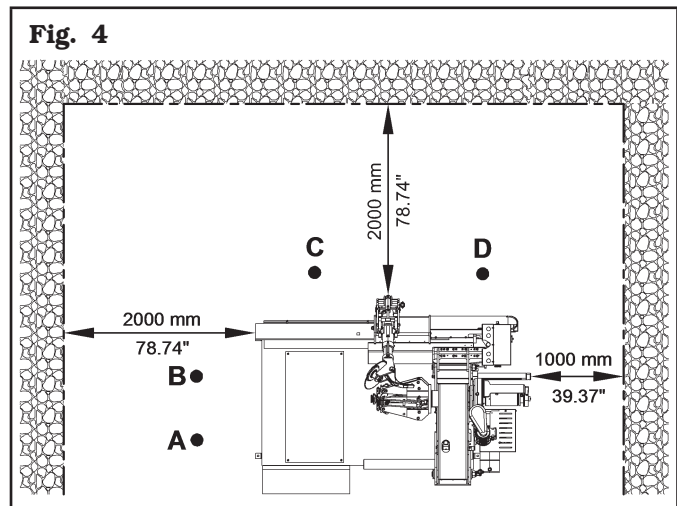



**USE THE MACHINE IN A DRY AND SUFFICIENTLY ILLUMINATED PLACE, CLOSED, PROTECTED FROM ALL WEATHER CONDITIONS AND COMPLYING WITH THE REGULATIONS IN FORCE REGARDING WORK SAFETY.**

The location of the machine requires a usable space as indicated in **Fig. 4**. The positioning of the machine must be according to the distances shown. From the control position the operator is able to observe all the machine and surrounding area.

He must prevent unauthorized personnel or objects that could be dangerous from entering the area. The machine must be secured to a flat floor surface, preferably of cement or tiled. Avoid yielding or irregular surfaces. The base floor must be able to support the loads transmitted during operation. This surface must have a capacity load of at least 500 Kg/m<sup>2</sup> (102 lb/ft<sup>2</sup>). The depth of the solid floor must be sufficient to guarantee that the anchoring bolts hold (excluded from supply).

### **8.3 Lighting**

The machine does not require its own lighting for normal working operations. However, it must be placed in an adequately lit environment.

## **9.0 MACHINE ASSEMBLY**



**EACH MECHANICAL INTERVENTION MUST BE CARRIED OUT BY PROFESSIONALLY QUALIFIED STAFF.**

### **9.1 Anchoring system**

The packed machine is fixed to the support pallet through the holes prearranged on the frame and indicated in the figure below. Such holes can be used also to secure the machine to the ground, using floor anchors (not included in the supply). Before carrying out the definitive fixing, check that all the anchor points are laid down flat and correctly in contact with the fixing surface itself. If not so, insert shimming profiles between the machine and the fixing lower surface, as indicated in **Fig. 5**.

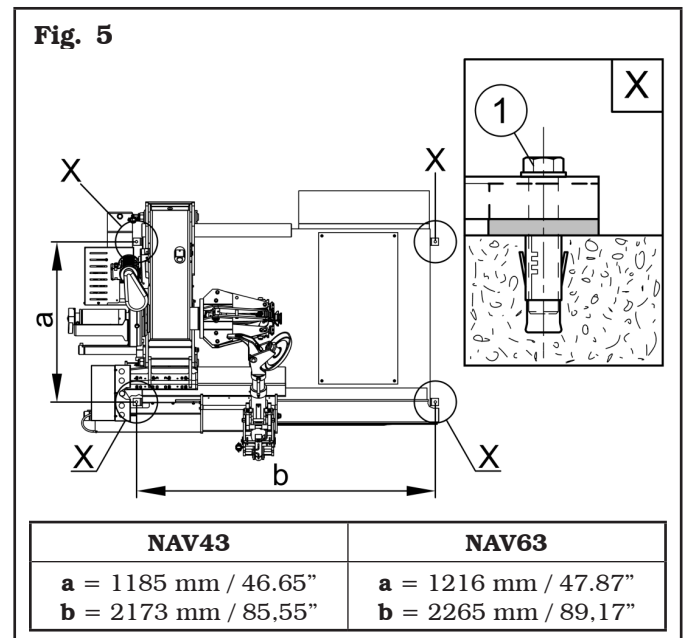

- To fasten the product to the ground, use anchoring plugs (**Fig. 5 ref. 1**) with a threaded shank M12 (UNC 1/2-13) suitable for the floor on which the tyre changer will be fixed and in a number equal to the number of fixing holes arranged on the bottom frame;
- drill holes in the floor, suitable for inserting the chosen anchors, in correspondence with the holes arranged on the bottom frame;
- insert the anchors into the holes made in the floor through the holes on the bottom frame and tighten the threaded elements;
- tighten the anchors on the base frame by applying a torque equal to that indicated by the manufacturer of the anchors.

**10.0 ELECTRICAL CONNECTIONS**

 **EVEN THE TINIEST PROCEDURE OF AN ELECTRICAL NATURE MUST BE CARRIED OUT BY PROFESSIONALLY QUALIFIED STAFF.**

 **BEFORE CONNECTING THE MACHINE MAKE SURE THAT:**

- **POWER LINE SPECIFICATIONS CORRESPOND TO MACHINE REQUIREMENTS AS SHOWN ON THE MACHINE PLATE;**
- **ALL MAIN POWER COMPONENTS ARE IN GOOD CONDITION;**
- **THE ELECTRICAL SYSTEM IS PROPERLY GROUNDED (GROUND WIRE MUST BE THE SAME CROSS-SECTION AREA AS THE LARGEST POWER SUPPLY CABLES OR GREATER);**
- **MAKE SURE THAT THE ELECTRICAL SYSTEM FEATURES A CUTOUT WITH DIFFERENTIAL PROTECTION SET AT 30 MA.**

For any other type of power supply, ask the manufacturer at the time of purchase: a machine functioning under the required voltage conditions will be prepared.

 **FIT A TYPE-APPROVED PLUG TO THE MACHINE CABLE (THE GROUND WIRE IS YELLOW/GREEN AND MUST NEVER BE CONNECTED TO ONE OF THE PHASE LEADS).**

 **MAKE SURE THAT THE ELECTRICAL SYSTEM IS COMPATIBLE WITH THE RATED POWER ABSORPTION SPECIFIED IN THIS MANUAL AND APT TO ENSURE THAT VOLTAGE DROP UNDER FULL LOAD WILL NOT EXCEED 4% OF RATED VOLTAGE (10% UPON START-UP).**

 **IN CASE OF A CHANCE SUPPLY FAILURE, AND/OR BEFORE ANY POWER SUPPLY CONNECTIONS, MOVE THE PEDALS TO THE NEUTRAL POSITION.**

The machine is supplied with a cable. A plug corresponding to the following requirements must be connected to the cable:

Models	Conformity standard	Voltage	Amperage	Poles	Minimum IP rating
3-Ph double speed	IEC 309	230/400V	16 A	3P + Ground	IP 44
Version 230V 50Hz 3Ph		230V			
Version 500V 50Hz 3Ph		500V			
Version 230V 60Hz 3Ph		230V			
Version 220V 60Hz 3Ph		220V			

### 10.1 Manipulator cable connection

Connect the cable through connectors (**Fig. 6 ref. 1**) to the machine socket (**Fig. 6 ref. 2**) and to that of the manipulator (**Fig. 6 ref. 3**), as shown in the drawing.

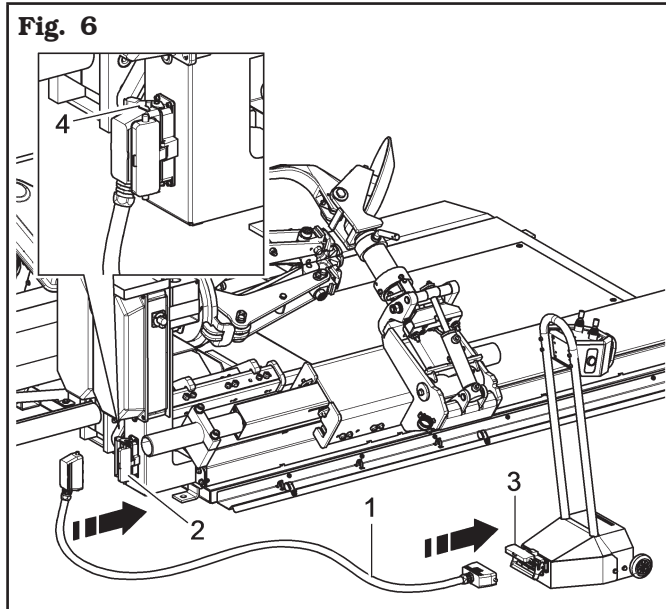

**AFTER CONNECTING THE CABLE, TO PREVENT IT FROM BEING INADVERTENTLY DISCONNECTED DURING OPERATION OF THE MACHINE, MAKE SURE TO LOCK IT USING THE PROVIDED DEVICE (FIG. 6 REF. 4).**

### 10.2 Oil check on oil-pressure power unit



**ANY OIL-PRESSURE INTERVENTION MUST BE CARRIED OUT BY PROFESSIONALLY QUALIFIED STAFF.**



**THE OIL-PRESSURE POWER UNIT IS DELIVERED WITHOUT HYDRAULIC OIL, THEREFORE MAKE SURE THE TANK PROVIDED IS FILLED WITH AN APPROXIMATE AMOUNT OF OIL OF 5 LITRES (1,32 GALLONS), ALWAYS BEING CAREFUL NOT TO SPILL IT OUTSIDE THE TANK.**

**USE HYDRAULIC OIL WITH A VISCOSITY DEGREE APPROPRIATE TO THE AVERAGE TEMPERATURES IN THE INSTALLATION COUNTRY AND IN PARTICULAR:**

- VISCOSITY 32 (OR COUNTRIES WITH ROOM TEMPERATURE FROM 0 °C ÷ +30 °C (+32 °F ÷ +86 °F));
- VISCOSITY 46 (FOR COUNTRIES WITH ROOM TEMPERATURE ABOVE +30 °C degrees (+86 °F)).

### 10.3 Check of motor rotation direction

Once the last electrical connection has been terminated, power the machine with the main switch. Make sure the motor of the hydraulic power unit rotates in the direction indicated by the arrow (**Fig. 7 ref. B**) visible on the electric motor cap. If rotation should occur in the opposite direction, the machine must be immediately stopped and phase inversion must be executed inside the plug connection in order to reset the correct rotation direction.



**FAILURE TO OBSERVE THE ABOVE INSTRUCTIONS WILL IMMEDIATELY INVALIDATE THE WARRANTY.**

### 10.4 Electrical checks



**BEFORE STARTING UP THE TYRE-CHANGER, BE SURE TO BECOME FAMILIAR WITH THE LOCATION AND OPERATION OF ALL CONTROLS AND CHECK THEIR PROPER OPERATION (SEE PAR. "CONTROLS").**



**CARRY OUT A DAILY CHECK OF THE MAINTAINED ACTION CONTROLS CORRECT FUNCTIONING, BEFORE STARTING MACHINE OPERATION.**

Once the plug/socket connection has been made, turn on the machine using the main switch (**Fig. 7 ref. A**).

#### Bluetooth versions only

Then horizontally or vertically move the lever (**Fig. 9 ref. H**): the red LED (**Fig. 9 ref. B**) will turn on. Wait a few seconds for the green LED turning on (**Fig. 9 ref. A**) and then release the lever (**Fig. 9 ref. H**). In the end, the green LED (**Fig. 9 ref. A**) flashes to indicate that the machine is ready for operation.



**WHEN A CONTROL IS OPERATED, THE GREEN LED (FIG. 9 REF. A) LIGHT IS FIXED: IT FLASHES AGAIN WHEN IT IS RELEASED.**

If during the operations the red LED (**Fig. 9 ref. B**) turns on and the green led turns off, charge the control batteries with the provided socket for battery charger, located under the control (**Fig. 9 ref. M**).

#### For all models

The machine is equipped with a device for the interruption of the communication between the control and the electrical cabinet, when more than 6 hours have passed after the last executed control. In this case, just repeat the turning on operations described in the "Electrical checks" chapter.



**ONCE THE ASSEMBLY OPERATIONS HAVE BEEN ENDED, CHECK ALL MACHINE FUNCTIONS.**

Fig. 7

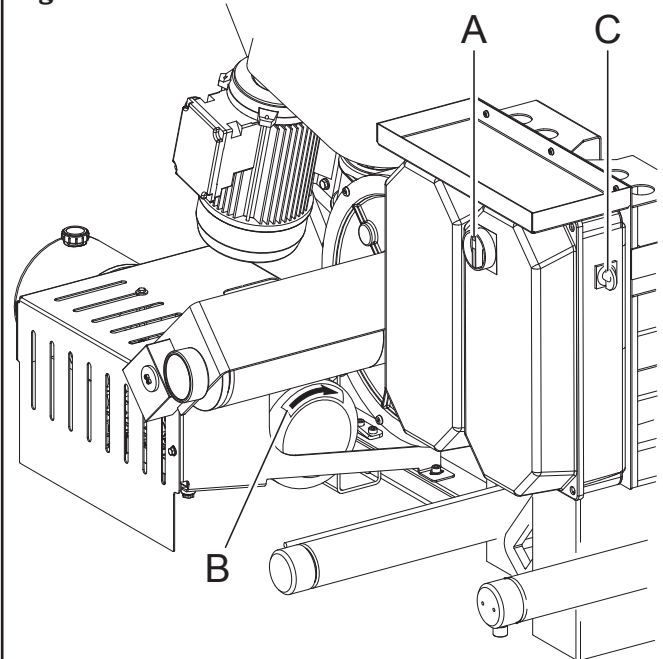

#### KEY

- A - Main switch
- B - Rotation direction of power unit motor
- C - Selector 1-0-2 self-centring chuck speed control

## 11.0 CONTROLS

### 11.1 Control device

The control (handle control) can be moved according to the positioning necessities of the operator.

The operator should place the control in a zone free from obstacles in order to see clearly and completely the operative zone.



**MAKE SURE THERE ARE NO PERSONS OR OBJECTS HIDDEN TO THE OPERATOR VISUAL FIELD BY THE WHEEL SIDE PLAY (ESPECIALLY IN CASE OF WHEELS WITH LARGE DIMENSIONS).**

“Lever **A**” has four maintained action operative positions:

- Lever rightwards or leftwards, operates respectively the chuck holder carriage shifting rightwards or leftwards.

- Lever upwards or downwards: it operates respectively the rising and the lowering of the chuck holding arm.

“Pedal **B**” controls chuck clockwise and counter-clockwise rotation.

“Push button **C**” has a maintained action position, and when pressed it rotates the tools holder head counter-clockwise (from behind the tool).

“Push button **D**” has a maintained action position, and when pressed it rotates the tools holder head clockwise (from behind the tool).

“Push button **E**” has a maintained action position and when pressed, it operates the self-centring chuck opening.

“Push button **F**” has a maintained action position, and when pressed it operates the self-centring chuck closing.

“Push button **G**” has a maintained action position: when it is pressed and lever “**A**” or “**H**” is laterally shifted at the same time, it doubles the movement speed of the self-centring carriage and of the tool holder carriage respectively.

“Lever **H**” has four maintained action positions:

- Lever rightwards or leftwards, operates respectively the tool holder carriage shifting rightwards or leftwards.

- Lever upwards or downwards: it respectively lowers or lifts the tool holder arm.



**THE HANDLE MUST NOT BE PLACED WHERE WATER STAGNATES.**

**Fig. 8**

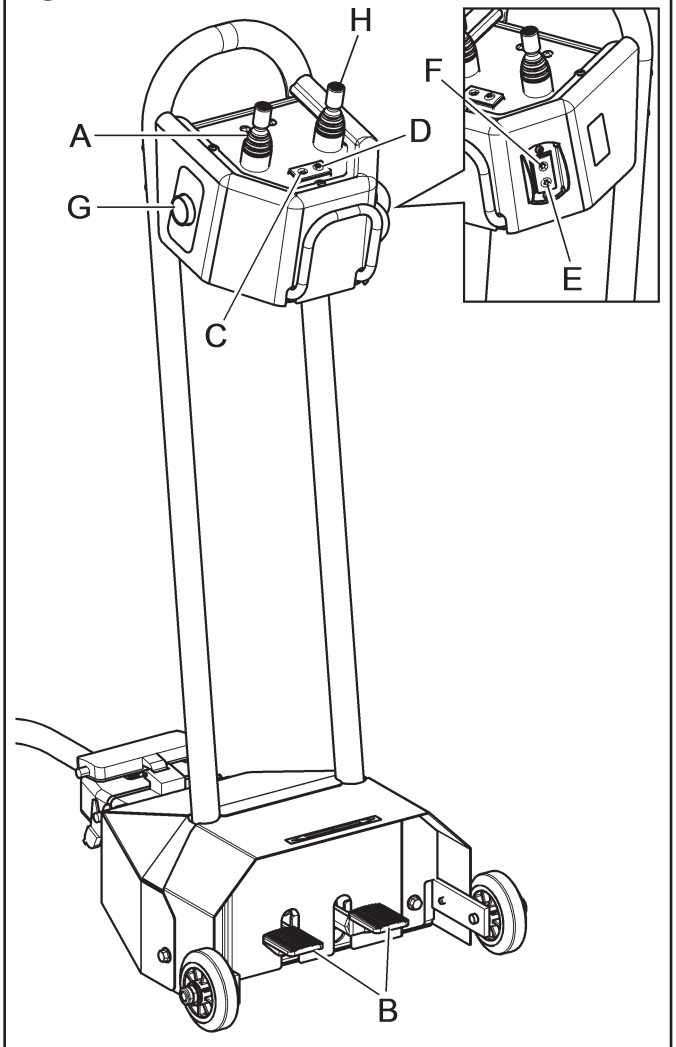

**11.2 Control device with bluetooth transmission (Bluetooth versions only)**

The control (handle control) can be moved according to the positioning necessities of the operator. The operator should place the control in a zone free from obstacles in order to see clearly and completely the operative zone.



**MAKE SURE THERE ARE NO PERSONS OR OBJECTS HIDDEN TO THE OPERATOR VISUAL FIELD BY THE WHEEL SIDE PLAY (ESPECIALLY IN CASE OF WHEELS WITH LARGE DIMENSIONS).**

The flashing green LED "A", indicates the machine stand-by position. When any control is operated, the machine is started and it is ready for operation. During functioning, the LED "A" is turned on with a fixed light. The red turned on LED "B" and the green turned off LED "A" indicate that the manipulator batteries are exhausted: in order to carry on the functioning, the batteries must be charged.



**IN ORDER TO ACTIVATE THE COMMUNICATION BETWEEN HANDLE CONTROL AND MACHINE, ON MACHINE SWITCHING AND AFTER EACH POSITIONING IN STAND-BY MODE, IT'S NECESSARY TO OPERATE ANY JOYSTICK (LEVER "H" OR LEVER "I") FOR 5 SECONDS AT LEAST.**

"Push button C" has a maintained action position, and when pressed it rotates the tools holder head counter-clockwise (from behind the tool).

"Push button D" has a maintained action position, and when pressed it rotates the tools holder head clockwise (from behind the tool).

"Push button E" has a maintained action position and when pressed, it operates the self-centring chuck opening.

"Push button F" has a maintained action position, and when pressed it operates the self-centring chuck closing.

"Push button G" has a maintained action position: when it is pressed and lever "I" or "H" is laterally shifted at the same time, it doubles the movement speed of the self-centring carriage and of the tool holder carriage respectively.

"Lever H" has four maintained action positions:

- Lever rightwards or leftwards, operates respectively the tool holder carriage shifting rightwards or leftwards.
- Lever upwards or downwards: it respectively lowers or lifts the tool holder arm.

"Lever I" has four maintained action positions:

- Lever rightwards or leftwards, operates respectively the chuck holder carriage shifting rightwards or leftwards.

- Lever upwards or downwards: it operates respectively the rising and the lowering of the chuck holding arm. "Pedal L" starts clockwise and anti-clockwise rotation of the chuck.

When any control is operated, the machine is started again, ready for operation: LED "A" flashes.



**THE HANDLE MUST NOT BE PLACED WHERE WATER STAGNATES.**

**Fig. 9**

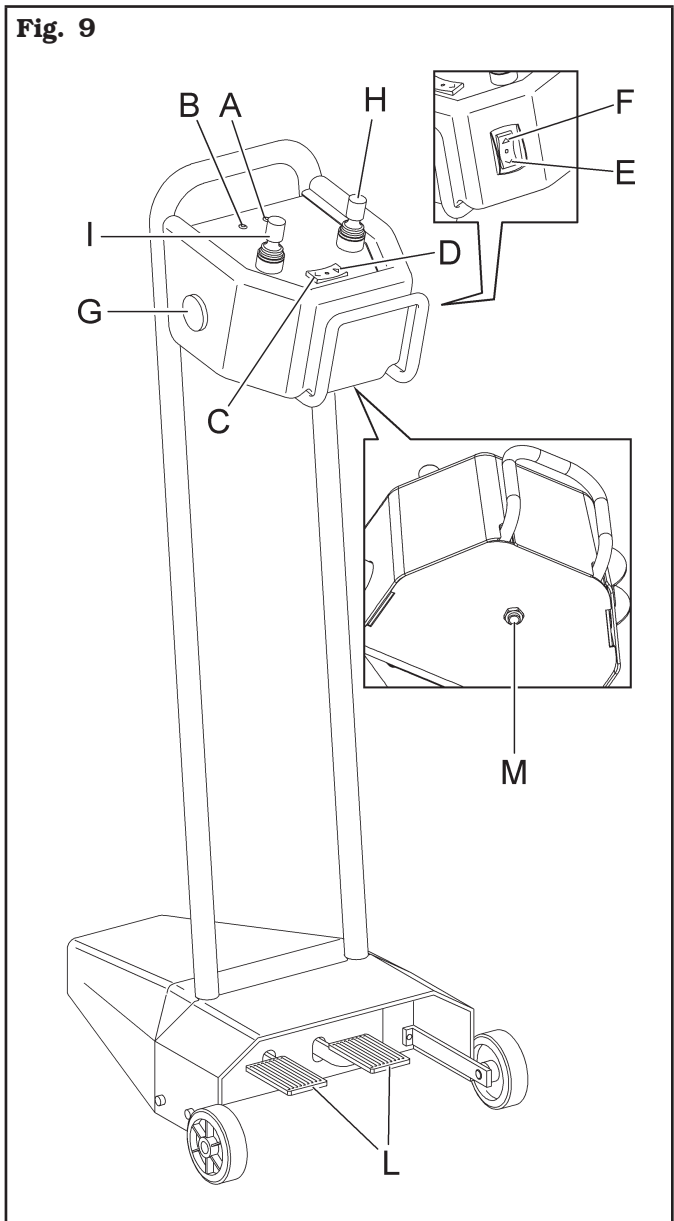



**11.3 Handle control in air (aerial handle control versions only)**

The control (handle control) can be moved according to the positioning necessities of the operator.

Lever handling (**Fig. 10 ref. 3**) in **A** position, with maintained action, lifts the tools holder arm.

Lever handling (**Fig. 10 ref. 1**) in **B** position, with maintained action, controls the self-centring carriage arm rising.

Lever handling (**Fig. 10 ref. 1**) in **C** position, with maintained action, controls the self-centring carriage arm descent.

Lever handling (**Fig. 10 ref. 1**) in **D** position, with maintained action, controls the self-centring carriage right shifting.

Lever handling (**Fig. 10 ref. 3**) in **E** position, to "hands-on" operating position, controls the tools holder carriage right shifting.

Lever handling (**Fig. 10 ref. 1**) in **F** position, with maintained action, controls the self-centring carriage left shifting.

Lever handling (**Fig. 10 ref. 3**) in **G** position, with maintained action, controls the tools holder carriage left shifting.

Lever handling (**Fig. 10 ref. 3**) in **H** position, with maintained action, lowers the tools holder arm.

"**Push button P**" has a maintained action position, and when pushed in combination with the horizontal movement of levers **3** and/or **1**, it doubles tool-holder or self-centring carriage shifting speed. Pressing push button "**P**" in combination with the vertical movement of lever "**1**" it doubles the rise or descent speed of the self-centring carriage.

"**Lever 2**" has two maintained action positions: turned to right (**Ref. O**) or to left (**Ref. Q**), it respectively controls the clockwise and counterclockwise rotation of the self-centring chuck.

"**Push button I**" has a maintained action position, and when pressed it opens the self-centring chuck.

"**Push button L**" has a maintained action position, and when pressed it closes the self-centring chuck.

"**Push button M**" has a maintained action position, and when pressed, it operates the counterclockwise rotation of the tools holder head (from behind the tool).

"**Push button N**" has a maintained action position, and when pressed, it operates the clockwise rotation of the tools holder head (from behind the tool).

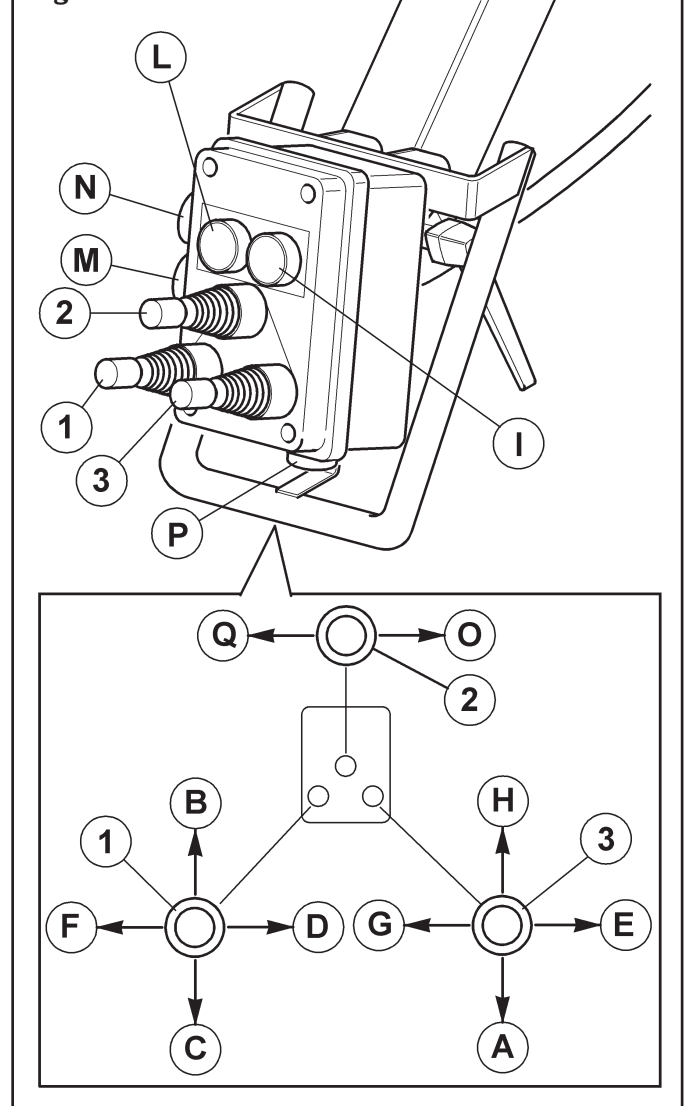
**Fig. 10**

## 12.0 USING THE MACHINE

### 12.1 Precaution measures during tyre removal and fitting



Before fitting a tyre, observe the following safety rules:

- always use clean, dry and in good condition rims and tyres; in particular, if necessary, clean the rims after all the old balancing weights (as well as the adhesive weights on the inner side) have been removed, and make sure that:
  - neither the bead nor the tread of the tyre are damaged;
  - the rim does not produce dents and/or deformation (especially for alloy rims, dents can cause internal micro-fractures, that pass unobserved at visual inspection, and can compromise the solidity of the rim and constitute danger even during inflation);
- adequately lubricate the contact surface of rim and the tyre beads, using specific tyre lubricants only;
- replace the inner pipe valve with a new valve, if the tyre pipe has a metal valve, replace the grommet;
- always make sure that tyre and rim sizes are correct for their coupling; on the contrary, never fit a tyre unless you are sure it is of the right size (the rated size of rim and tyre is usually printed directly on them);
- do not use compressed air or water jets to clean the wheels on the machine.

### 12.2 Preliminary operations

In view of the tyre changer structure and of its intended use, the operator must work with wheels with large diameter (up to 2360 mm / 93" on NAV43 model and up to 2700 mm / 106" on NAV63 model) and with remarkable weight (up to 2300 kg / 5070 lbs on NAV43 model and up to 2600 kg / 5732 lbs on NAV63 model). The utmost care while moving the wheels is recommended: make use of other operators, properly trained and with suitable clothes.



**THROUGHOUT TYRE MOUNTING AND DEMOUNTING OPERATIONS, THE SELF-CENTRING CHUCK ROTATION SPEED CAN BE DOUBLED BY ROTATING THE SELECTOR (FIG. 7 REF. C). LOW SPEED IS RECOMMENDED FOR WHEELS WITH GREAT DIAMETER AND WEIGHT. THE CAREFUL LUBRICATION OF THE TYRE BEADS IS ALSO RECOMMENDED, IN ORDER TO PROTECT THEM FROM POSSIBLE DAMAGES AND TO FACILITATE MOUNTING AND DEMOUNTING OPERATIONS.**

### 12.3 Preparing the wheel

- Remove the wheel balancing weights from both sides of the wheel.



**REMOVE THE VALVE STEM AND ALLOW THE TYRE TO COMPLETELY DEFLATE.**

- Establish from which side the tyre should be demounted, checking the position of the groove.
- Find the rim locking type.

**12.4 Wheel clamping**

**FOR WHAT CONCERNS THE DIMENSIONS AND WEIGHT OF THE WHEEL TO BE LOCKED, MAKE USE OF A SECOND OPERATOR WHO MUST HOLD THE WHEEL INTO VERTICAL POSITION, IN ORDER TO ENSURE SAFE OPERATIVE CONDITIONS.**



**WHEN HANDLING WHEELS WEIGHING MORE THAN 500 KG (1102 LBS) A FORK-LIFT TRUCK OR A CRANE SHOULD BE USED.**



**MAKE SURE THAT RIM CLAMPING IS DONE PROPERLY AND THAT THE GRIP IS SAFE, TO PREVENT THE WHEEL FROM FALLING DURING MOUNTING OR REMOVAL OPERATIONS.**

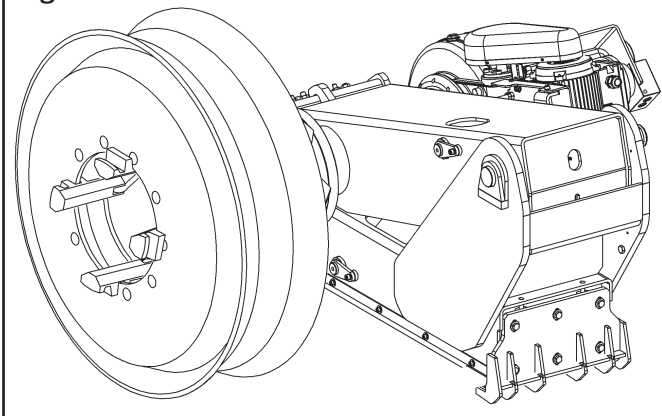

**DO NOT CHANGE THE SET OPERATING PRESSURE VALUE BY MEANS OF THE MAXIMUM PRESSURE VALVES. THE MANUFACTURER SHALL NOT BE RESPONSIBLE FOR INJURY OR DAMAGE ARISING FROM UNAUTHORIZED CHANGES.**

**Fig. 11**

Clamping on the central hole

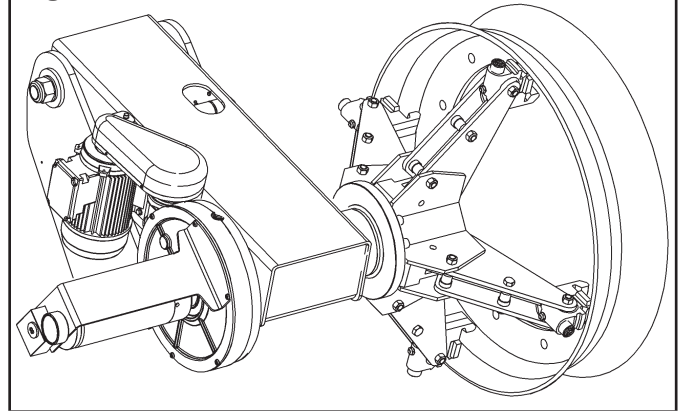
**Fig. 12**

Clamping on bead seat



**OPENING/CLOSING MOVEMENT OF THE SELF-CENTRING CHUCK CAN GENERATE DANGER OF SQUASHING, CUTTING, COMPRESSION. DURING WHEEL LOCKING/UNLOCKING PHASE, AVOID THAT PARTS OF HUMAN BODY COME INTO CONTACT WITH MOVING PARTS OF THE MACHINE.**

All wheels must be clamped from the inside.  
**Clamping on the central flange is always safest.**



**FOR WHEELS WITH GROOVED RIMS SECURE THE WHEEL SO THAT THE GROOVE IS FACING OUTWARDS COMPARED TO THE CHUCK.**

If it is not possible to clamp the rim in the hole of the disc, clamp on the bead seat close to the disc.



**TO SECURE WHEELS WITH ALLOY RIMS ADDITIONAL PROTECTIVE CLAMPS ARE AVAILABLE. THEY ALLOW YOU TO WORK ON THE RIMS WITHOUT DAMAGING THEM. THE PROTECTIVE CLAMPS ARE FITTED ONTO THE CHUCK'S NORMAL CLAMPS BY MEANS OF A BAYONET CONNECTION.**

To clamp the wheel proceed as follows:

- Move the tool holder arm (**Fig. 15 ref. 1**) to “out of work” position, manually or with the help of the provided controls, according to the model of tyre changing machine which is being used;
- Place the wheel vertical on the machine table;
- Translate the chuck carriage towards the tyre until the self-centring arms are inserted inside the rim;
- Adjust the opening of the self-centring chuck through the “opening/closing” control (**Fig. 8 ref. E/F**) according to the type of rim to be locked;
- The lever (**Fig. 8 ref. A**) to position the coaxial chuck with the wheel centre, in order to make clamp edges skim the wheel edge;
- Operate the control (**Fig. 8 ref. E**) until the wheel is completely clamped;
- Make sure the rim is always correctly locked and centred, and the wheel is lifted from the machine platform, in order to prevent the rim from slipping in the following operations.



**KEEP ON OPERATING RIM CLAMPING CONTROL, UNTIL REACHING THE MAX. OPERATING PRESSURE (160÷180 BAR / 2320÷2610 PSI), WHICH CAN BE CHECKED THROUGH THE PREARRANGED PRESSURE GAUGE.**



**THROUGHOUT TYRE MOUNTING AND DEMOUNTING OPERATIONS, THE SELF-CENTRING CHUCK ROTATION SPEED CAN BE DOUBLED BY ROTATING THE SELECTOR (FIG. 7 REF. C). LOW SPEED IS RECOMMENDED FOR WHEELS WITH GREAT DIAMETER AND WEIGHT. THE CAREFUL LUBRICATION OF THE TYRE BEADS IS ALSO RECOMMENDED, IN ORDER TO PROTECT THEM FROM POSSIBLE DAMAGES AND TO FACILITATE MOUNTING AND DEMOUNTING OPERATIONS.**

**Fig. 13**

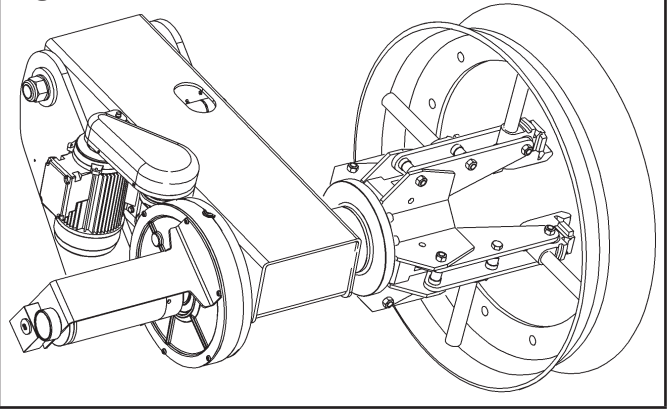

Locking with extensions

Whenever the rim exceeds the 42” in the locking point, use the appropriate extensions supplied with the tyre-changer. To avoid damages or scratches on light alloy rims, the special clamps supplied with the tyre changer as an optional should be used.



**AFTER COMPLETION OF TYRE MOUNT/DEMOUNT OPERATIONS DO NOT LEAVE THE WHEEL CLAMPED ON THE SELF-CENTRING CHUCK AND NEVER LEAVE IT UNATTENDED ANYWAY.**



**THROUGHOUT TYRE MOUNTING AND DEMOUNTING OPERATIONS, THE SELF-CENTRING CHUCK ROTATION SPEED CAN BE DOUBLED BY ROTATING THE SELECTOR (FIG. 7 REF. C). LOW SPEED IS RECOMMENDED FOR WHEELS WITH GREAT DIAMETER AND WEIGHT. THE CAREFUL LUBRICATION OF THE TYRE BEADS IS ALSO RECOMMENDED, IN ORDER TO PROTECT THEM FROM POSSIBLE DAMAGES AND TO FACILITATE MOUNTING AND DEMOUNTING OPERATIONS.**

### **12.5 Functioning of tools holder arm**

During the working phases, the tools holder arm can maintain two firm positions, that is:

- 1) "Working" position;
- 2) "Out of work" position.

In "working" position (**Fig. 14 ref. 1**) the tools holder arm is lowered towards the chuck and from this position it executes the various tyre bead breaking, demounting and mounting operations.

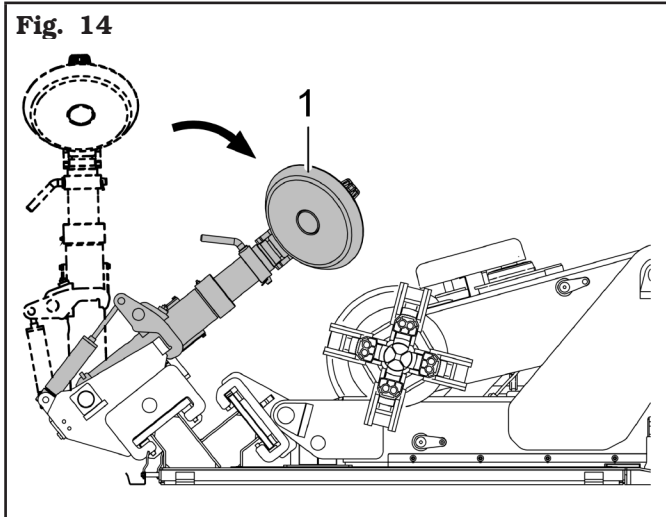

In "out of work" position (**Fig. 15 ref. 1**): the tools holder arm is in vertical position and has to be brought in this position every time it is not in use and in order to be shifted from one tyre side to another, during the different working phases.

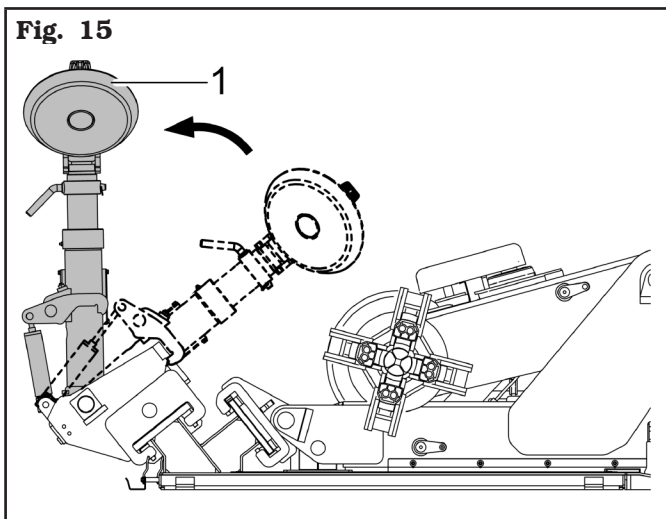

The tools holder arm moves from "out of work" position to "working position through hydraulic cylinder.



**IN WORK POSITION, THE SAFETY JACKS (FIG. 1 REF. 8) MUST BE HOOKED TO THE TOOL CARRIAGE (FIG. 1 REF. 13).**

To shift from "work" position to "off-work" position, the tools holder arm moves by the handle control that activates the cylinder (**Fig. 1 ref. 21**).

The tools holder arm moves from "out of work" position to "working position through hydraulic cylinder.

#### **12.5.1 Tools rotation**

Tools holder head 180° rotation is automatic, and it takes place through handle control operation (**Fig. 8 ref. C and D**).

#### **12.5.2 Tools unit extraction/insertion**

The tools holder head has two working positions.



**THE FOLLOWING OPERATIONS MUST BE CARRIED OUT WITH THE TOOLS HEAD IN "OFF-WORK" POSITION.**

Remove the safety split pin (**Fig. 16 ref. 1**) and manually extract the lever (**Fig. 16 ref. 2**) to change from one position to another. Manually lift or lower the tools holder head until the locking holes match (**Fig. 16 ref. 3**).



**WHEN THE TOOLS HOLDER HEAD IS LOWERED, MOVE THE HEAD ITSELF DOWNWARDS WITH THE FREE HAND.**

When the new position has been reached, insert the lever again (**Fig. 16 ref. 2**) in the provided hole and assemble the safety split pin (**Fig. 16 ref. 1**) again.

**Fig. 16**

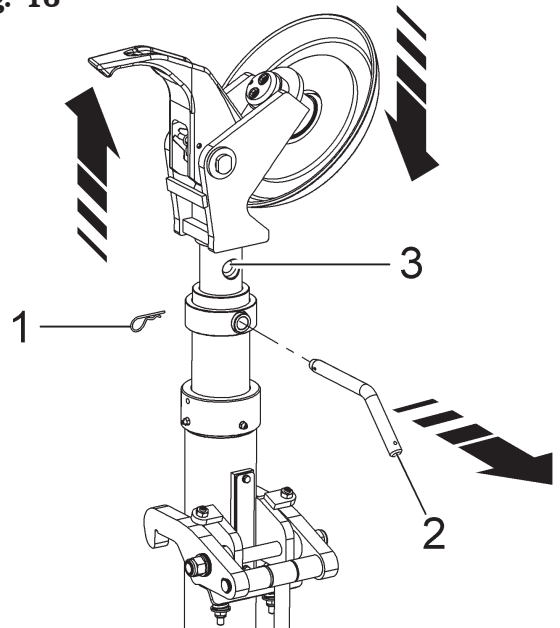

## 12.6 Tubeless tyres

### 12.6.1 Bead breaking



**NEVER PLACE ANY PART OF YOUR BODY BETWEEN THE TOOLS UNIT AND THE TYRE.**



**THROUGHOUT TYRE MOUNTING/DEMOUNTING OPERATIONS, CHECK THAT THE SELF-CENTRING CHUCK CLAMPING PRESSURE IS CLOSE TO THE MAX. OPERATING VALUE (160 - 180 BAR / 2320 - 2610 PSI).**

- A. Lock the wheel on the chuck as described in the previous paragraph.
- B. Remove all balancing weights from the rim. Extract the valve and let air out of tyre.
- C. Move to work position C (Fig. 4).
- D. Lower tools holder arm into work position (hooked safety jack) (Fig. 14).



**ALWAYS MAKE SURE THAT THE ARM IS CORRECTLY HOOKED TO CARRIAGE.**

- E. Place as shown in Fig. 17 the beading disc (Fig. 17 ref. 1) by means of the relevant handle control; the outer profile of the rim (Fig. 17 ref. 2) must almost touch the bead breaking disc.

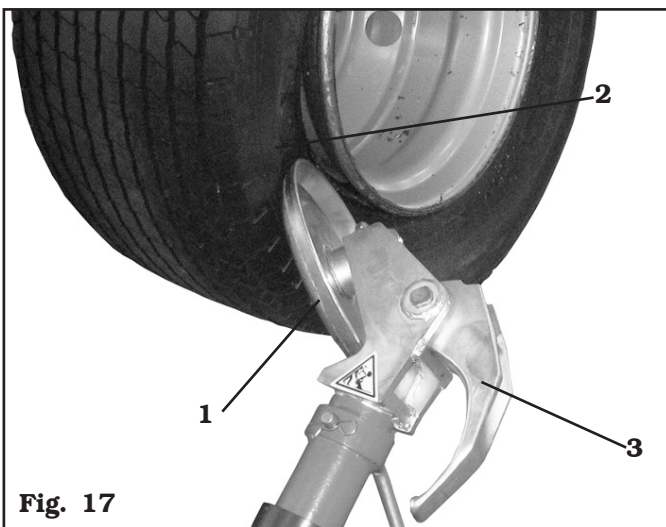

Fig. 17



**THE BEAD BREAKING DISC MUST NOT EXERT PRESSURE ON THE RIM BUT ON THE TYRE BEAD.**

- F. Turn the chuck counterclockwise and, at the same time, gradually move the tool carrier inwards to bead the tyre. Keep turning the chuck while generously lubricating the tyre rim and bead with a suitable lubricant. To avoid risks, lubricate the beads by turning clockwise if you are working on the outer side or counterclockwise if you are working on the inner side. The more the wheel adheres to the rim, the slower should the beading disc advance.



**USE ONLY TYRE LUBRICANTS. SUITABLE LUBRICANTS CONTAIN NO WATER, HYDROCARBONS, OR SILICONE.**

- G. Once external beading has been carried out, unhook and lift the tool holder arm placing it in "off-work" position (Fig. 15 ref. 1); use the handle control to position the tool holder arm on the inner side of the wheel, then place it in "work position" (Fig. 14 ref. 1) and secure it with the special safety jack.



**PAY ATTENTION WHEN REPOSITIONING THE TOOLS HOLDER ARM TO AVOID CRUSHING HANDS.**

- H. Carry out the tools holder head 180° rotation according to the descriptions of the relevant paragraph, so that the beading disc (Fig. 18 ref. 1) is placed against the rim edge (Fig. 18 ref. 2).
- I. Move to work position D (Fig. 4) and repeat the operations described in points E, F until the tyre has been completely beaded.

Throughout beading operations it is advisable to bend the hook tool (Fig. 17 and Fig. 18 ref. 3) back to itself to avoid obstacles during the operating phases.

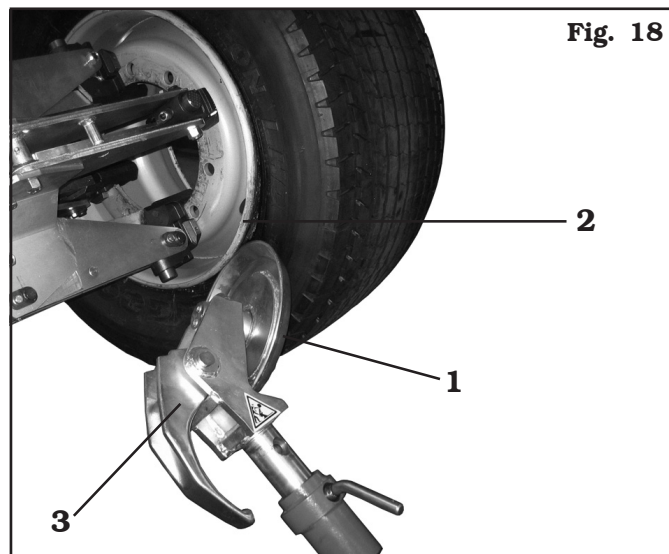

Fig. 18

### 12.6.2 Demounting



**THROUGHOUT TYRE MOUNTING/DEMOUNTING OPERATIONS, CHECK THAT THE SELF-CENTRING CHUCK CLAMPING PRESSURE IS CLOSE TO THE MAX. OPERATING VALUE (160 - 180 BAR / 2320 - 2610 PSI).**

**Tubeless tyres can be removed in two ways:**

**A.** If the wheel does not present particular problems, continuing beading operation will completely dislodge the beads from the rim. The inner bead, pushed by the disc, presses against the outer one till it has been completely removed (see **Fig. 19**).

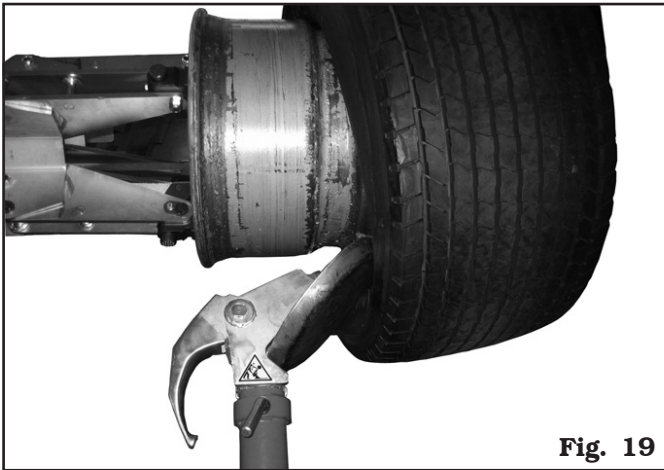

**Fig. 19**

**B.** If the wheel is especially hard, it is not possible to carry out the procedure described in point **A**. A different procedure will be necessary: use the hook tool and follow this sequence of operations:

- Move to work position **C** (**Fig. 4**).
- Position the tool holder arm on the outer side of the wheel and bring forward the hook tool, inserting it between rim and bead up to it is secured to the bead itself (see **Fig. 20**).

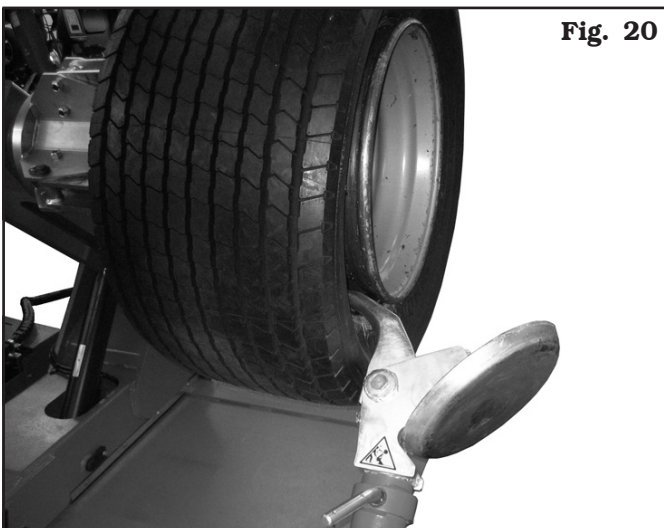

**Fig. 20**

- Move the rim away from the tool by about 4-5 cm (1.6" - 2") to avoid possible unhooking of the bead from the same tool.
- Move to work position **A** (**Fig. 4**).
- Translate the tool outwards (**Fig. 21 ref. 2**) to allow easy insertion of lever (**Fig. 21 ref. 1**) between the rim and the bead; insert lever (**Fig. 21 ref. 1**) between the rim and the bead on the right-hand side of the tool (**Fig. 21 ref. 2**).

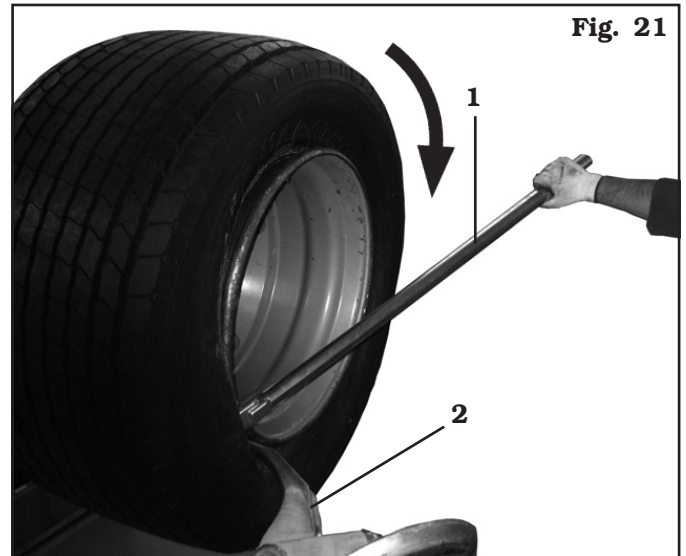

**Fig. 21**

- Keeping the lever pressed, lower the wheel until the edge of the rim is 5 mm distant from the hook tool.
- Turn the wheel clockwise keeping lever pressed (**Fig. 21 ref. 1**) until the bead has gone completely out.
- Once the external bead has been removed, move tool holder arm away from the wheel, unhook it and lift it bringing it in "off-work" position (**Fig. 15 ref. 1**); use the handle control to position the tool holder arm on the inner side of the wheel then place it in work position again (**Fig. 14 ref. 1**) and secure with the safety hook provided.



**PAY ATTENTION WHEN REPOSITIONING THE TOOLS HOLDER ARM TO AVOID CRUSHING HANDS.**



**ALWAYS MAKE SURE THAT THE ARM IS CORRECTLY HOOKED TO CARRIAGE.**

- Move to work position **D** (Fig. 4).
- Carry out the tool holder head 180° rotation in order to insert the hook tool (Fig. 22 ref. 1) between the rim edge and the tyre bead.

Fig. 22



- Move the rim away from the tool by about 4-5 cm (1.6"- 2") to avoid possible unhooking of the bead from the same tool.
- Move to work position **B** (Fig. 4).
- Translate the hook tool outwards to allow easy insertion of the lever between the rim and the bead on the tool left. Keeping the lever pressed, lower the wheel until the edge of the rim is 5 mm (0.2") distant from the hook tool then turn the chuck counterclockwise until the tyre has been completely removed.



**THE REMOVAL OF THE BEADS FROM THE RIM CAUSES THE TYRE TO FALL. ALWAYS MAKE SURE THAT NO ONE IS STANDING BY ACCIDENT IN THE WORK AREA.**

### 12.6.3 Mounting



**WHEN DEMOUNTING VERY HEAVY TYRES, IT IS IMPORTANT TO MOVE THE WHEEL AS CLOSE AS POSSIBLE TO THE BASE BEFORE COMPLETING THE OPERATION.**



**THROUGHOUT TYRE MOUNTING/DEMOUNTING OPERATIONS, CHECK THAT THE SELF-CENTRING CHUCK CLAMPING PRESSURE IS CLOSE TO THE MAX. OPERATING VALUE (160 - 180 BAR / 2320 - 2610 PSI).**

Tubeless tyre fitting is normally done with the disc tool; if the wheel is especially hard to fit, use the hook tool.

#### With bead breaking disc

Proceed as follows:

- Secure the rim to the chuck according to the procedure described in paragraph "WHEEL CLAMPING".
- Adequately lubricate tyre beads and rim bead seats with a suitable lubricant using the supplied brush.



**USE ONLY TYRE LUBRICANTS. SUITABLE LUBRICANTS CONTAIN NO WATER, HYDROCARBONS, OR SILICONE.**

- Mount clamp (Fig. 23 ref. 1) on the external edge of the rim in the highest point as shown in Fig. 23.

Fig. 23

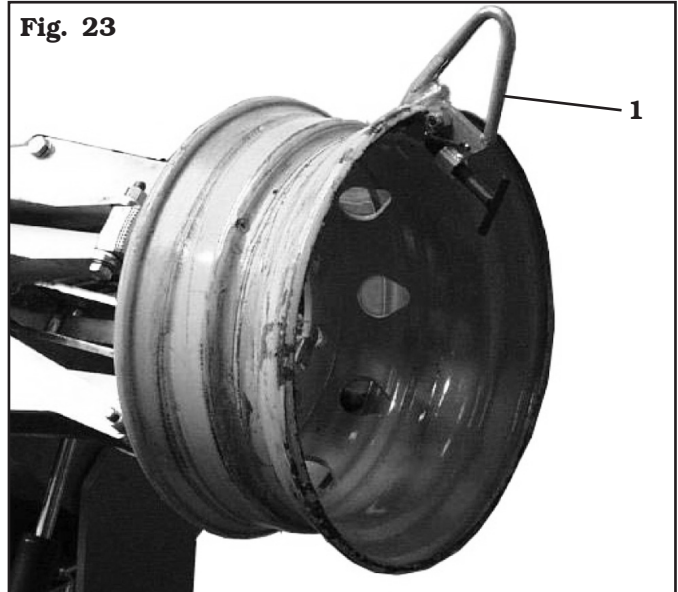





**THE CLAMP MUST BE TIGHTLY SECURED TO THE EDGE OF THE RIM.**

- Move to work position **B** (Fig. 4).
- Lower the chuck arm completely. Roll the tyre on the platform and hook it to clamp (Fig. 24 ref. 1).
- Lift the chuck arm with the tyre hooked and turn it counterclockwise about 15-20 cm (5.9"- 7.9"); the tyre will position itself sideways in relation to the rim (see Fig. 24).

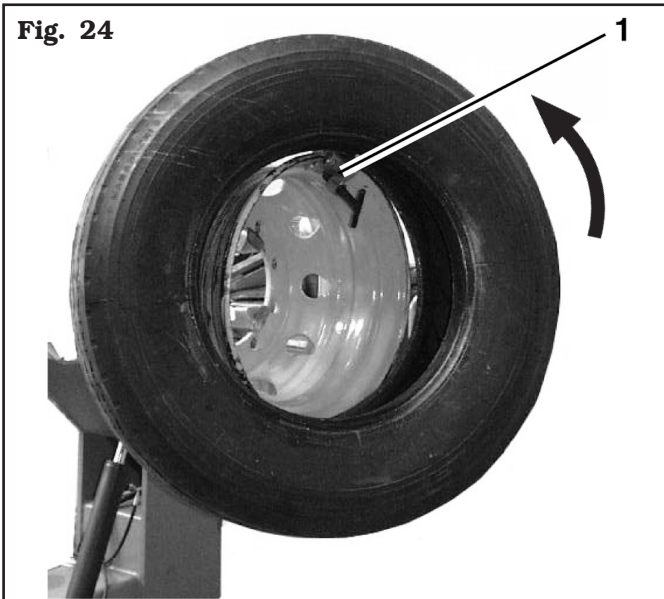
**Fig. 24**

- Move to work position **C** (Fig. 4).
- Position bead breaking disc (Fig. 25 ref. 2) so that it is at approximately 1,5 cm (0.6") from the edge of the rim. The fitting clamp (Fig. 25 ref. 1) is at 11 o'clock. Turn the chuck until the clamp reaches the lowest point ("6 o'clock").

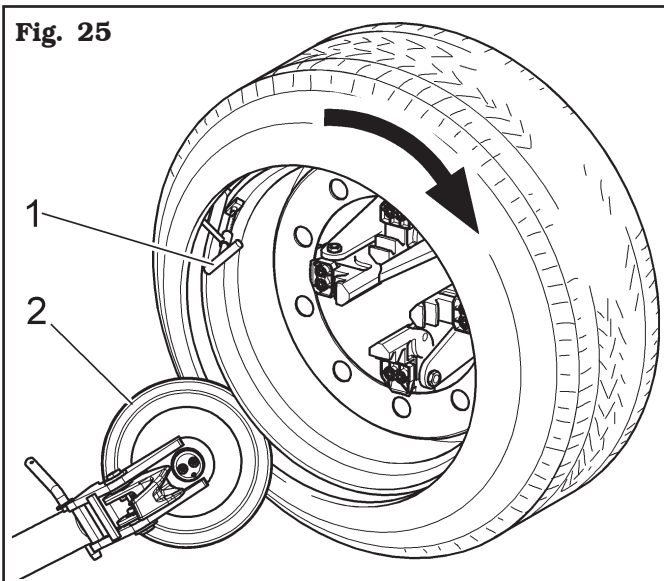
**Fig. 25**

- Move the bead breaking disc away from the wheel.
- Remove the clamp and fit it in the same position ("6 o'clock") outside the second bead.
- Turn the chuck 90° clockwise up to the clamp is at "9 o'clock".
- Move the beading disc forward until it is inside the edge of the rim by about 1-2 cm (0.4"- 0.8") , making sure it is approximately 5 mm (0.2") from rim edge. Start clockwise rotation making sure that, after a 90° turn, the second bead begins sliding in the rim groove.
- Once insertion is completed, move the tool away from the wheel, turn it over into "out of work" position and remove the clamp.
- Lower the chuck until the wheel rests on the foot-board.
- Move to work position **A** (Fig. 4).
- Close the chuck clamps completely, making sure the wheel is held up to avoid dropping.



**MAKE SURE THAT THE WHEEL'S HOLD IS SECURE TO AVOID IT FALLING DURING REMOVAL. FOR HEAVY AND/OR VERY LARGE WHEELS USE AN ADEQUATE LIFTING DEVICE.**

- Translate the platform to release the wheel from the chuck. With especially soft tyres, simultaneously insert both beads on the clamp so that bead insertion in the tyre is done only once; this single operation is ideal for saving time.

**With hook tool**

Proceed as follows:

- Secure the rim to the chuck according to the procedure described in paragraph "WHEEL CLAMPING".
- Adequately lubricate tyre beads and rim bead seats with a suitable lubricant using the supplied brush.



**USE ONLY TYRE LUBRICANTS. SUITABLE LUBRICANTS CONTAIN NO WATER, HYDROCARBONS, OR SILICONE.**

- Mount the clamp (Fig. 23 ref. 1) on the external edge of the rim in the highest point.



**THE CLAMP MUST BE TIGHTLY SECURED TO THE EDGE OF THE RIM.**

- Move to work position **B (Fig. 4)**.
- Lower the chuck arm completely. Roll the tyre on the platform and hook it to clamp (**Fig. 24 ref. 1**).
- Lift the chuck arm with the tyre hooked and turn it counterclockwise about 15-20 cm (5.9"- 7.9"); the tyre will position itself sideways in relation to the rim (see **Fig. 24**).
- Place the tool holder arm in "out of work" position (**Fig. 15 ref. 1**); translate it to the inner side of the tyre and hook it again into "working" position (**Fig. 14 ref. 1**).
- Carry out the tools head 180° rotation up to the hook tool is moved onto the tyre side (see **Fig. 26**).

Fig. 26



- Move to work position **D (Fig. 4)**.
- Move the tool forward until the reference notch matches the external edge of the rim coincide at about 5 mm (0.2") from the rim itself.
- Move to work position **C (Fig. 4)**.
- From the external side of the wheel, check the exact position of the tool and, if necessary, correct it. Then, turn the chuck clockwise up to the clamp reaches the lowest point ("6 o'clock"). The first bead should now be inserted in the rim.
- Remove clamp.
- Move to work position **D (Fig. 4)**.
- Extract the tool from the tyre.
- Place the tool holder arm in "out of work" position (**Fig. 15 ref. 1**); translate it to the outer side of the tyre and hook it again into "working" position (**Fig. 14 ref. 1**).
- Carry out the tool head 180° rotation until the hook tool is moved onto the tyre side (see **Fig. 20**).

- Mount clamp in the lowest point ("6 o'clock") outside the second bead.
- Move to work position **C (Fig. 4)**.
- Turn the chuck about 90° clockwise up to clamp is at "9 o'clock".
- Move the tool forward until the axis of the reference notch matches that of the external edge of the rim at about 5 mm from the rim itself (**Fig. 20**). Begin clockwise rotation making sure that, after a 90° turn, the second bead begins to slide in the rim groove. Turn the chuck until the clamp reaches the lowest point ("6 o'clock"). The second bead should now be inserted in the rim.
- Move the tool away from the wheel, turn it over into "out of work" position and remove the clamp.
- Lower the chuck until the wheel rests on the foot-board.
- Move to work position **A (Fig. 4)**.
- Close the chuck clamps completely, making sure the wheel is held up to avoid dropping.



**MAKE SURE THAT THE WHEEL'S HOLD IS SECURE TO AVOID IT FALLING DURING REMOVAL. FOR HEAVY AND/OR VERY LARGE WHEELS USE AN ADEQUATE LIFTING DEVICE.**

## 12.7 Tyres with inner pipe

### 12.7.1 Bead breaking



**REMOVE THE LOCK NUT OF THE INNER PIPE VALVE TO ALLOW ITS EXTRACTION DURING TYRE REMOVAL PHASES; REMOVE THE NUT WHEN DEFLATING THE TYRE.**

The beading procedure is the same one described for tubeless tyres.



**WHEN BEADING WHEELS WITH INNER PIPES, INTERRUPT THE FORWARD MOVEMENT OF THE BEAD BREAKING DISC AS SOON AS THE BEADS HAVE BEEN DISLODGED TO AVOID DAMAGE TO THE INNER PIPE OR TO THE VALVE.**

### 12.7.2 Demounting



**THROUGHOUT TYRE MOUNTING/DEMOUNTING OPERATIONS, CHECK THAT THE SELF-CENTRING CHUCK CLAMPING PRESSURE IS CLOSE TO THE MAX. OPERATING VALUE (160 - 180 BAR / 2320 - 2610 PSI).**

- Tilt up tool holder arm, unhook it and lift it placing it in “off-work” position (**Fig. 15 ref. 1**); use the handle control to position the tool holder arm on the outer side of the wheel then place it in work position (**Fig. 14 ref. 1**) and secure with the safety hook provided (**Fig. 1 ref. 8**).



**PAY ATTENTION WHEN REPOSITIONING THE TOOLS HOLDER ARM TO AVOID CRUSHING HANDS.**



**ALWAYS MAKE SURE THAT THE ARM IS CORRECTLY HOOKED TO CARRIAGE.**

- Carry out the tools holder head 180° rotation, according to the descriptions in the relevant paragraph, in order to insert the hook between the rim edge and the tyre bead; the operation must be carried out during chuck rotation.
- Move the rim away from the tool by about 4-5 cm (1.6”- 2”) to avoid possible unhooking of the bead from the same tool.
- Translate the hook tool outwards until the reference notch matches the external edge of the rim.
- Move to work position **A** (**Fig. 4**).
- Insert lever (**Fig. 27 ref. 1**) between the rim and the bead on the right-hand side of the tool.

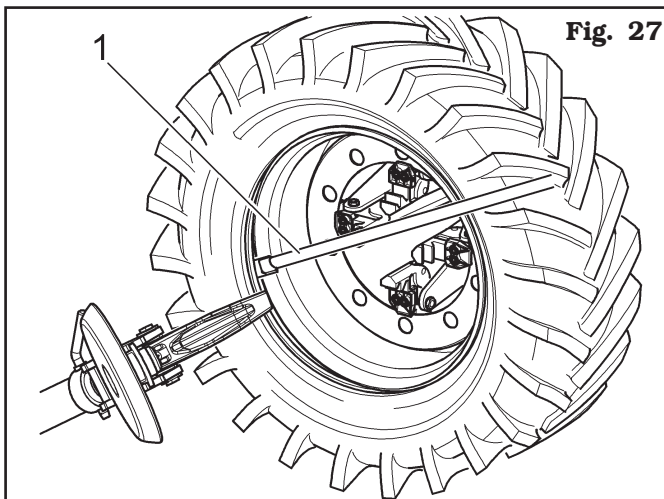
**Fig. 27**

- Keeping the lever pressed lower the wheel until the edge of the rim is 5 mm (0.2”) distant from the hook tool.
- Turn the wheel clockwise by keeping lever pressed until the bead has gone completely out.
- Move the tool holder arm away in “off-work” position (**Fig. 15 ref. 1**); lower the chuck until the tyre rests on the footboard ; exert a certain pressure on it so that when the chuck is moved slightly backwards, this will create the space required to extract the inner pipe.
- Extract the inner pipe and lift the wheel again.
- Move to work position **D** (**Fig. 4**).
- Tilt up tool holder arm, unhook it and lift it placing it in “off-work” position (**Fig. 15 ref. 1**); use the handle control to position the tool holder arm on the inner side of the wheel then place it in work position (**Fig. 14 ref. 1**) and secure with the safety hook provided (**Fig. 1 ref. 8**).
- Carry out the tools holder head 180° rotation, according to the descriptions in the relevant paragraph, in order to insert the hook between the rim edge and the tyre bead; the operation must be carried out during chuck rotation.
- Move the rim away from the tool by about 4-5 cm (1.6”- 2”) to avoid possible unhooking of the bead from the same tool.
- Move to work position **A** (**Fig. 4**).
- Translate the hook tool outwards until the reference notch is 3 cm inside the rim.
- Insert the lever (**Fig. 28 ref. 1**) between rim (**Fig. 28 ref. 2**) and bead (**Fig. 28 ref. 3**) on the tool right.

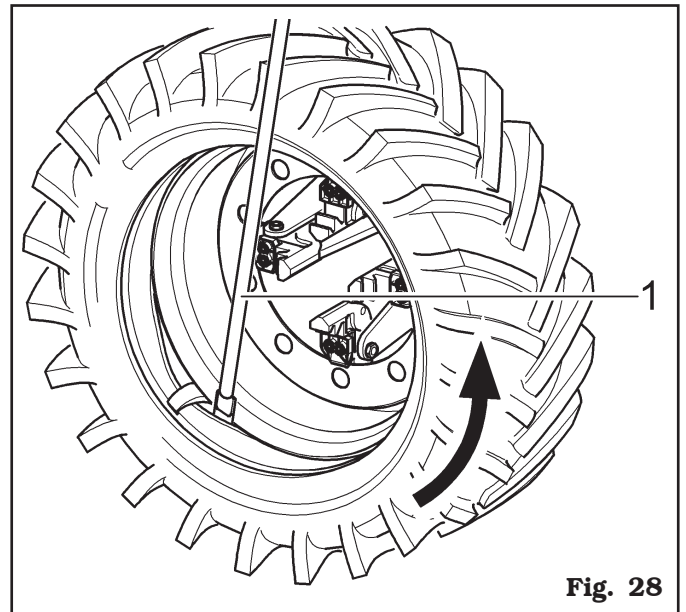
**Fig. 28**

- Keeping the lever pressed, lower the wheel until the edge of the rim is approximately 5 mm (0.2") distant from the hook tool then turn the chuck counterclockwise keeping the lever (**Fig. 28 ref. 1**) pressed until the tyre has been completely dislodged from the rim.



**THE REMOVAL OF THE BEADS FROM THE RIM CAUSES THE TYRE TO FALL. ALWAYS MAKE SURE THAT NO ONE IS STANDING BY ACCIDENT IN THE WORK AREA.**



**WHEN DEMOUNTING VERY HEAVY TYRES, IT IS IMPORTANT TO MOVE THE WHEEL AS CLOSE AS POSSIBLE TO THE BASE BEFORE COMPLETING THE OPERATION.**

### 12.7.3 Mounting



**THROUGHOUT TYRE MOUNTING/DEMOUNTING OPERATIONS, CHECK THAT THE SELF-CENTRING CHUCK CLAMPING PRESSURE IS CLOSE TO THE MAX. OPERATING VALUE (160 - 180 BAR / 2320 - 2610 PSI).**

- Secure the rim to the chuck according to the procedure described in paragraph "WHEEL CLAMPING".
- Adequately lubricate tyre beads and rim bead seats with a suitable lubricant using the supplied brush.



**USE ONLY TYRE LUBRICANTS. SUITABLE LUBRICANTS CONTAIN NO WATER, HYDROCARBONS, OR SILICONE.**

- Mount clamp (**Fig. 23 ref. 1**) on the external edge of the rim in the highest point as shown in **Fig. 23**.



**THE CLAMP MUST BE TIGHTLY SECURED TO THE EDGE OF THE RIM.**

- Move to work position **B** (**Fig. 4**).
- Position the tyre on the footboard and lower the chuck (make sure the clamp is at the highest point) to hook the first tyre bead (internal bead).

- Lift the chuck arm with the tyre hooked and turn it counterclockwise about 15-20 cm (5.9"- 7.9"); the tyre will position itself sideways with respect to the rim.
- Tilt up tool holder arm, unhook it and lift it placing it in "off-work" position (**Fig. 15 ref. 1**); use the handle control to position the tool holder arm on the inner side of the wheel then place it in work position (**Fig. 14 ref. 1**) and secure with the safety hook provided.



**PAY ATTENTION WHEN REPOSITIONING THE TOOLS HOLDER ARM TO AVOID CRUSHING HANDS.**



**ALWAYS MAKE SURE THAT THE ARM IS CORRECTLY HOOKED TO CARRIAGE.**

- Carry out the tools holder head 180° rotation, according to the descriptions in the relevant paragraph, in order to insert the hook between the rim edge and the tyre bead; the operation must be carried out during chuck rotation.
- Move to work position **D** (**Fig. 4**).
- Move the tool forward until the axis of the reference notch matches that of the external edge of the rim at about 5 mm (0.2") from the rim itself (see **Fig. 29**).

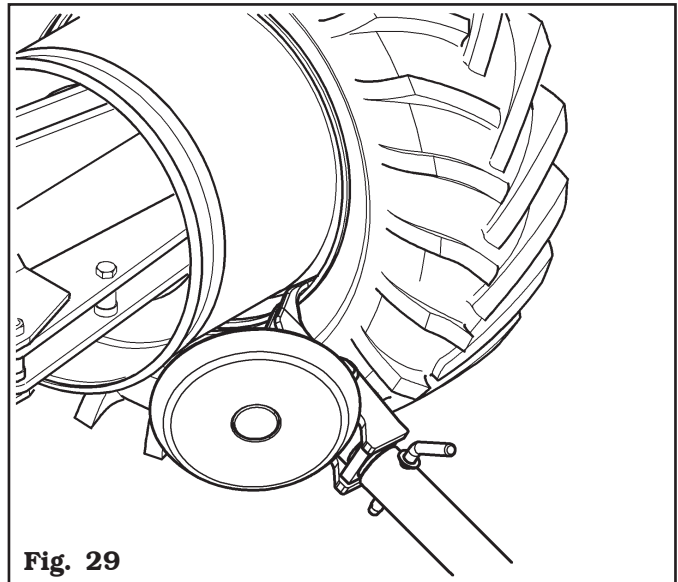

**Fig. 29**

- Move to work position **C** (**Fig. 4**).
- From the external side of the wheel, check the exact position of the tool and, if necessary, correct it, then, turn the chuck clockwise until the clamp reaches the lowest point ("6 o'clock"). The first bead should now be inserted in the rim, then remove clamp.

- Move to work position **D** (**Fig. 4**).
- Extract the tool hook from the tyre.
- Place the tools holder arm in “out of work” position (**Fig. 15 ref. 1**) and translate it to the outer side of the tyre.
- Carry out the tools holder head 180° rotation, according to the descriptions in the relevant paragraph.
- Move to work position **B** (**Fig. 4**).
- Turn the chuck to position the hole to insert the valve downward (“6 o’clock”).
- Lower the chuck until the wheel rests on the foot-board. Move the chuck backward to create the necessary space between tyre edge and rim for the introduction of the inner pipe.

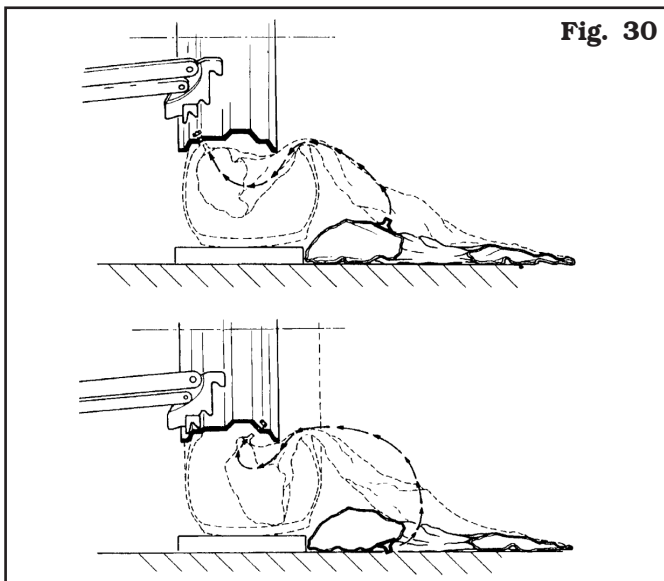

**THE VALVE HOLE COULD BE IN AN ASYMMETRIC POSITION WITH RESPECT TO THE CENTRE OF THE RIM. IN THIS CASE IT IS NECESSARY TO POSITION AND INTRODUCE THE INNER PIPE AS SHOWN IN FIG. 30.**

**Fig. 30**

Introduce the valve in the hole and secure it with the provided ring nut. Introduce the inner pipe in the central groove of the rim (to make this operation easier, it is advisable to simultaneously turn the chuck clockwise).

- Turn the chuck and position the valve downwards (“6 o’clock”).
- To avoid damaging the inner pipe, slightly inflate it when inserting the second bead.
- To avoid damaging the valve when securing the second bead, remove the fixing ring nut and mount an extension on the same valve.
- Move to work position **C** (**Fig. 4**).

- Lift the chuck and mount the clamp (**Fig. 31 ref. 1**) on the rim outside the second bead at about 20 cm (7.9” from the inflating valve on the right).
- Turn the chuck clockwise until clamp (**Fig. 31 ref. 1**) is positioned at “9 o’clock”.

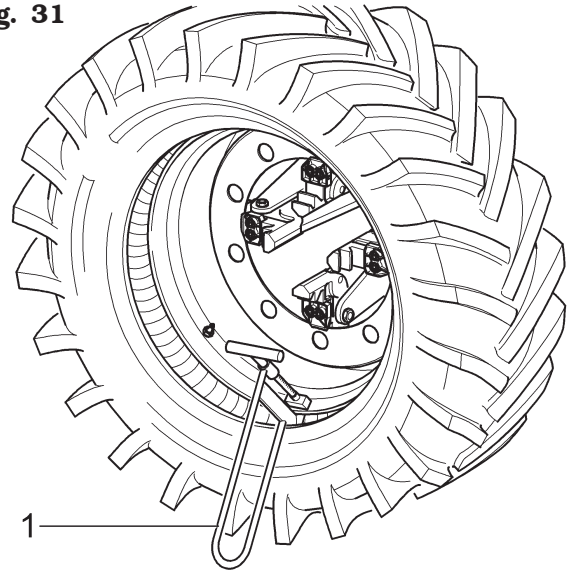
**Fig. 31**

- Place the tool holder arm in “work position” (**Fig. 14 ref. 1**) on the outer side of the tyre.
- Place the hook tool in work position and bring the tool holder arm forward until the axis of the reference notch matches that of the outer edge of the rim at a distance of 5 mm (0.2”).
- Turn the chuck clockwise until lever (**Fig. 32 ref. 1**) is introduced in the housing obtained on the hook tool.
- Turn the chuck with lever (**Fig. 32 ref. 1**) hooked up to the complete insertion of the tyre outer bead.
- Remove lever (**Fig. 32 ref. 1**), clamp (**Fig. 32 ref. 2**) and extract the hook tool by turning the chuck counterclockwise and translating it outwards.

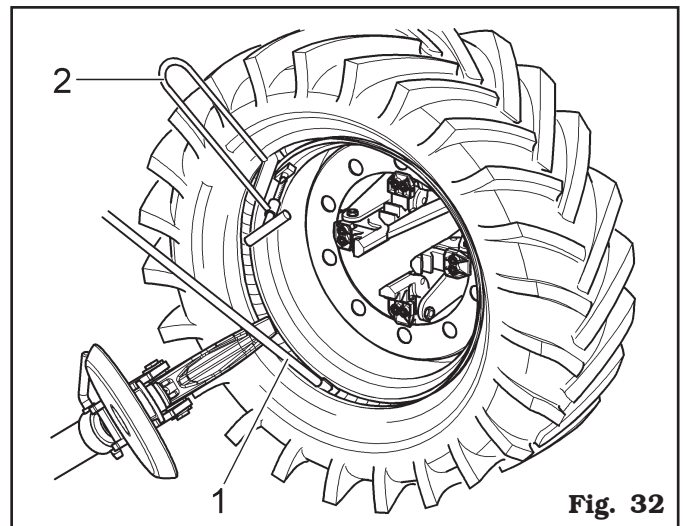
**Fig. 32**

- Tilt up tool holder arm placing it in “out of work” position (**Fig. 15 ref. 1**) after it has been unhooked.
- Lower the chuck until the wheel rests on the foot-board.
- Move to work position **B** (**Fig. 4**).
- Check the condition of the tyre valve and centre it in the rim hole if necessary, by slightly turning the chuck; secure the valve with the supplied ring nut after removing the protective extension.
- Close the chuck clamps completely, making sure the wheel is held up to avoid dropping.



**MAKE SURE THAT THE WHEEL'S HOLD IS SECURE TO AVOID IT FALLING DURING REMOVAL. FOR HEAVY AND/OR VERY LARGE WHEELS USE AN ADEQUATE LIFTING DEVICE.**

- Translate the platform to release the wheel from the chuck.

## 12.8 Wheels with bead wire

As an example **Fig. 33** and **Fig. 34** illustrate sections and compositions of types of wheels with bead wire currently being sold.

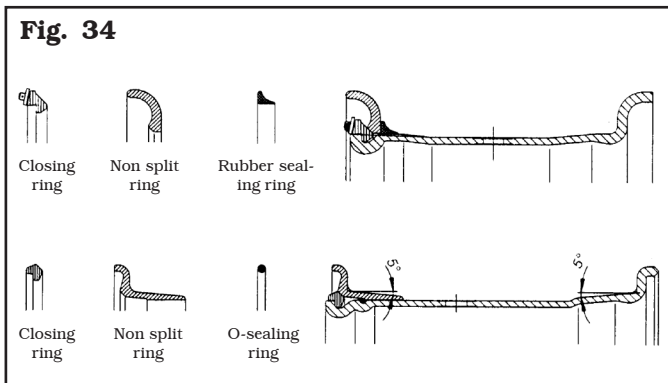
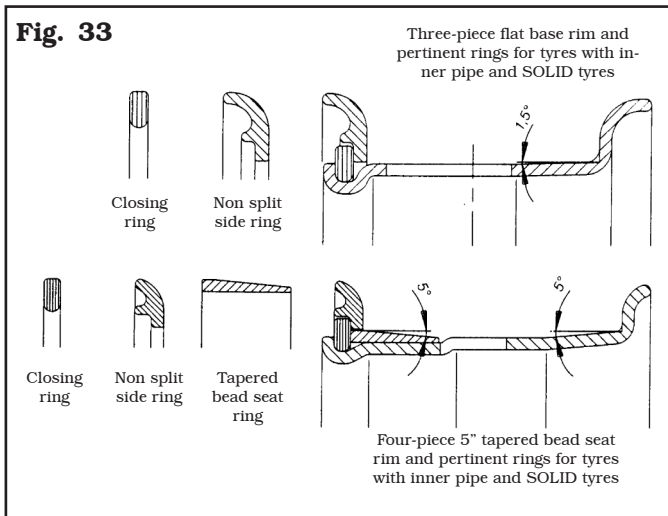

### 12.8.1 Beading and demounting



**NEVER STAND IN FRONT OF THE WHEEL WHILE THE INFLATION RING IS BEING EXTRACTED FROM THE BEAD WIRE, SINCE IT MAY BE EJECTED VIOLENTLY, CAUSING SERIOUS INJURIES OR WOUNDS.**



**THROUGHOUT TYRE MOUNTING/DEMOUNTING OPERATIONS, CHECK THAT THE SELF-CENTRING CHUCK CLAMPING PRESSURE IS CLOSE TO THE MAX. OPERATING VALUE (160 - 180 BAR / 2320 - 2610 PSI).**

- Mount the wheel on the chuck as described in “WHEEL CLAMPING” and make sure it is deflated.
- Move to work position **D** (**Fig. 4**).
- Place the tool arm in “work position” (**Fig. 14 ref. 1**) in the tyre inner side, and make sure it is locked by the provided safety stop (**Fig. 1 ref. 8**).
- Position the bead breaking disc on rim edge (see **Fig. 35**).

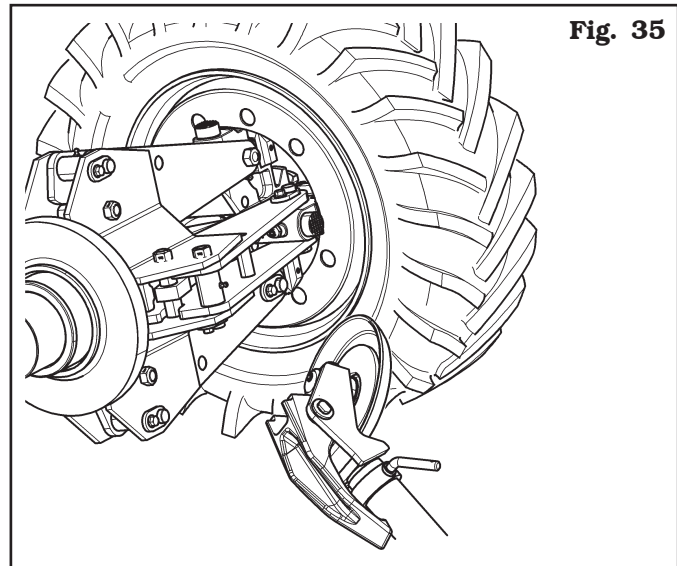

- Turn the chuck and smear the entire bead seat of the rim with lubricant. While doing this, jerk the bead breaking disc forward until the first bead is removed (as these wheels feature inner pipes, carry out the operation carefully, paying special attention to when the bead dislodges, trying to stop disc advance immediately to avoid compromising the integrity of the inner pipe and valve).
- Place the tools holder arm in “out of work” position (**Fig. 15 ref. 1**), operate the handle control in order to position the tools holder arm on the wheel outer side, then place it in “working” position (**Fig. 14 ref. 1**) again and lock it with the safety hook provided.

- Carry out tools holder head 180° rotation according to the description of the relevant paragraph, in order to let the bead breaking disc come into contact with the tyre outer side (see Fig. 36).

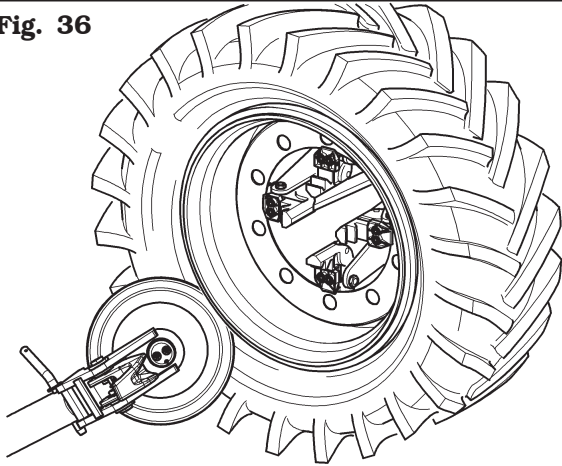
**Fig. 36**

- Turn the chuck and smear the entire bead seat of the rim with lubricant.
- While doing this, jerk the bead breaking disc forward until bead is removed.
- Repeat the operation, making the bead breaking disc move forward against the bead wire (see Fig. 37) up to the stop ring is released (Fig. 37 ref. 1). It will be then extracted through lever (Fig. 37 ref. 2).

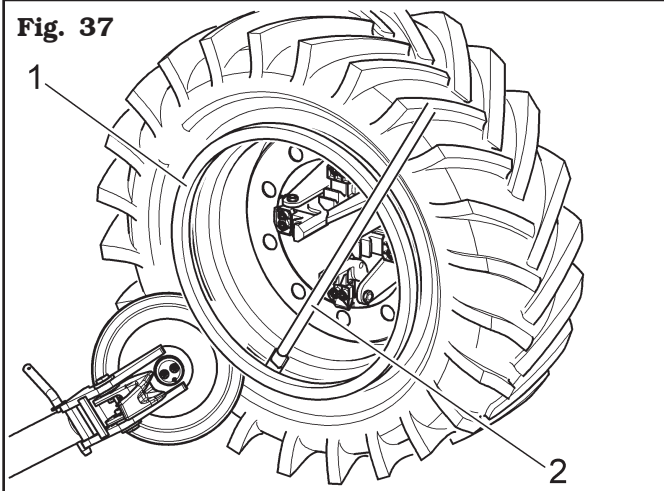
**Fig. 37**

- Remove the bead wire.
- Remove the O-Ring, when featured.
- Tilt up tool holder arm placing it in “out of work” position (Fig. 15 ref. 1) after it has been unhooked.
- Lower the chuck until the wheel rests on the foot-board.
- Move to work position B (Fig. 4).
- Move the chuck backward until the tyre is completely dislodged from the rim (in case of tyres with inner pipe, make sure the valve hasn't been damaged during removal).



**THE REMOVAL OF THE BEADS FROM THE RIM CAUSES THE TYRE TO FALL. ALWAYS MAKE SURE THAT NO ONE IS STANDING BY ACCIDENT IN THE WORK AREA.**



**WHEN DEMOUNTING VERY HEAVY TYRES, IT IS IMPORTANT TO MOVE THE WHEEL AS CLOSE AS POSSIBLE TO THE BASE BEFORE COMPLETING THE OPERATION.**



**PAY ATTENTION WHEN REPOSITIONING THE TOOLS HOLDER ARM TO AVOID CRUSHING HANDS.**



**ALWAYS MAKE SURE THAT THE ARM IS CORRECTLY HOOKED TO CARRIAGE.**

### **12.8.2 Mounting**



**THROUGHOUT TYRE MOUNTING/DEMOUNTING OPERATIONS, CHECK THAT THE SELF-CENTRING CHUCK CLAMPING PRESSURE IS CLOSE TO THE MAX. OPERATING VALUE (160 - 180 BAR / 2320 - 2610 PSI).**

- Place the tools holder arm in off-work position (Fig. 15 ref. 1); if it has been removed, secure the rim to the chuck as described in “WHEEL CLAMPING” paragraph. If the wheel features an inner pipe, position the rim with the valve slot facing downwards (at “6 o'clock”).
- Lubricate the entire bead seat of the rim and the tyre beads.
- Move to work position B (Fig. 4).
- Place the chuck in order to centre the rim on the tyre.
- Operate chuck forward movement in order to insert the rim in the tyre (in case of tyres with inner pipe, make the valve re-enter in order not to damage it). Move forward until the rim is completely inserted in the tyre.
- Insert the bead wire on the rim with the stop ring fitted (if the rim and bead wire feature fixing slits, they must be in phase with each other).
- Move to work position C (Fig. 4).

- Place the tools holder arm on the external side then lower it into “work position” (**Fig. 14 ref. 1**) with the bead breaking disc facing the wheel. If the outer edge ring is not sufficiently fitted on the rim, position the chuck until the bead wire is near the bead breaking disc. Move the bead breaking disc forward and then turn the chuck until the housing of the O-Ring (if featured) is found.
- Lubricated the O-Ring and place it in its housing.
- Move to work position **B** (**Fig. 4**).
- Position the bead wire (**Fig. 38 ref. 1**) on the rim, fit the stop ring with the help of the bead breaking disc as shown in **Fig. 38**.

Fig. 38

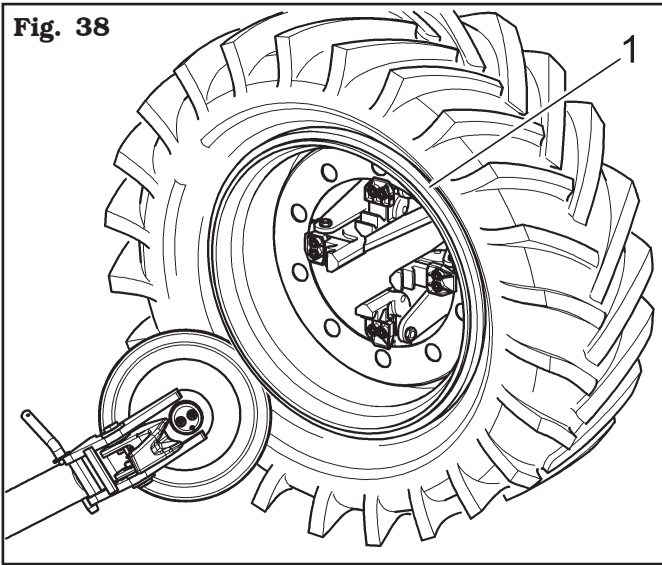

- Tilt up tool holder arm placing it in “out of work” position (**Fig. 15 ref. 1**) after it has been unhooked.
- Lower the chuck until the wheel rests on the foot-board.
- Close the chuck clamps completely and translate the platform outwards until the rim has been completely removed, making sure the wheel is held up to avoid dropping.



**CLOSING THE CHUCK CAUSES THE WHEEL TO FALL. ALWAYS MAKE SURE THAT NO ONE IS STANDING BY ACCIDENT IN THE WORK AREA.**

### 13.0 ROUTINE MAINTENANCE



**BEFORE CARRYING OUT ANY ROUTINE MAINTENANCE OR ADJUSTMENT PROCEDURE, DISCONNECT THE EQUIPMENT FROM THE ELECTRICITY SUPPLY USING THE SOCKET/PLUG COMBINATION AND CHECK THAT ALL MOBILE PARTS ARE AT A STANDSTILL.**



**BEFORE EXECUTING ANY MAINTENANCE OPERATION, MAKE SURE THERE ARE NO WHEELS LOCKED ONTO THE CHUCK.**



**BEFORE REMOVING HYDRAULIC CIRCUIT FITTING OR PIPES, MAKE SURE THAT THERE ARE NO PRESSURISED FLUIDS PRESENT. PRESSURISED OIL SPILLS MAY CAUSE SERIOUS WOUNDS OR INJURIES.**



**BEFORE CARRYING OUT ANY MAINTENANCE WORK ON THE HYDRAULIC CIRCUIT, SET THE MACHINE IN THE REST CONDITION.**

To guarantee the efficiency and correct functioning of the machine, it is essential to carry out daily or weekly cleaning and weekly routine maintenance, as described below

Cleaning and routine maintenance must be conducted by authorized personnel and according to the instructions given below:

- Disconnect the equipment from the electrical and pneumatic power supplies before carrying out any cleaning operations.
- Remove deposits of tyre powder and other waste materials with a vacuum cleaner.
- **NEVER BLOW WITH COMPRESSED AIR.**
- Periodically (preferably once a month) make a complete check on the controls, ensuring that they provide the specified actions.
- Every 100 working hours lubricate the (tool and chuck) carriage sliding guides.
- Periodically (preferably once a month), grease all moving parts of the machine (see **Fig. 39**).

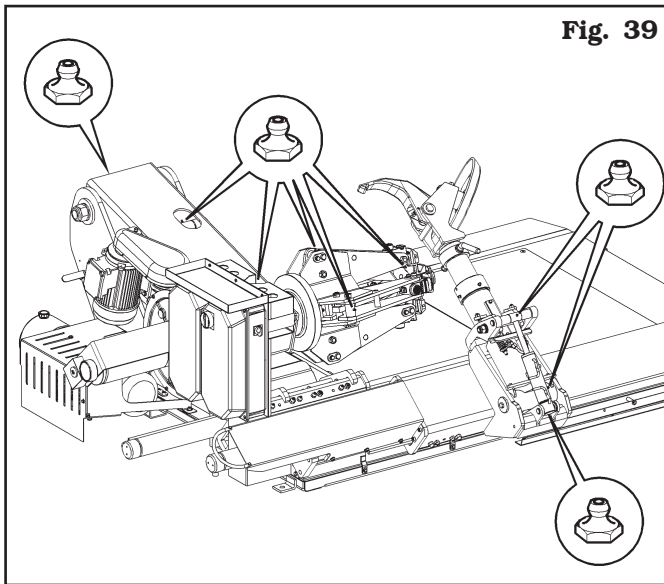

**Fig. 39**

- Check periodically the oil level of the oil-pressure unit and, in case, carry out the filling up with hydraulic oil having a viscosity degree suitable for the average temperatures of the country where the machine is installed and in particular:

- viscosity 32 (or countries with room temperature from 0 °C ÷ +30 °C (+32 °F ÷ +86 °F);

- viscosity 46 (for countries with room temperature above 30 degrees (+86 °F).

At least once a year it is advisable to proceed anyway to the complete replacement of the hydraulic oil of the same oil-pressure unit.



**PERFORM THIS OPERATION ONLY WITH THE MACHINE COMPLETELY CLOSED (HYDRAULIC PISTONS EXTENDED).**

- Periodically (about every 100 hours), check the oil level of the reduction gear and eventually reset the level.
- Check operation of the safety devices every week.
- Periodically (every 50 working hours approximately), carry out the (inner and outer) guides of the tool and chuck carriages.

- A.** Place the whole support (**Fig. 40 ref. 1**) in horizontal position, then check the reduction gear oil level (**Fig. 40 ref. 2**); the level indicator window (**Fig. 40 ref. 3**) must be covered with lubricant, otherwise, remove the plug (**Fig. 40 ref. 4**) and top up using appropriate lubricants until the level is reset.

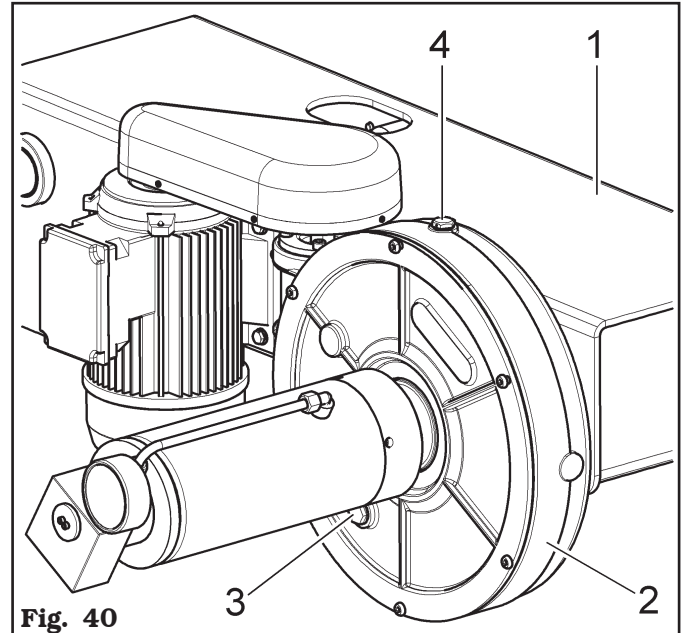
**Fig. 40**

- B.** Check belt tensioning (**Fig. 41 ref. 1**):

- Remove the upper guard (**Fig. 41 ref. 2**) with a screwdriver.
- Stretch the belt (**Fig. 41 ref. 1**) using the screw (**Fig. 41 ref. 3**) after the nuts (**Fig. 41 ref. 4**); have been slackened.
- Tighten the fixing nuts (**Fig. 41 ref. 4**) after the adjustment operations, then assemble the protection guard (**Fig. 41 ref. 2**) again.

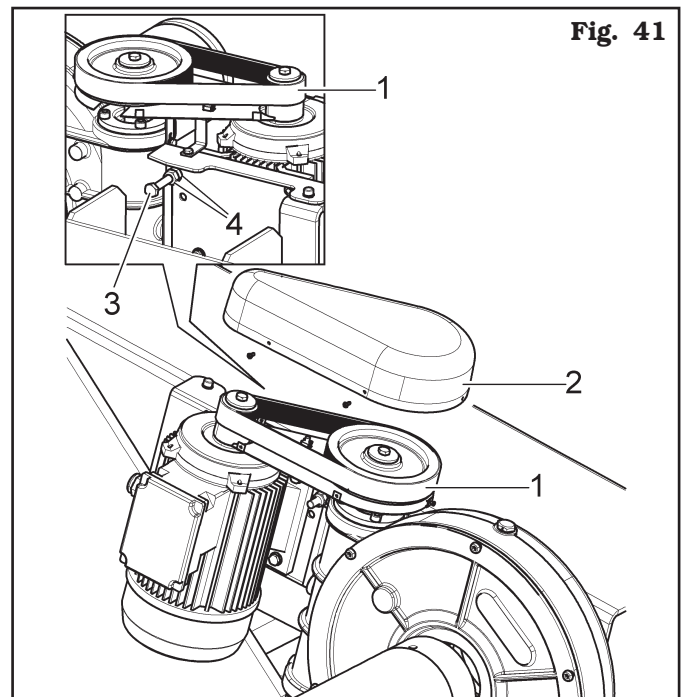
**Fig. 41**

C. Check periodically and, if necessary, adjust the play of slide (**Fig. 42 ref. 1**) on guide plates (**Fig. 42 ref. 2**) by means of the adjustment bolts (**Fig. 42 ref. 3**) of sliding blocks (**Fig. 42 ref. 4**).

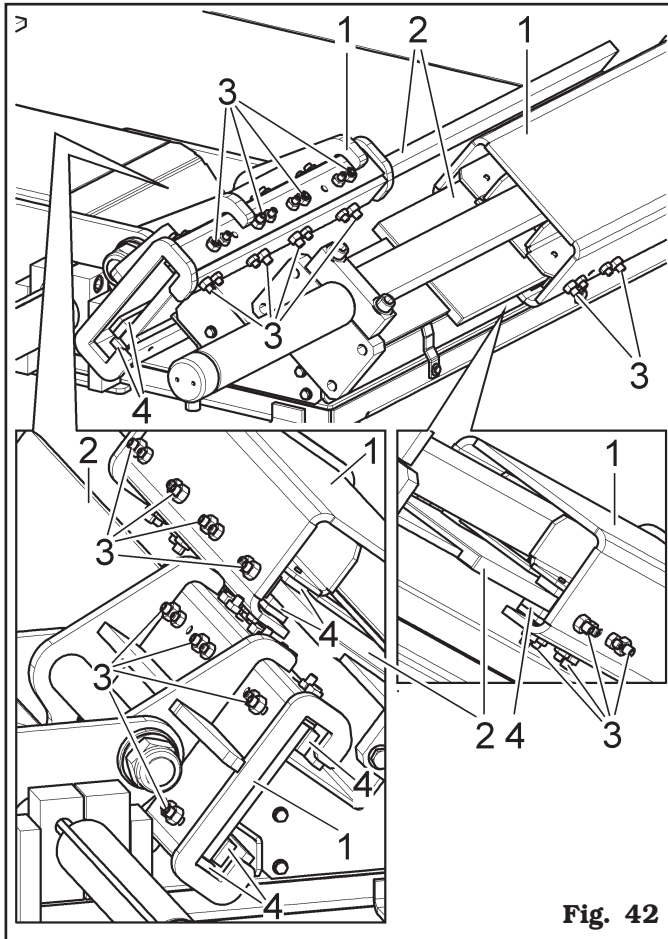
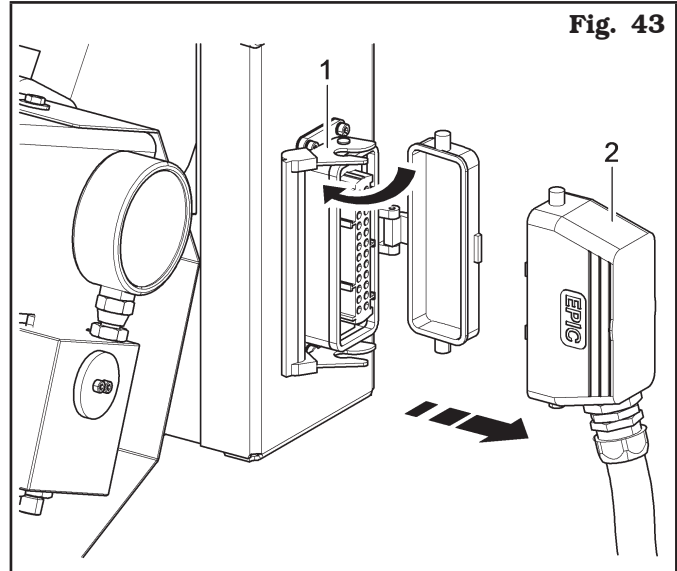

**Fig. 42**

**13.1 Manipulator cable replacement**

If you need to quickly replace the manipulator cable as it is damaged, proceed as follows:

- Open the locking device (**Fig. 43 ref. 1**).
- replace the damaged cable (**Fig. 43 ref. 2**).
- secure the locking device.



**Fig. 43**

**i** OPERATION TO BE CARRIED OUT ONLY IN CASE THE CARRIAGE MOVES IN A NON-LINEAR WAY (TRIGGER ACTION).

**!** ANY DAMAGE TO THE MACHINE DEVICES RESULTING FROM THE USE OF LUBRICANTS OTHER THAN THOSE RECOMMENDED IN THIS MANUAL WILL RELEASE THE MANUFACTURER FROM ANY LIABILITY!!







**!** ANY EXTRAORDINARY MAINTENANCE OPERATION MUST BE CARRIED OUT EXCLUSIVELY BY PROFESSIONALLY QUALIFIED PERSONNEL.



**14.0 TROUBLESHOOTING TABLE**

Possible troubles which might occur to the tyre-changer are listed below. The manufacturer disclaims all responsibility for damages to people, animals or objects due to improper operation by non-authorized personnel. In case of trouble, call Technical Service Department for instructions on how to service and/or adjust the machine in full safety to avoid any risk of damage to people, animals or objects.

In an emergency and before maintenance on tyre-changer, set the main switch to "0" and lock it in this position.

**CONTACT AUTHORIZED TECHNICAL SERVICE****do not try and service alone**

<b>Problem</b>	<b>Possible cause</b>	<b>Remedy</b>
Pump motor does not work but wheel holder chuck motor works perfectly.	a) Hydraulic control unit damaged.	a) Call Technical Service Dept. 
When main switch is turned on, wheel holder chuck does not turn whereas the pump motor works.	a) Gearbox change-over switch damaged.	a) Call Technical Service Dept. 
Power drop during wheel holder chuck rotation.	a) Timing belt too loose.	a) Tension up the belt.
No pressure in the hydraulic system.	a) Pump damaged.	a) Replace pump. 
The chuck opening pressure does not go down.	a) Pressure limiting valve jammed	a) Download chuck (remove wheel), completely undo adjusting handle. Perform many opening and closing cycles up to jam release. 
The machine does not start.	a) No power supply. b) Overload cutouts not set. c) Transformer fuse blown.	a) Connect the power supply. b) Set the overload cutouts. c) Change the fuse.
Fluid leaks from fitting or pipeline.	a) Fitting not tightened correctly. b) Pipeline cracked.	a) Tighten the fitting. b) Call the after-sales service. 
A control device is remaining on.	a) The switch has broken. b) A solenoid valve has jammed.	a) Call the after-sales service. b) Call the after-sales service. 
The self-centring chuck cylinder is losing pressure.	a) The directional control valve is leaking. b) The gaskets are worn.	a) Call the after-sales service. b) Call the after-sales service. 
The motor stops during operation.	a) Overload cutout tripped.	Open the electrical cabinet and reset the overload cutout tripped.

<b>Problem</b>	<b>Possible cause</b>	<b>Remedy</b>
When a control device is operated the machine does not move at all.	<ul style="list-style-type: none"> <li><b>a)</b> Solenoid valve not receiving power.</li> <li><b>b)</b> Solenoid valve jammed.</li> <li><b>c)</b> Transformer fuse blown.</li> <li><b>d)</b> Control unit not set correctly.</li> </ul>	<ul style="list-style-type: none"> <li><b>a)</b> Call the after-sales service.</li> <li><b>b)</b> Call the after-sales service.</li> <li><b>c)</b> Change the fuse.</li> <li><b>d)</b> Call the after-sales service.</li> </ul> 
No pressure in hydraulic circuit.	<ul style="list-style-type: none"> <li><b>a)</b> Power unit motor turning in wrong direction.</li> <li><b>b)</b> Power unit pump has failed.</li> <li><b>c)</b> No oil in power unit tank.</li> </ul>	<ul style="list-style-type: none"> <li><b>a)</b> Restore correct rotation direction by changing socket connection.</li> <li><b>b)</b> Call the after-sales service.</li> <li><b>c)</b> Fill power unit tank with oil</li> </ul> 
Machine operates in jerks.	<ul style="list-style-type: none"> <li><b>a)</b> Not enough fluid in power unit tank.</li> <li><b>b)</b> Control unit switch has failed.</li> </ul>	<ul style="list-style-type: none"> <li><b>a)</b> Top up with oil.</li> <li><b>b)</b> Call the after-sales service.</li> </ul> 

## 15.0 TECHNICAL DATA

### 15.1 Technical electrical data

		NAV43	NAV63	Version 230V 50Hz 3Ph	Version 500V 50Hz 3Ph	Version 220V 60Hz 3Ph	Version 230V 50Hz 3Ph	Version 220V 60Hz 3Ph
Motor power (kW)		1.3-1.85	1.5-2.2	1.3-1.85	1.5-2.2			1.3-1.85
Power supply	Voltage (V)	400		230	500	230		220
	Phases	3						
	Frequency (Hz)	50				60	50	60
Hydraulic drive unit motor (kW)		1.85-2.5						
Power supply	Voltage (V)	400		230	500	230		220
	Phases	3						
	Frequency (Hz)	50				60	50	60
Typical current draw (A)		12.5	13.5	21.5	11.5	24	23.5	22.5
Self-centring chuck rotation speed (revolutions/min)		4-8						

### 15.2 Technical mechanical data

	NAV43	NAV63
Maximum tyre diameter (mm)	2360 (93")	2700 (106")
Rim maximum diameter (inches)	11 - 42	
Max. wheel width (mm)	1500 (59")	
Max. rotation torque (Nm)	5300 (3906 ft.lbs)	5800 (4275 ft.lbs)
Max. wheel weight (kg)	2300 (5070 lbs)	2600 (5732 lbs)
Self-centring chuck clamping (inches)	11 ÷ 56 (with extensions)	11 ÷ 60 (with extensions)
Minimum locking hole (mm)	90 (3.54")	
Bead-breaking force (N)	32000 (7194 lbf)	37000 (8318 lbf)
Gear noise (dB) (A)	< 80	
Operating pressure (bar)	160 (2320 psi)	180 (2610 psi)
Weight (Kg)	1150 (2536 lbs)	1400 (3087 lbs)

NAV43

Fig. 44

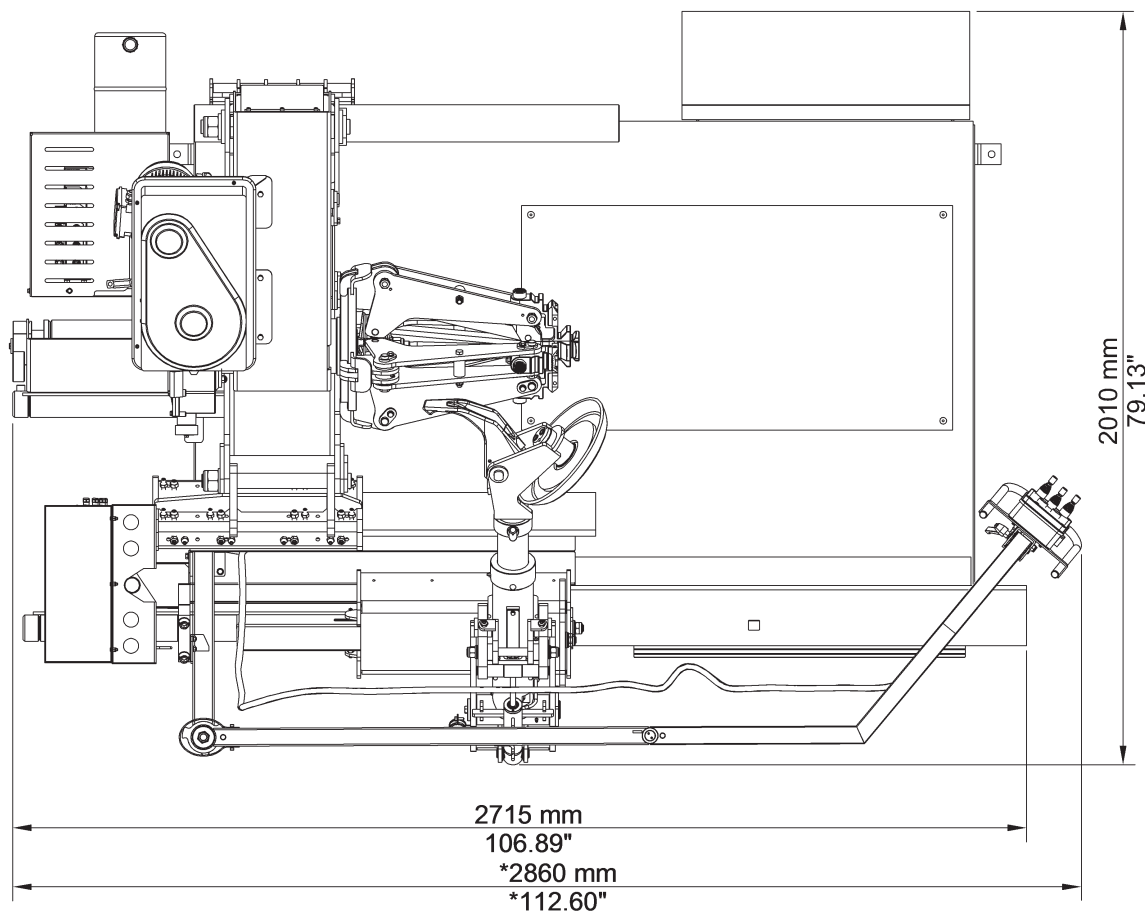
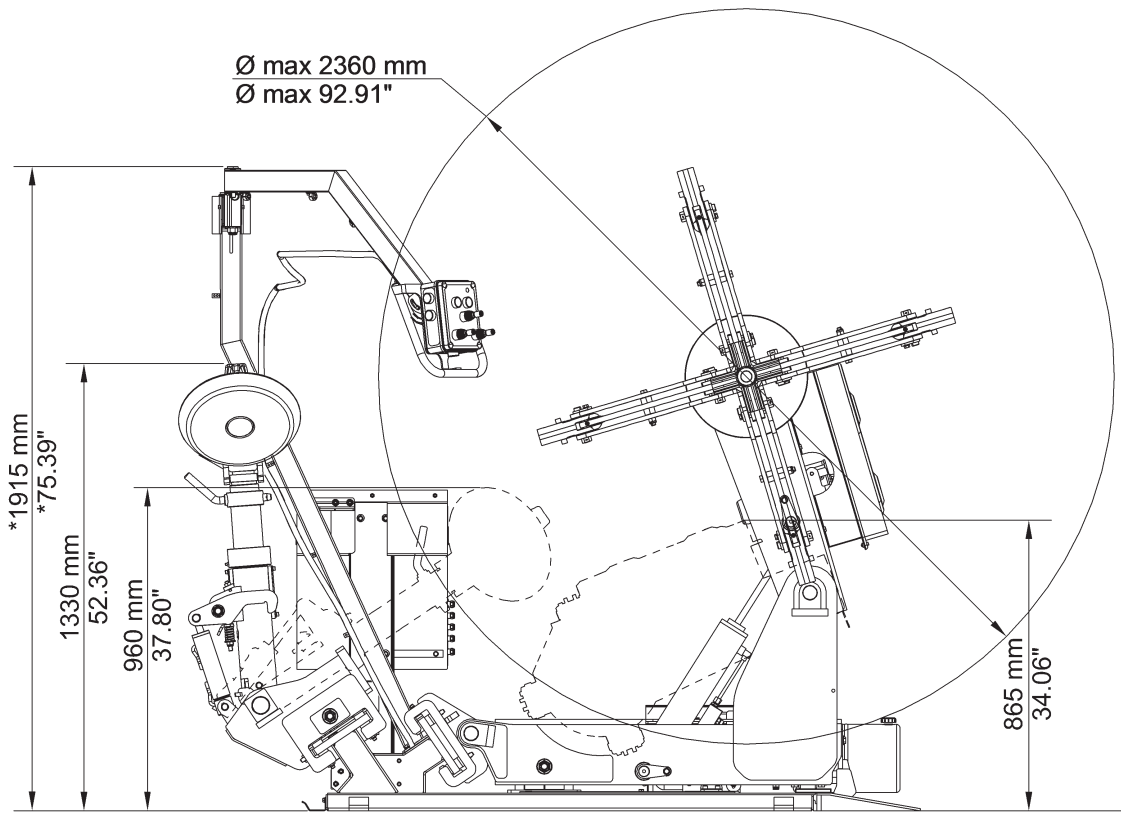

\* Apply to versions with aerial control

NAV63

Fig. 45

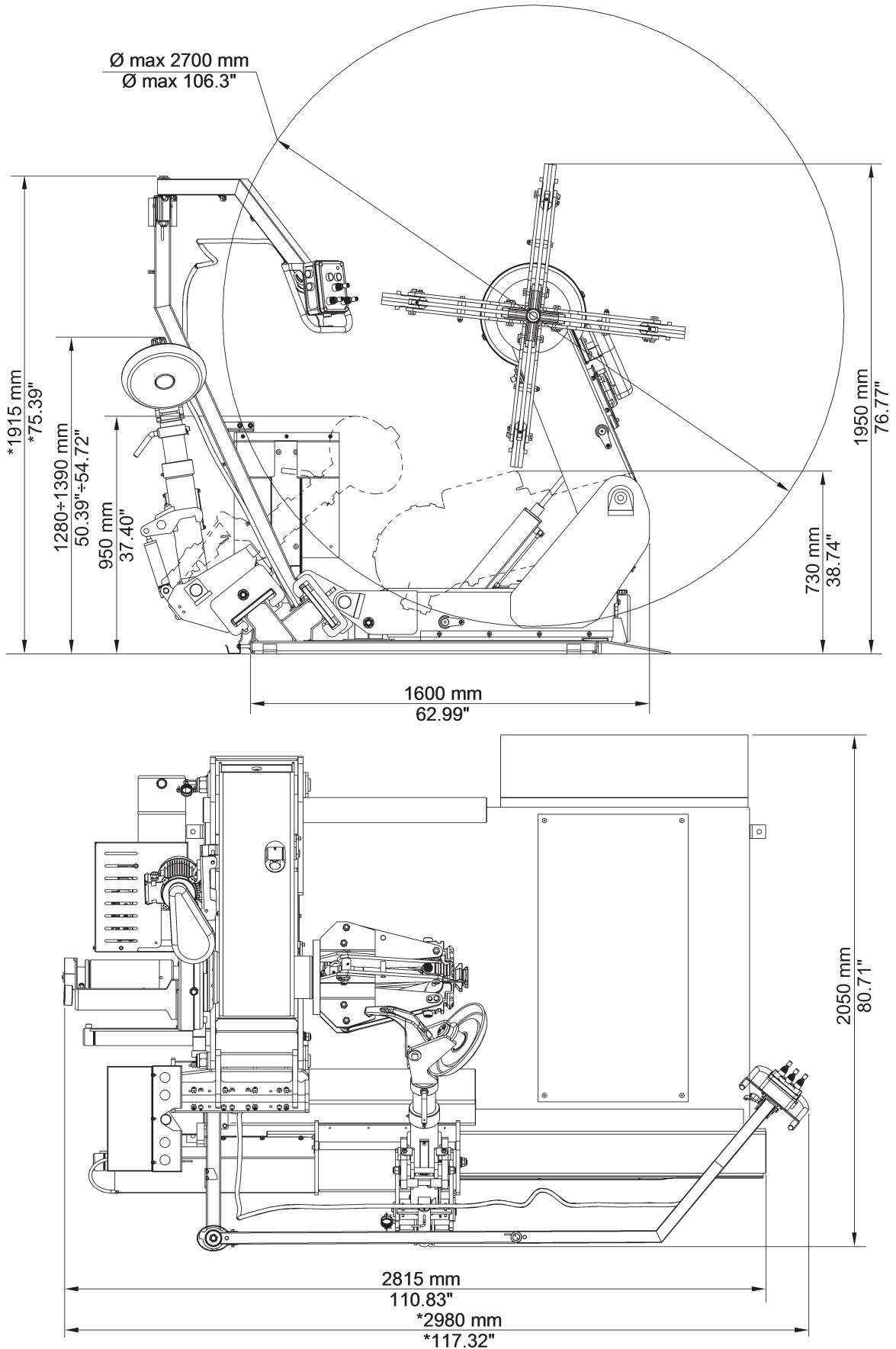

\* Apply to versions with aerial control

**16.0 STORING**

If storing for long periods (6 months or longer) disconnect the main power supply and take measures to protect the machine from dust build-up. Lubricate parts that could be damaged from drying out. When putting the machine back into operation replace the rubber pads and the mounting tool. Moreover, carry out a verification of machine perfect functioning.

**17.0 SCRAPPING**

When the decision is taken not to make further use of the machine, it is advisable to make it inoperative by removing the connection pressure pipes. The machine is to be considered as special waste and should be dismantled into homogeneous parts. Dispose of it in accordance with current legislation.

**Instructions for the correct management of waste from electric and electronic equipment (WEEE) according to the Italian legislative decree 49/14 and subsequent amendments.**

In order to inform the users on the correct way to dispose the product (as required by the article 26, paragraph 1 of the Italian legislative decree 49/14 and subsequent amendments), we communicate what follows: the meaning of the crossed dustbin symbol reported on the equipment indicates that the product must not be thrown among the undifferentiated rubbish (that is to say together with the “mixed urban waste”), but it has to be managed separately, to let the WEEE go through special operations for their reuse or treatment, in order to remove and dispose safely the waste that could be dangerous for the environment and to extract and recycle the raw materials to be reused.

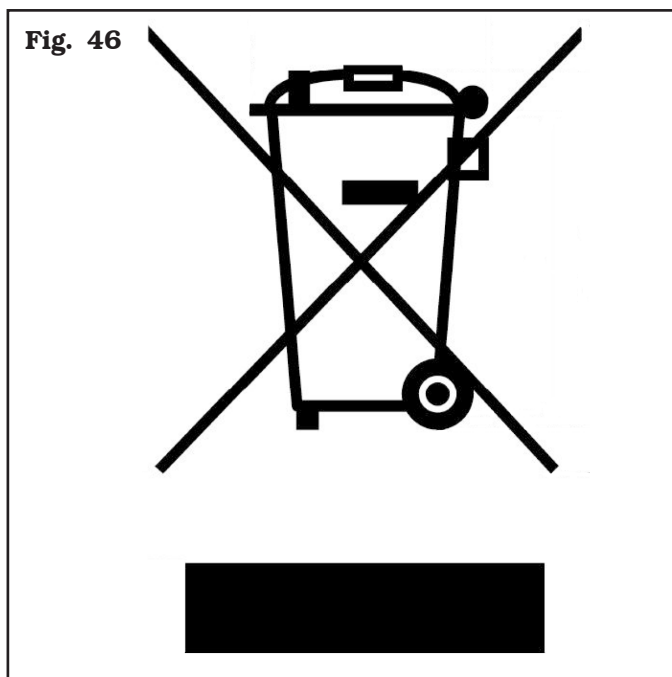

**18.0 REGISTRATION PLATE DATA**

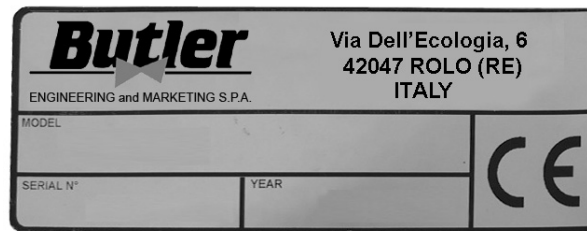

**The validity of the Conformity Declaration enclosed to this manual is also extended to products and/or devices the machine model object of the Conformity Declaration can be equipped with.**

**Said plate must always be kept clean from grease residues or filth generally.**

**ATTENTION: TAMPERING WITH, CARVING, CHANGING ANYHOW OR EVEN REMOVING MACHINE IDENTIFICATION PLATE IS ABSOLUTELY FORBIDDEN; DO NOT COVER IT WITH TEMPORARY PANELS, ETC., SINCE IT MUST ALWAYS BE VISIBLE.**

*WARNING: Should the plate be accidentally damaged (removed from the machine, damaged or even partially illegible) inform immediately the manufacturer.*

**19.0 FUNCTIONAL DIAGRAMS**

Here follows a list of the machine functional diagrams.



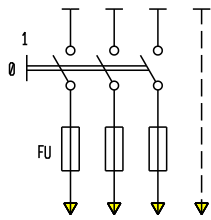

INSTALLAZIONE A CARICO DEL CLIENTE  
INSTALLATION BY AUTHORIZED OPERATORS

FU	V	
	230	400
50	16A aM	10A aM
60	16A aM	10A aM

CAVO D'ALIMENTAZIONE 3P + TERRA x 2.5 mmq  
SUPPLY CABLE 3P + GROUND x 2.5 mmq

- MORSETTI QS2  
CLAMP QS2
- 16 = S/L2
  - 14 = R/L1
  - 3 = T/L3
  - 15 = V/T2
  - 13 = U/T1
  - 4 = W/T3
  - 7 = 2
  - 5 = 1
  - 8 = 3

- MORSETTI IRM  
CLAMP IRM
- 11 = T/L3
  - 7 = S/L2
  - 3 = R/L1
  - 12 = W
  - 8 = V
  - 2 = U

CONNETTORE  
CONNECTOR

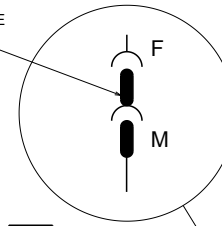

1 mmq blu  
1 mmq blue  
1 mmq marrone  
1 mmq brown

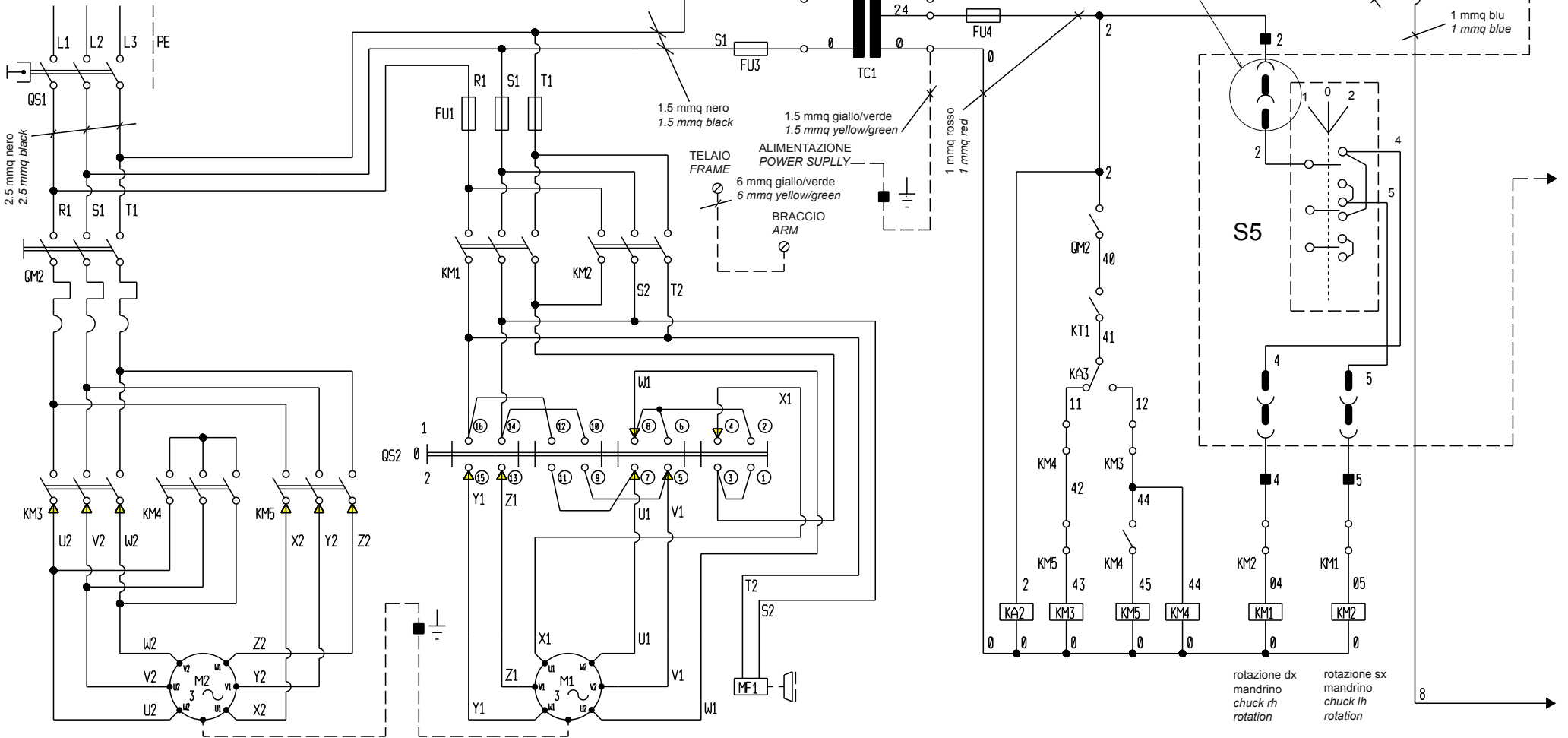

**Butler**

ENGINEERING and MARKETING S.P.A.

LISTA DEI COMPONENTI - LIST OF COMPONENTS - TEILELISTE  
LISTE DES PIÈCES DÉTACHÉES - LISTA DE PIEZAS

Tavola N°A - Rev. 5

752205782

SCHEMA ELETTRICO 1/4  
ELECTRICAL SCHEME 1/4  
SCHALTPLAN 1/4  
SCHEMA ELECTRIQUE 1/4  
ESQUEMA ELECTRICO 1/4

Pag. 44 di 88

NAV43.15 - NAV63.15

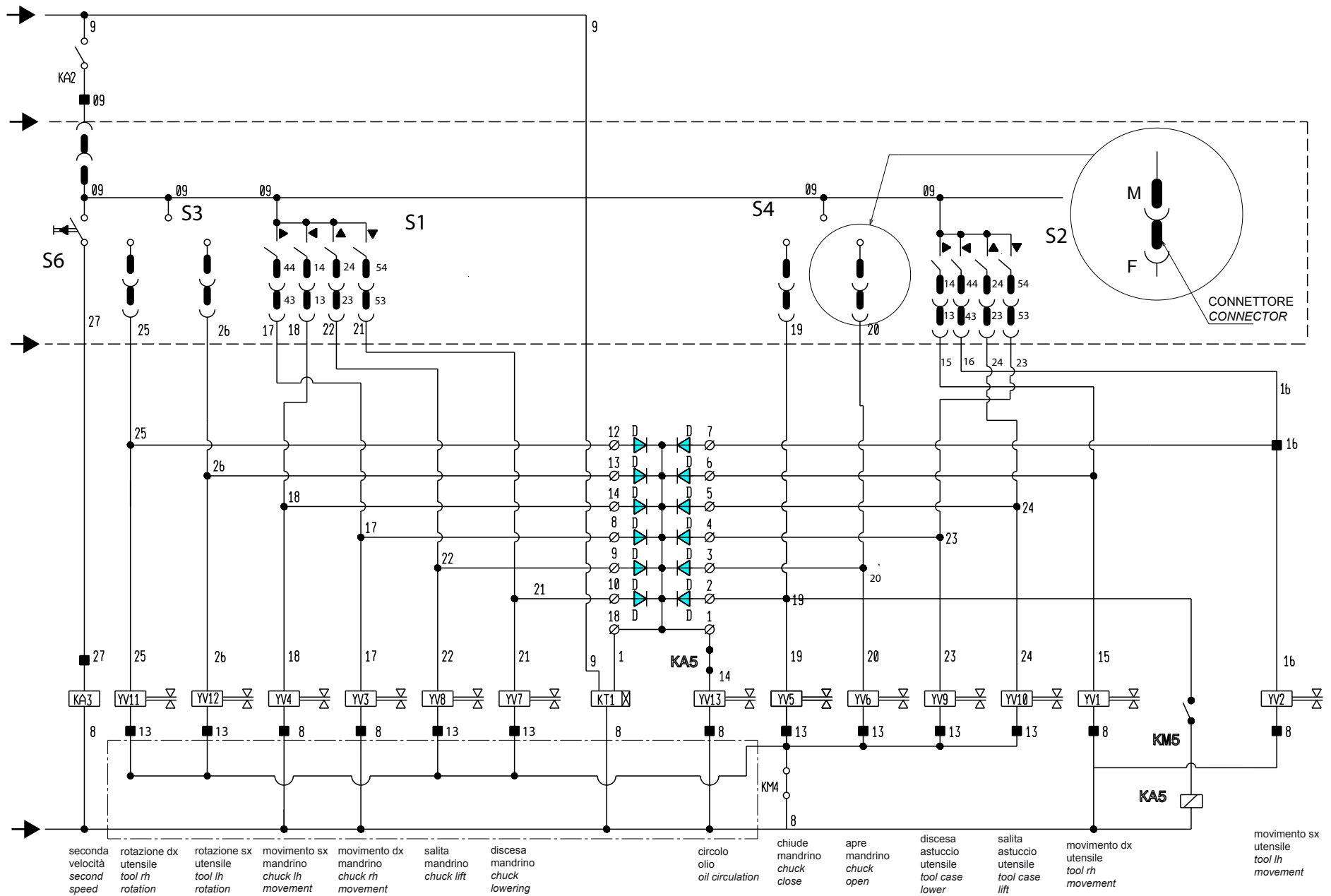

	CODICE CENTRALINA HYDRAULIC POWER UNIT CODE
MACCHINE NAV63/ NAV63 MACHINE	752292610
MACCHINE NAV43/ NAV43 MACHINE	752290510

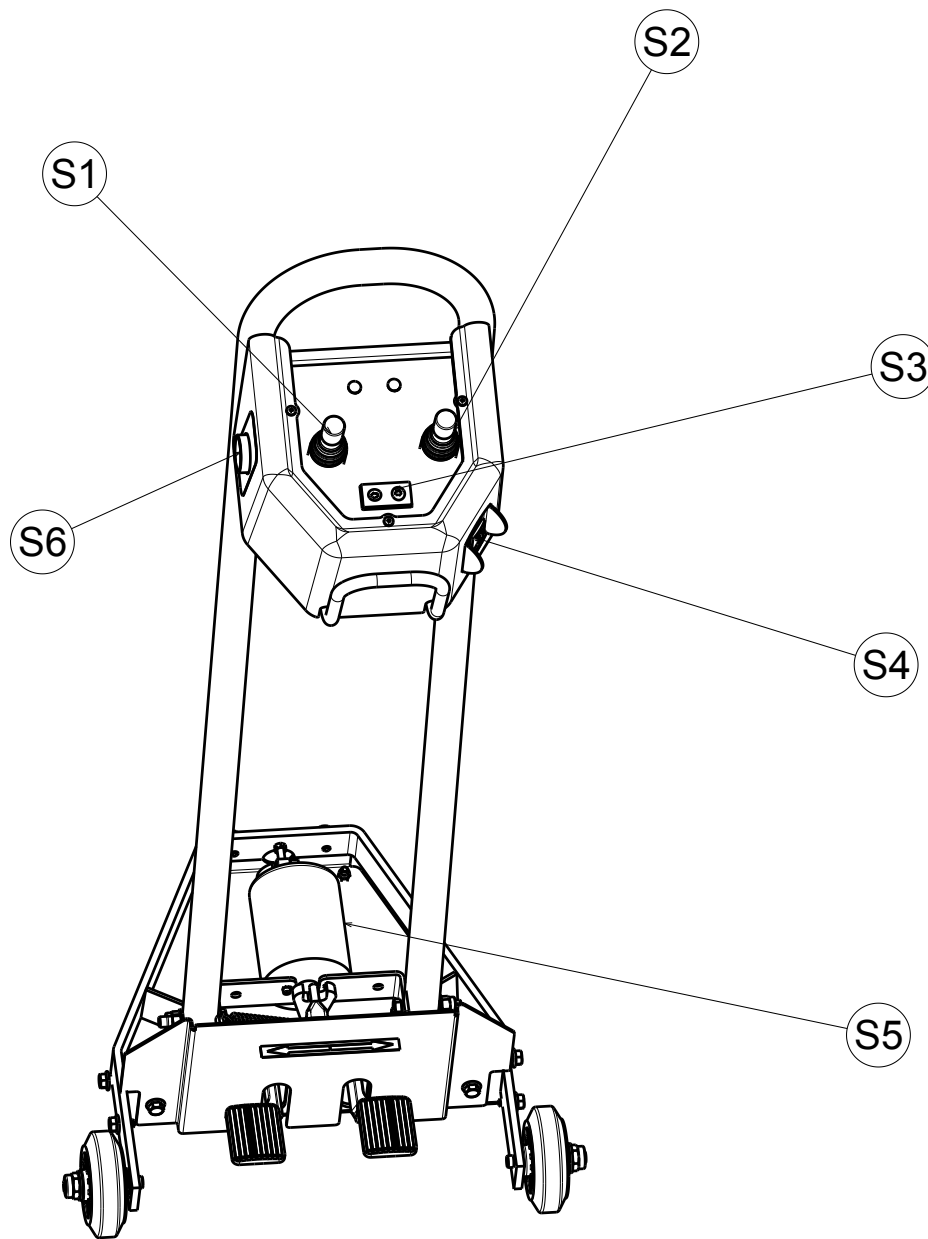
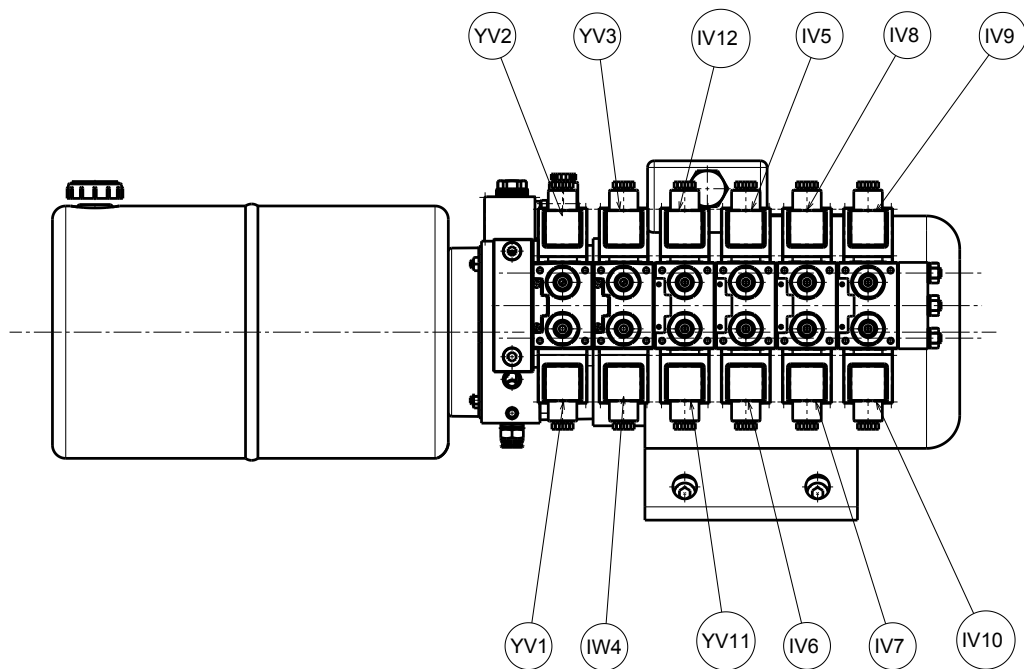

N°	Cod.	Descrizione	Description
	C	Condensatore elettrolitico	Electrolytic condenser
	D	Diodo 1N4007	1N4007 diode
	FU1	Fusibile protezione linea	Line guard fuse
	FU3	Fusibile protezione primario	First guard fuse
	FU4	Fusibile protezione secondario	Second guard fuse
	FU5	Fusibile protezione secondario	Second guard fuse
	KA2	Relè blocco comandi	Controls block relay
	KA3	Relè comando seconda velocità	Relay commande second speed
	KA5	Relè inibitore elettrovalvola in seconda velocità	Second speed solenoid valve inhibitor relay
	KM1	Contattore rotazione oraria mandrino	Chuck clockwise rot. Contactor
	KM2	Contattore rotazione antioraria mandrino	Chuck anticlockwise rot. Contactor
	KM3	Contattore comando prima velocità	First speed control contactor
	KM4/KM5	Contattore comando seconda velocità	Second speed control contactor
	KT1	Timer comando motore centralina	Hydraulic power unit control timer
	MF1	Freno motore mandrino	Chuck motor brake
	S5	Commutatore comando rotazione mandrino	Chuck rotation control commutator
	S2	Manipolatore comando carro utensile avanti/indietro e salita/discesa	Handle for tool carriage forward/backward control
	S1	Manipolatore comando salita/discesa mandrino e movimento sx / movimento dx mandrino	Handle for chuck up/down control handle and chuck lh / rh movement
	M1	Motore mandrino	Chuck motor
	M2	Motore centralina	Hydraulic power unit motor
	QM2	Interruttore magnetotermico	Magnetic-thermique switch
	QS1	Interruttore generale	Main switch
	QS2	Commutatore di poli	Pole commutator
	S4	Pulsante apre/chiude mandrino	Chuck open/close push-button
	S3	Pulsante comando rotazione utensili dx/sx	Rh/lh tools rotation control push-button
	S6	Pulsante seconda velocità centralina	Hydraulic power unit second speed push-button
	TC1	Trasformatore comandi	Control transformer
	VC1	Ponte raddrizzatore	Bridge
	YV1	Elettrovalvola movimento dx utensile	Tool rh movement solenoid valve
	YV2	Elettrovalvola movimento sx utensile	Tool lh movement solenoid valve
	YV3	Elettrovalvola movimento dx mandrino	Chuck rh movement solenoid valve
	YV4	Elettrovalvola movimento sx mandrino	Chuck lh movement solenoid valve
	YV5	Elettrovalvola chiude mandrino	Chuck closing solenoid valve
	YV6	Elettrovalvola apre mandrino	Chuck opening solenoid valve
	YV7	Elettrovalvola discesa mandrino	Chuck descent solenoid valve
	YV8	Elettrovalvola salita mandrino	Chuck rising solenoid valve
	YV9	Elettrovalvola entra utensile	Tool "in" solenoid valve
	YV10	Elettrovalvola esce utensile	Tool "out" solenoid valve
	YV11	Elettrovalvola rotazione Synodx	Rotation solenoid valve Synodx
	YV12	Elettrovalvola rotazione Synosx	Synosx rotation solenoid valve
	YV13	Elettrovalvola circolo olio	Oil circulation solenoid valve
	■	Morsetto	Morsetto

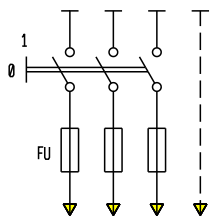

INSTALLAZIONE A CARICO DEL CLIENTE  
INSTALLATION BY AUTHORIZED OPERATORS

FU	HZ	V	230	400
		50	16A aM	10A aM
	60	16A aM	10A aM	

CAVO D'ALIMENTAZIONE 3P + TERRA x 2.5 mmq  
SUPPLY CABLE 3P + GROUND x 2.5 mmq

MORSETTI QS2  
CLAMP QS2

16 = S/L2  
14 = R/L1  
3 = T/L3  
15 = V/T2  
13 = U/T1  
4 = W/T3  
7 = 2  
5 = 1  
8 = 3

MORSETTI IRM  
CLAMP IRM

11 = T/L3  
7 = S/L2  
3 = R/L1  
12 = W  
8 = V  
2 = U

Valido nella variante comando aereo  
Valid for aerial control version  
Gültig für Version mit Luftbetätigung  
Valide en la version avec commande aérien  
Válido en la versión mando aéreo

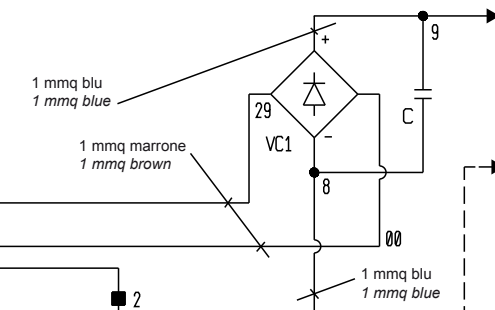
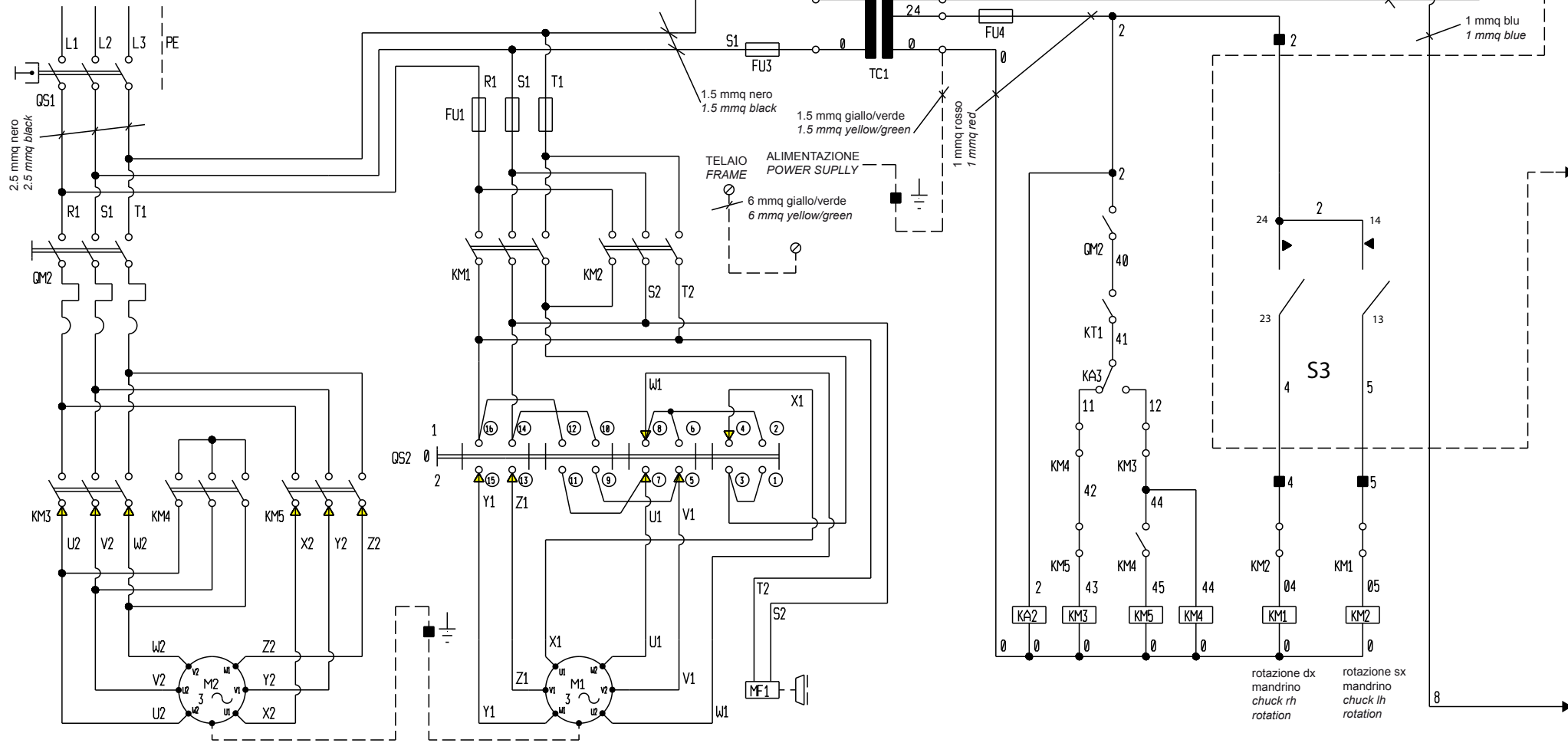

rotazione dx mandrino  
chuck rh rotation

rotazione sx mandrino  
chuck lh rotation



LISTA DEI COMPONENTI - LIST OF COMPONENTS - TEILELISTE  
LISTE DES PIÈCES DÉTACHÉES - LISTA DE PIEZAS

Tavola N°B - Rev. 4

752205661

SCHEMA ELETTRICO 1/3  
ELECTRICAL SCHEME 1/3  
SCHALTPLAN 1/3  
SCHEMA ELECTRIQUE 1/3  
ESQUEMA ELECTRICO 1/3

Pag. 48 di 88  
NAV43.15 - NAV63.15

Valido nella variante comando aereo  
 Valid for aerial control version  
 Gültig für Version mit Luftbetätigung  
 Valide en la version avec commande aérien  
 Válido en la versión mando aéreo

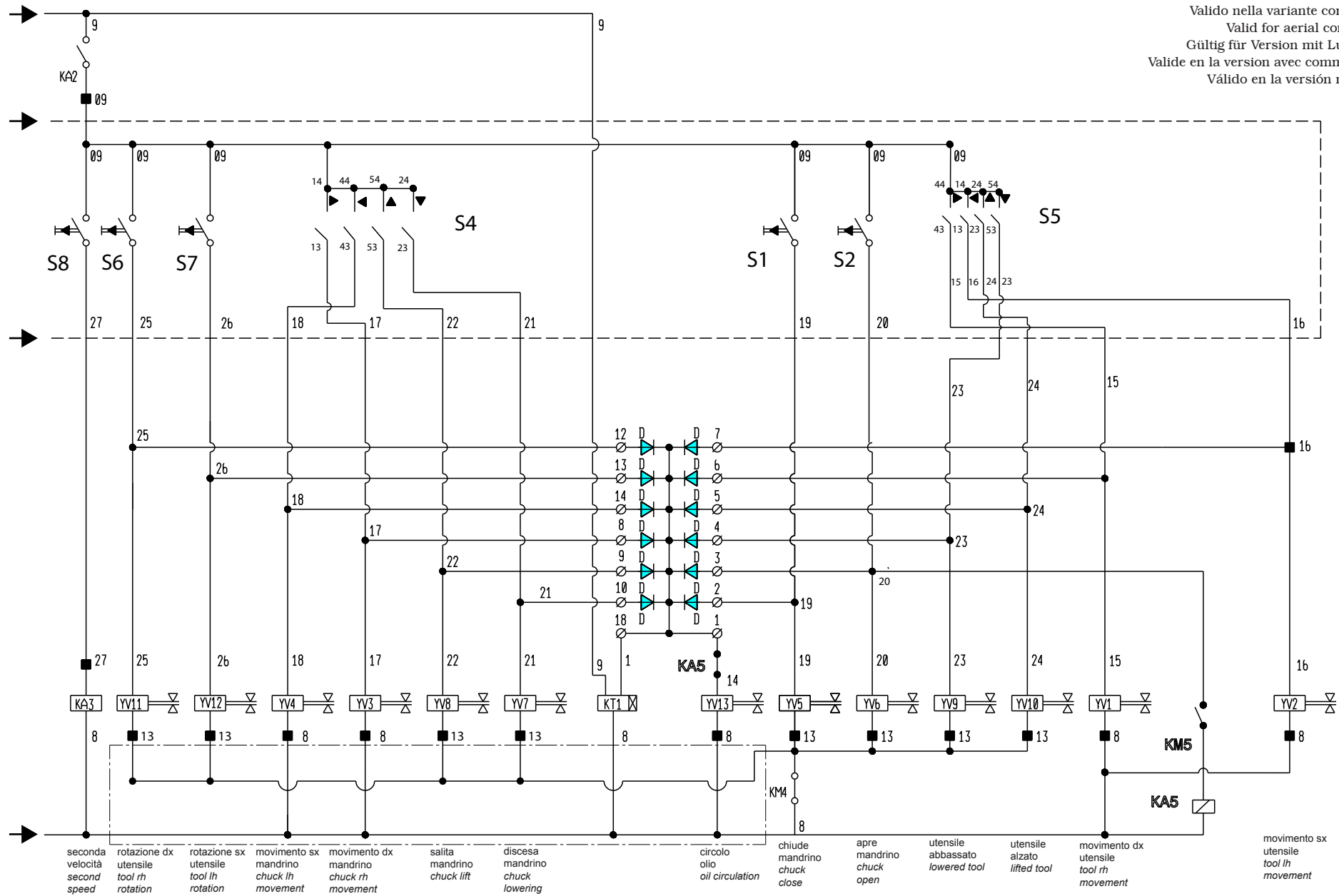

N°	Cod.	Descrizione	Description
	C	Condensatore elettrolitico	Electrolytic condenser
	D	Diodo 1N4007	1N4007 diode
	FU1	Fusibile protezione linea	Line guard fuse
	FU3	Fusibile protezione primario	First guard fuse
	FU4	Fusibile protezione secondario	Second guard fuse
	FU5	Fusibile protezione secondario	Second guard fuse
	KA2	Relè blocco comandi	Controls block relay
	KA3	Relè comando seconda velocità	Relay commande second speed
	KA5	Relè inibitore elettrovalvola in seconda velocità	Second speed solenoid valve inhibitor relay
	KM1	Contattore rotazione oraria mandrino	Chuck clockwise rot. Contactor
	KM2	Contattore rotazione antioraria mandrino	Chuck anticlockwise rot. Contactor
	KM3	Contattore comando prima velocità	First speed control contactor
	KM4/KM5	Contattore comando seconda velocità	Second speed control contactor
	KT1	Timer comando motore centralina	Hydraulic power unit control timer
	MF1	Freno motore mandrino	Chuck motor brake
	S3	Manipolatore comando rotazione mandrino	Chuck rotation control handle
	S5	Manipolatore comando salita/discesa utensile e movimento sx/dx utensile	Handle for tool up/down control handle and tool lh/rh movement
	S4	Manipolatore comando salita/discesa mandrino e movimento sx/dx mandrino	Handle for chuck up/down control handle and chuck lh/rh movement
	M1	Motore mandrino	Chuck motor
	M2	Motore centralina	Hydraulic power unit motor
	QM2	Interruttore magnetotermico	Magnetic-thermique switch
	QS1	Interruttore generale	Main switch
	QS2	Commutatore di poli	Pole commutator
	SB1	Pulsante chiude mandrino	Chuck close push-button
	SB2	Pulsante apre mandrino	Chuck open push-button
	S6	Pulsante comando rotazione utensile	Tool rotation control push-button
	S7	Pulsante comando rotazione utensile	Tool rotation control push-button
	S8	Pulsante seconda velocità centralina	Hydraulic power unit second speed push-button
	TC1	Trasformatore comandi	Control transformer
	VC1	Ponte raddrizzatore	Bridge
	YV1	Elettrovalvola movimento dx utensile	Tool rh movement solenoid valve
	YV2	Elettrovalvola movimento sx utensile	Tool lh movement solenoid valve
	YV3	Elettrovalvola movimento dx mandrino	Chuck rh movement solenoid valve
	YV4	Elettrovalvola movimento sx mandrino	Chuck lh movement solenoid valve
	YV5	Elettrovalvola chiude mandrino	Chuck closing solenoid valve
	YV6	Elettrovalvola apre mandrino	Chuck opening solenoid valve
	YV7	Elettrovalvola discesa mandrino	Chuck descent solenoid valve
	YV8	Elettrovalvola salita mandrino	Chuck rising solenoid valve
	YV9	Elettrovalvola entra utensile	Tool "in" solenoid valve
	YV10	Elettrovalvola esce utensile	Tool "out" solenoid valve
	YV11	Elettrovalvola rotazione Synodx	Synorh rotation solenoid valve
	YV12	Elettrovalvola rotazione Synosx	Synolh rotation solenoid valve
	YV13	Elettrovalvola circolo olio	Oil circulation solenoid valve
	■	Morsetto	Morsetto

Valido nella versione con manipolatore Bluetooth  
 Valid for Bluetooth handle control version  
 Gültig für Version mit Bluetooth-Manipulator  
 Valide dans la version avec manipulateur Bluetooth  
 Válido en la versión con manipulador Bluetooth

Valido nella variante 230V 50Hz 3Ph  
 Valid for 230V 50Hz 3Ph version  
 Gültig für 230V 50Hz 3Ph Version  
 Valide en la version 230V 50Hz 3Ph  
 Válido en la versión 230V 50Hz 3Ph

Valido nella variante 230V 60Hz 3Ph  
 Valid for 230V 60Hz 3Ph version  
 Gültig für 230V 60Hz 3Ph Version  
 Valide en la version 230V 60Hz 3Ph  
 Válido en la versión 230V 60Hz 3Ph

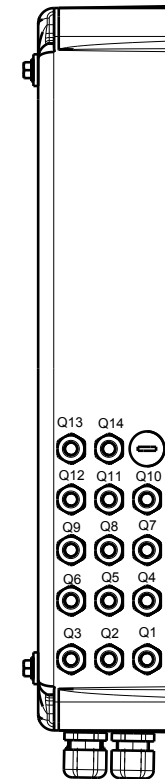
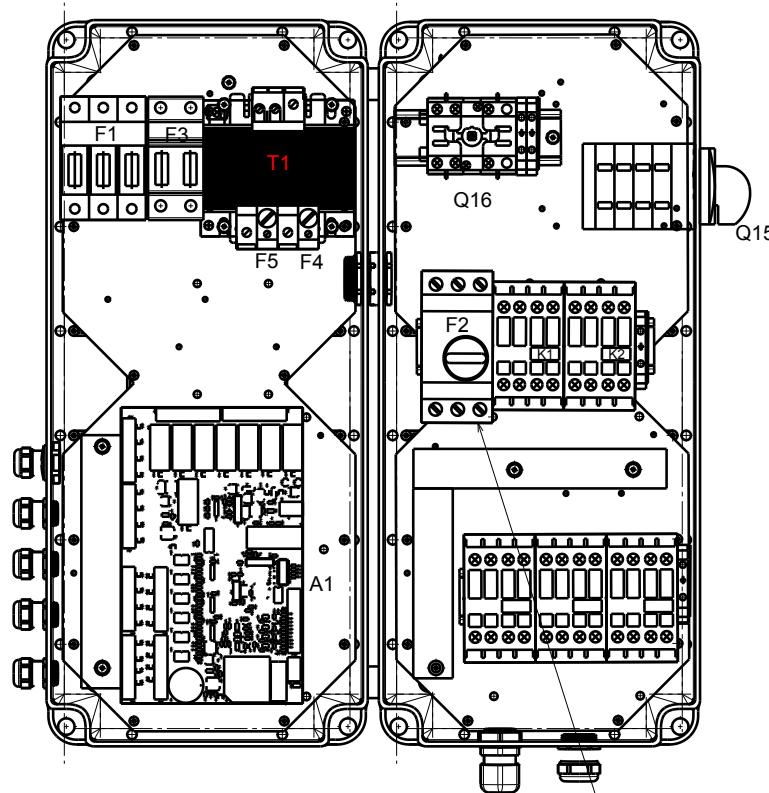
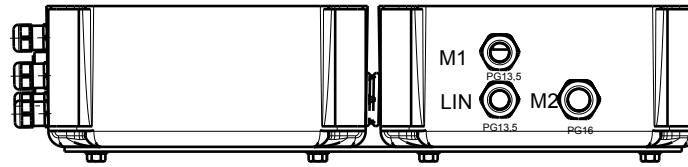
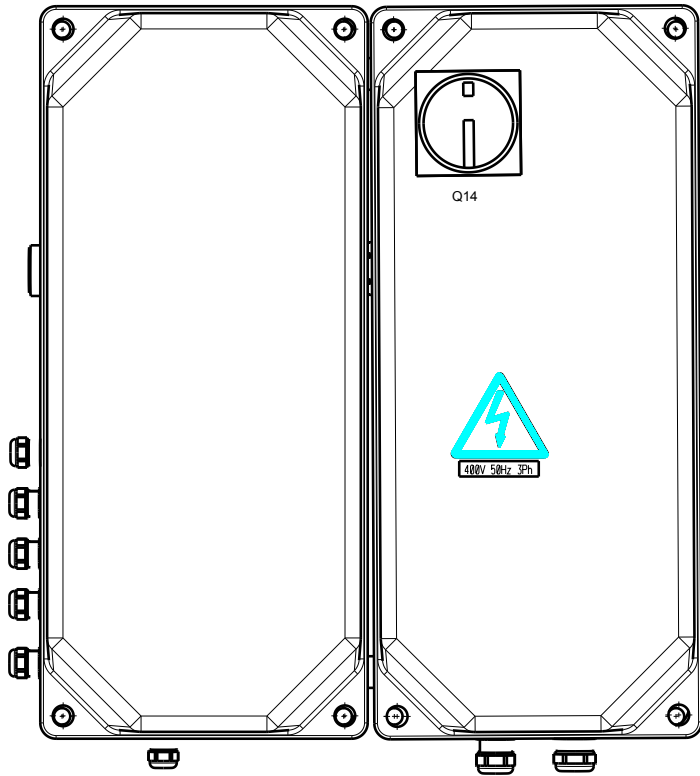

Tarare il salvamotore a 8A  
 Set the overload cut-out at 8A

 ENGINEERING and MARKETING S.P.A.	LISTA DEI COMPONENTI - LIST OF COMPONENTS - TEILELISTE LISTE DES PIÈCES DÉTACHÉES - LISTA DE PIEZAS		SCHEMA ELETTRICO 1/18 ELECTRICAL SCHEME 1/18 SCHALTPLAN 1/18 SCHEMA ELECTRIQUE 1/18 ESQUEMA ELECTRICO 1/18	Pag. 51 di 88
	Tavola N°C - Rev. 1	752205562		NAV43.15 - NAV63.15



# TOPOGRAFICO SCHEDA RICEVENTE 18962

## RECEIVING CARD 18962 TOPOGRAPHIC VIEW

Valido nella versione con manipolatore Bluetooth  
 Valid for Bluetooth handle control version  
 Gültig für Version mit Bluetooth-Manipulator  
 Valide dans la version avec manipulateur Bluetooth  
 Válido en la versión con manipulador Bluetooth

Valido nella variante 230V 50Hz 3Ph  
 Valid for 230V 50Hz 3Ph version  
 Gültig für 230V 50Hz 3Ph Version  
 Valide en la version 230V 50Hz 3Ph  
 Válido en la versión 230V 50Hz 3Ph

Valido nella variante 230V 60Hz 3Ph  
 Valid for 230V 60Hz 3Ph version  
 Gültig für 230V 60Hz 3Ph Version  
 Valide en la version 230V 60Hz 3Ph  
 Válido en la versión 230V 60Hz 3Ph

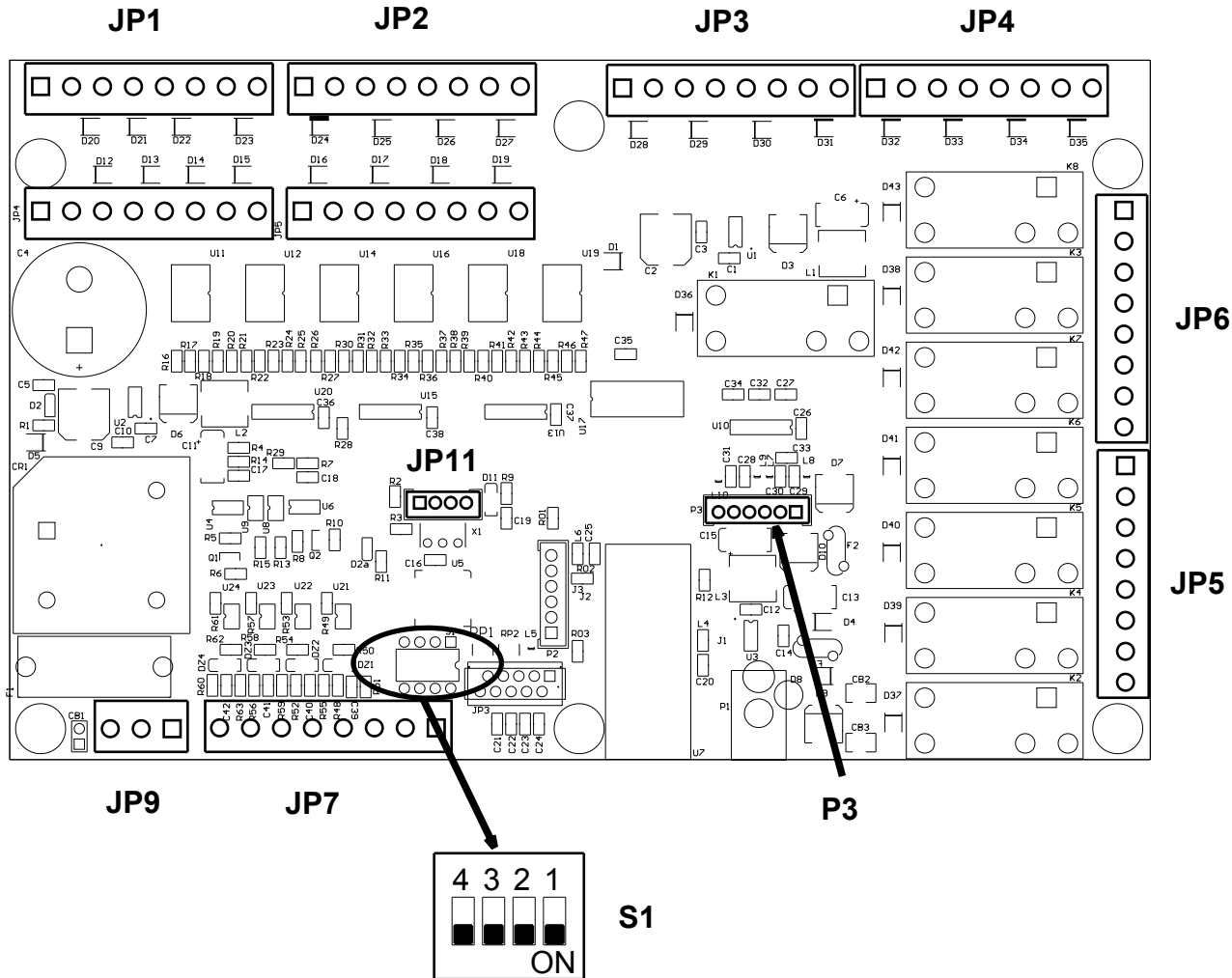

# IN/OUT SCHEDA RICEVENTE 18962

Valido nella versione con manipolatore Bluetooth  
Valid for Bluetooth handle control version  
Gültig für Version mit Bluetooth-Manipulator  
Valide dans la version avec manipulateur Bluetooth  
Válido en la versión con manipulador Bluetooth

PIN JP1	NUMERO	FUNZIONE
1	JP1-1	Q1 INDIETRO CARRO UTENSILE
2	JP1-2	0V per Q1
3	JP1-3	Q2 AVANTI CARRO UTENSILE
4	JP1-4	0V per Q2
5	JP1-5	Q3 AVANTI CARRO MANDRINO
6	JP1-6	0V per Q3
7	JP1-7	Q4 INDIETRO CARRO MANDRINO
8	JP1-8	0V per Q4

PIN JP2	NUMERO	FUNZIONE
1	JP2-1	Q5 CHIUSURA MANDRINO
2	JP2-2	0V per Q5
3	JP2-3	Q6 APERTURA MANDRINO
4	JP2-4	0V per Q6
5	JP2-5	Q7 DISCESA BRACCIO MANDRINO Q14 LENTO DISCESA MANDRINO
6	JP2-6	0V per Q7 0V per Q14
7	JP2-7	Q8 SALITA BRACCIO MANDRINO
8	JP2-8	0V per Q8

PIN JP3	NUMERO	FUNZIONE
1	JP3-1	Q9 ROTAZ.ANTIORARIA UTENSILE
2	JP3-2	0V per Q9
3	JP3-3	Q10 ROTAZ.ORARIA UTENSILE
4	JP3-4	0V per Q10
5	JP3-5	Q11 DISCESA BRACCIO UTENSILE
6	JP3-6	0V per Q11
7	JP3-7	Q12 SALITA BRACCIO UTENSILE
8	JP3-8	0V pe Q12

PIN JP4	NUMERO	FUNZIONE
1	JP4-1	Q13 RICIRCOLO OLIO
2	JP4-2	0V per Q13
3	JP4-3	N.U.
4	JP4-4	N.U.
5	JP4-5	N.U.
6	JP4-6	N.U.
7	JP4-7	N.U.
8	JP4-8	N.U.

PIN JP5	NUMERO	FUNZIONE
1	JP5-1	N.U.
2	JP5-2	N.U.
3	JP5-3	0 Vac
4	JP5-4	KM5 COMANDO ROTAZ. 2V CENTRALINA OLEOD
5	JP5-5	KM4 COMANDO MOTORE CENTRALINA A STELLA 2V
6	JP5-6	KM3 COMANDO ROTAZ. 1V CENTRALINA OLEOD
7	JP5-7	KM2 COMANDO ROTAZ. ORARIA MANDRINO
8	JP5-8	KM1 COMANDO ROTAZ. ANTIORARIA MANDRINO

PIN JP7	NUMERO	FUNZIONE
1	JP7-1	COLLEGATO A JP7-2
2	JP7-2	COLLEGATO A JP7-1
3	JP7-3	N.U.
4	JP7-4	N.U.
5	JP7-5	N.U.
6	JP7-6	N.U.
7	JP7-7	N.U.
8	JP7-8	N.U.

PIN JP9	NUMERO	FUNZIONE
1	JP9-1	0 Vac
2	JP9-2	N.U.
3	JP9-3	19 Vac

Valido nella variante 230V 50Hz 3Ph  
Valid for 230V 50Hz 3Ph version  
Gültig für 230V 50Hz 3Ph Version  
Valide en la version 230V 50Hz 3Ph  
Válido en la versión 230V 50Hz 3Ph

Valido nella variante 230V 60Hz 3Ph  
Valid for 230V 60Hz 3Ph version  
Gültig für 230V 60Hz 3Ph Version  
Valide en la version 230V 60Hz 3Ph  
Válido en la versión 230V 60Hz 3Ph

# RECEIVING CARD 18962 IN/OUT

Valido nella versione con manipolatore Bluetooth  
Valid for Bluetooth handle control version  
Gültig für Version mit Bluetooth-Manipulator  
Valide dans la version avec manipulateur Bluetooth  
Válido en la versión con manipulador Bluetooth

Valido nella variante 230V 50Hz 3Ph  
Valid for 230V 50Hz 3Ph version  
Gültig für 230V 50Hz 3Ph Version  
Valide en la version 230V 50Hz 3Ph  
Válido en la versión 230V 50Hz 3Ph

Valido nella variante 230V 60Hz 3Ph  
Valid for 230V 60Hz 3Ph version  
Gültig für 230V 60Hz 3Ph Version  
Valide en la version 230V 60Hz 3Ph  
Válido en la versión 230V 60Hz 3Ph

PIN JP1	NUMBER	FUNCTION
1	JP1-1	Q1 TOOL CARRIAGE BACKWARD
2	JP1-2	0V for Q1
3	JP1-3	Q2 TOOL CARRIAGE FORWARD
4	JP1-4	0V for Q2
5	JP1-5	Q3 CHUCK CARRIAGE FORWARD
6	JP1-6	0V for Q3
7	JP1-7	Q4 CHUCK CARRIAGE BACKWARD
8	JP1-8	0V for Q4

PIN JP2	NUMBER	FUNCTION
1	JP2-1	Q5 CHUCK CLOSING
2	JP2-2	0V for Q5
3	JP2-3	Q6 CHUCK OPENING
4	JP2-4	0V for Q6
5	JP2-5	Q7 CHUCK ARM DESCENT Q14 CHUCK SLOW DESCENT
6	JP2-6	0V for Q7 0V for Q14
7	JP2-7	Q8 CHUCK ARM RISE
8	JP2-8	0V for Q8

PIN JP3	NUMBER	FUNCTION
1	JP3-1	Q9 TOOL COUNTERCLOCKWISE ROT.
2	JP3-2	0V for Q9
3	JP3-3	Q10 TOOL CLOCKWISE ROTATION
4	JP3-4	0V for Q10
5	JP3-5	Q11 TOOL ARM DESCENT
6	JP3-6	0V for Q11
7	JP3-7	Q12 TOOL ARM RISE
8	JP3-8	0V for Q12

PIN JP4	NUMBER	FUNCTION
1	JP4-1	Q13 OIL RECIRCULATION
2	JP4-2	0V for Q13
3	JP4-3	N.U.
4	JP4-4	N.U.
5	JP4-5	N.U.
6	JP4-6	N.U.
7	JP4-7	N.U.
8	JP4-8	N.U.

PIN JP5	NUMBER	FUNCTION
1	JP5-1	N.U.
2	JP5-2	N.U.
3	JP5-3	0 Vac
4	JP5-4	KM5 2V HYDR. POWER UNIT ROTATION CONTROL
5	JP5-5	KM4 2V STAR TYPE HYDR. POWER UNIT MOTOR ROT. CONTR.
6	JP5-6	KM3 1V HYDRAULIC POWER UNIT ROT. CONTROL
7	JP5-7	KM2 CHUCK CLOCKWISE ROTATION CONTROL
8	JP5-8	KM1 CHUCK COUNTERCLOCKWISE ROT. CONTROL

PIN JP7	NUMBER	FUNCTION
1	JP7-1	CONNECTED TO JP7-2
2	JP7-2	CONNECTED TO JP7-1
3	JP7-3	N.U.
4	JP7-4	N.U.
5	JP7-5	N.U.
6	JP7-6	N.U.
7	JP7-7	N.U.
8	JP7-8	N.U.

PIN JP9	NUMBER	FUNCTION
1	JP9-1	0 Vac
2	JP9-2	N.U.
3	JP9-3	19 Vac

# SCHEMA CIRCUITI QUADRO ELETTRICO (RICEVITORE) ELECTRICAL PANEL (RECEIVER) CIRCUITS DIAGRAM

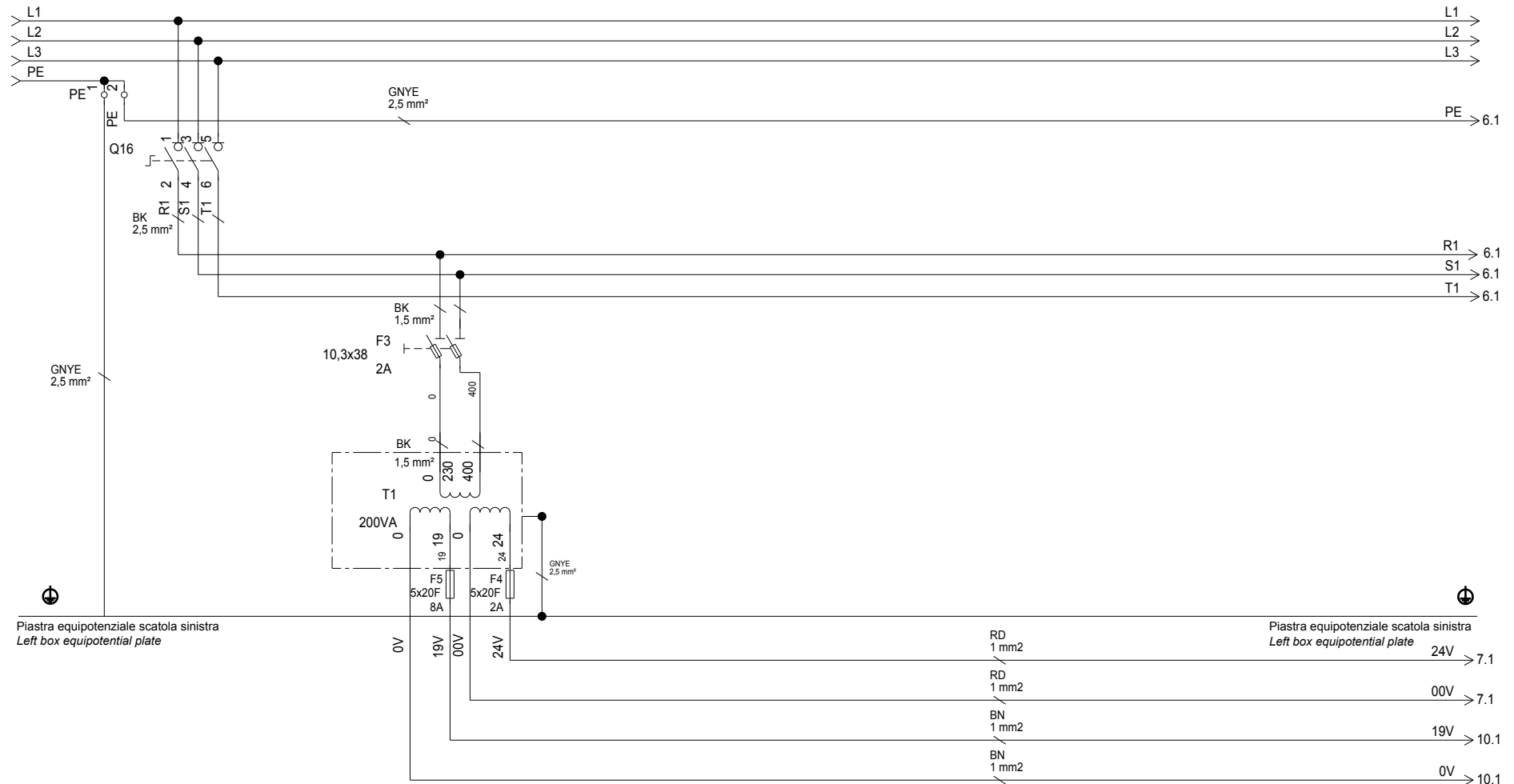

Valido nella versione con manipolatore Bluetooth  
Valid for Bluetooth handle control version  
Gültig für Version mit Bluetooth-Manipulator  
Valide dans la version avec manipulateur Bluetooth  
Válido en la versión con manipulador Bluetooth

Valido nella variante 230V 50Hz 3Ph  
Valid for 230V 50Hz 3Ph version  
Gültig für 230V 50Hz 3Ph Version  
Valide en la version 230V 50Hz 3Ph  
Válido en la versión 230V 50Hz 3Ph

Valido nella variante 230V 60Hz 3Ph  
Valid for 230V 60Hz 3Ph version  
Gültig für 230V 60Hz 3Ph Version  
Valide en la version 230V 60Hz 3Ph  
Válido en la versión 230V 60Hz 3Ph

 <b>ENGINEERING and MARKETING S.P.A.</b>	<b>LISTA DEI COMPONENTI - LIST OF COMPONENTS - TEILELISTE</b> <b>LISTE DES PIECES DETACHEES - LISTA DE PIEZAS</b>		SCHEMA ELETTRICO 5/18 ELECTRICAL SCHEME 5/18 SCHALTPLAN 5/18 SCHEMA ELECTRIQUE 5/18 ESQUEMA ELECTRICO 5/18	<b>Pag. 55 di 88</b>
	<b>Tavola N°C - Rev. 1</b>	<b>752205562</b>		<b>NAV43.15 - NAV63.15</b>

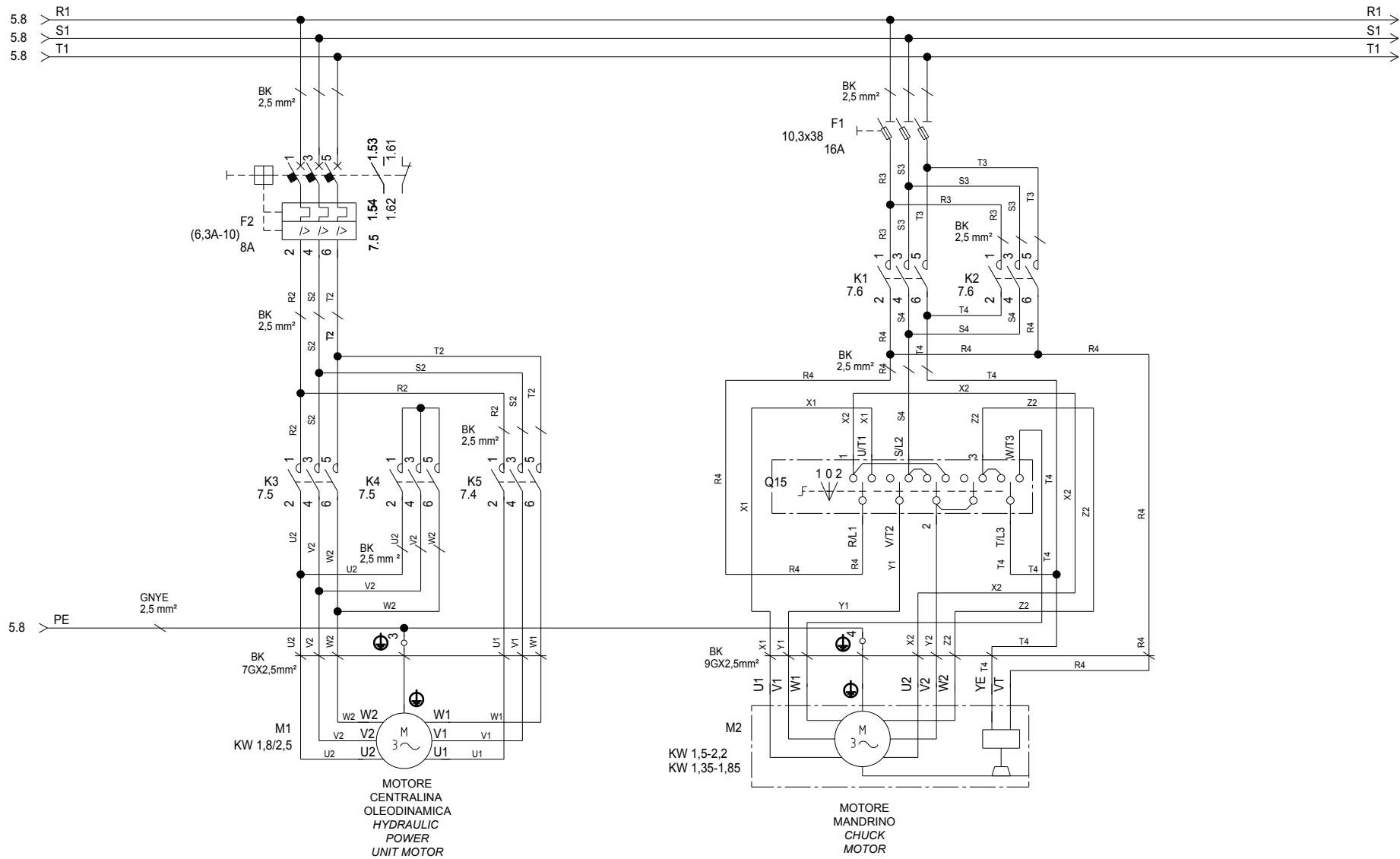

Valido nella versione con manipolatore Bluetooth  
 Valid for Bluetooth handle control version  
 Gültig für Version mit Bluetooth-Manipulator  
 Valide dans la version avec manipulateur Bluetooth  
 Válido en la versión con manipulador Bluetooth

Valido nella variante 230V 50Hz 3Ph  
 Valid for 230V 50Hz 3Ph version  
 Gültig für 230V 50Hz 3Ph Version  
 Valide en la version 230V 50Hz 3Ph  
 Válido en la versión 230V 50Hz 3Ph

Valido nella variante 230V 60Hz 3Ph  
 Valid for 230V 60Hz 3Ph version  
 Gültig für 230V 60Hz 3Ph Version  
 Valide en la version 230V 60Hz 3Ph  
 Válido en la versión 230V 60Hz 3Ph

5.8 > 24V  
5.8 > 00V

Valido nella versione con manipolatore Bluetooth  
Valid for Bluetooth handle control version  
Gültig für Version mit Bluetooth-Manipulator  
Valide dans la version avec manipulateur Bluetooth  
Válido en la versión con manipulador Bluetooth

Valido nella variante 230V 50Hz 3Ph  
Valid for 230V 50Hz 3Ph version  
Gültig für 230V 50Hz 3Ph Version  
Valide en la version 230V 50Hz 3Ph  
Válido en la versión 230V 50Hz 3Ph

Valido nella variante 230V 60Hz 3Ph  
Valid for 230V 60Hz 3Ph version  
Gültig für 230V 60Hz 3Ph Version  
Valide en la version 230V 60Hz 3Ph  
Válido en la versión 230V 60Hz 3Ph

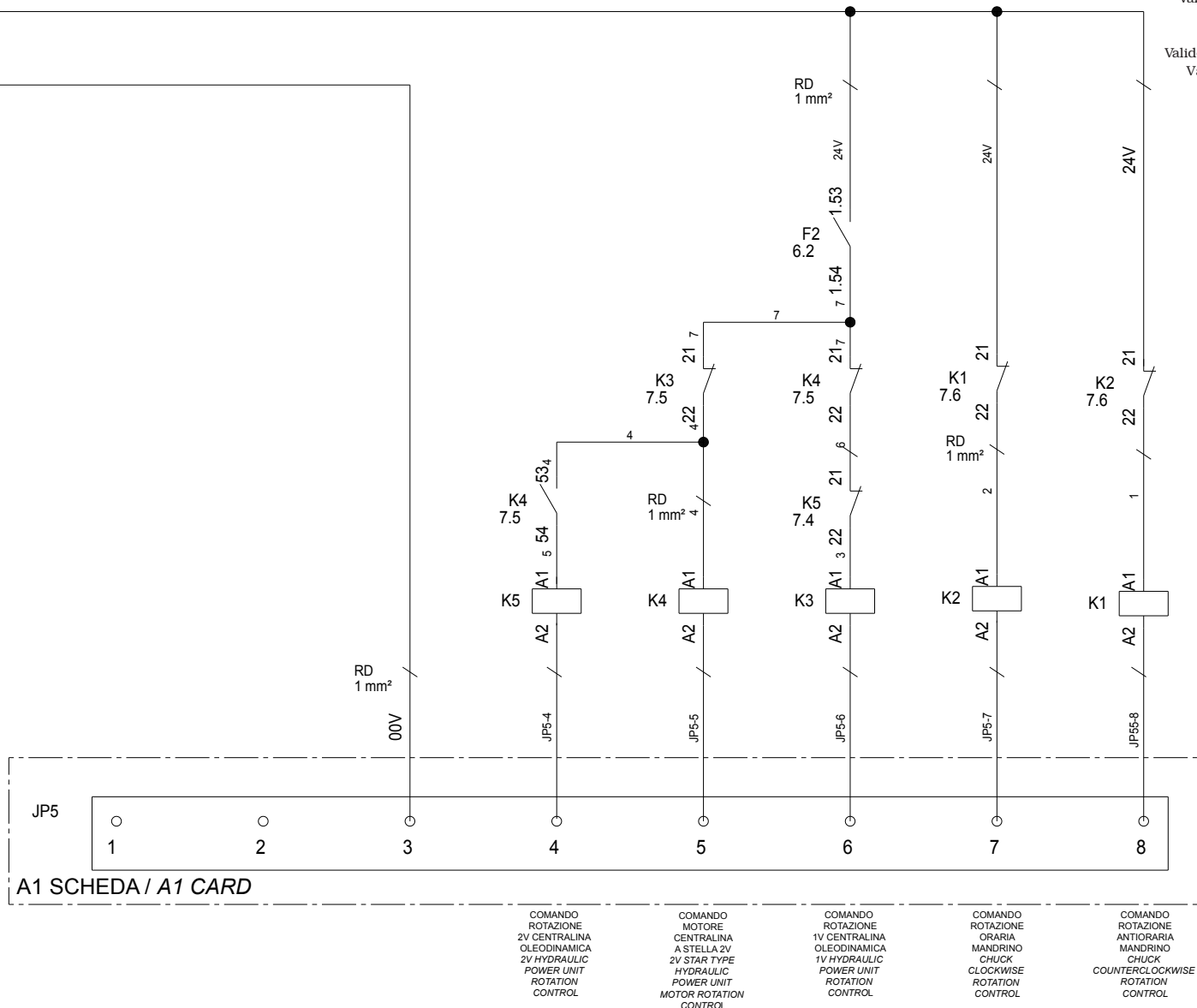

A1 SCHEDA / A1 CARD

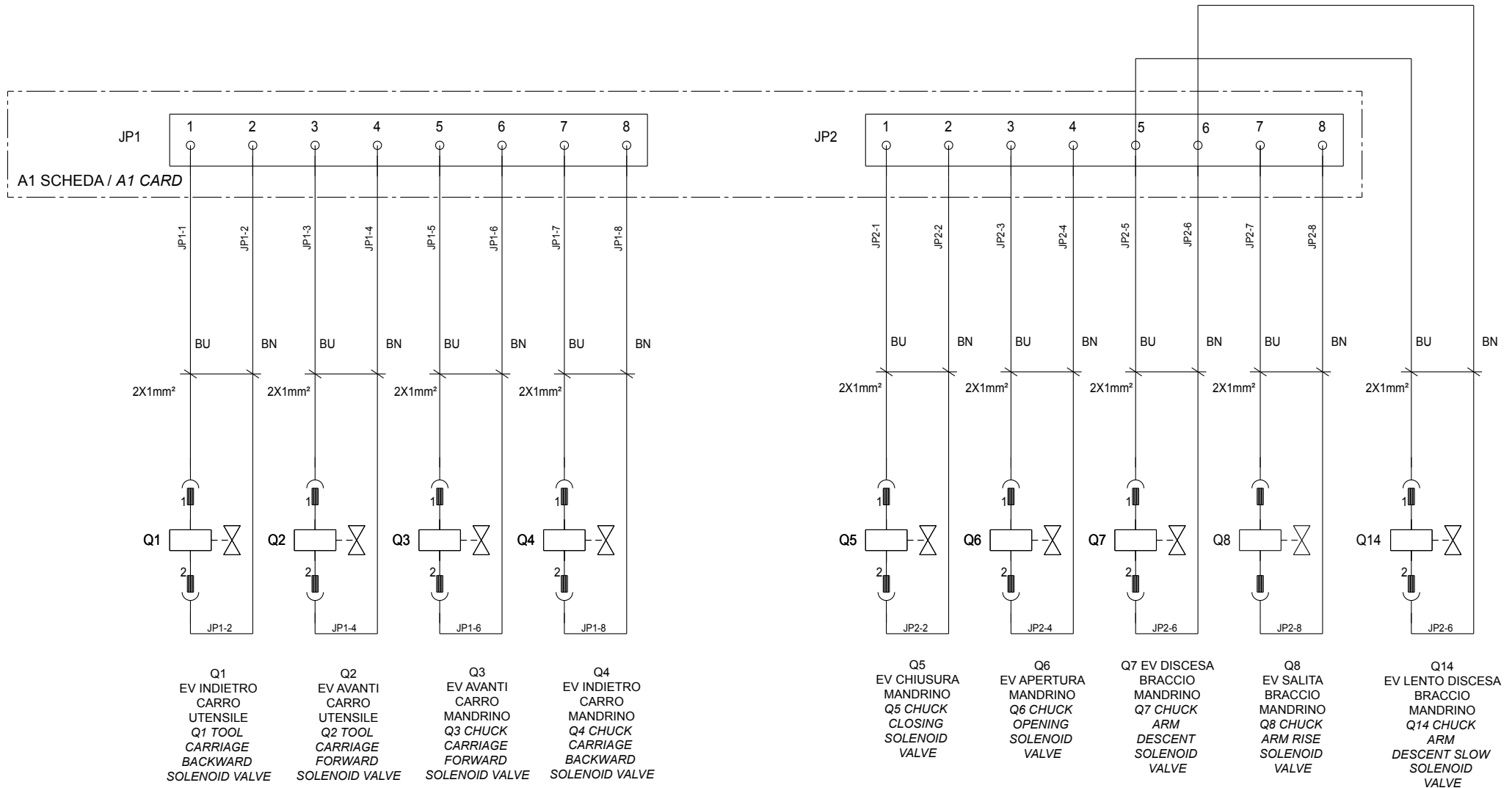

Valido nella versione con manipolatore Bluetooth  
Valid for Bluetooth handle control version  
Gültig für Version mit Bluetooth-Manipulator  
Valide dans la version avec manipulateur Bluetooth  
Válido en la versión con manipulador Bluetooth

Valido nella variante 230V 50Hz 3Ph  
Valid for 230V 50Hz 3Ph version  
Gültig für 230V 50Hz 3Ph Version  
Valide en la version 230V 50Hz 3Ph  
Válido en la versión 230V 50Hz 3Ph

Valido nella variante 230V 60Hz 3Ph  
Valid for 230V 60Hz 3Ph version  
Gültig für 230V 60Hz 3Ph Version  
Valide en la version 230V 60Hz 3Ph  
Válido en la versión 230V 60Hz 3Ph

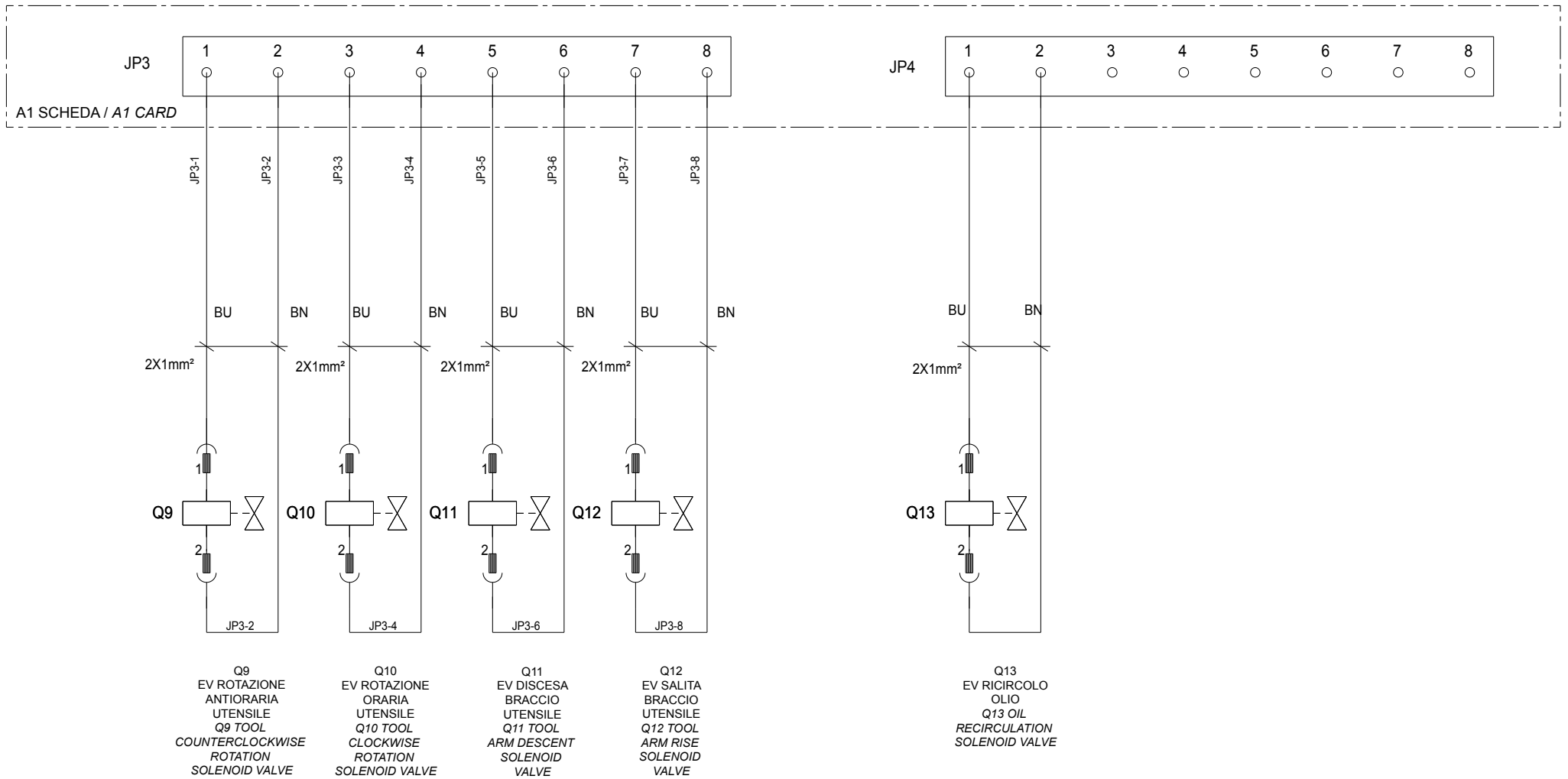

Valido nella versione con manipolatore Bluetooth  
Valid for Bluetooth handle control version  
Gültig für Version mit Bluetooth-Manipulator  
Valide dans la version avec manipulateur Bluetooth  
Válido en la versión con manipulador Bluetooth

Valido nella variante 230V 50Hz 3Ph  
Valid for 230V 50Hz 3Ph version  
Gültig für 230V 50Hz 3Ph Version  
Valide en la version 230V 50Hz 3Ph  
Válido en la versión 230V 50Hz 3Ph

Valido nella variante 230V 60Hz 3Ph  
Valid for 230V 60Hz 3Ph version  
Gültig für 230V 60Hz 3Ph Version  
Valide en la version 230V 60Hz 3Ph  
Válido en la versión 230V 60Hz 3Ph



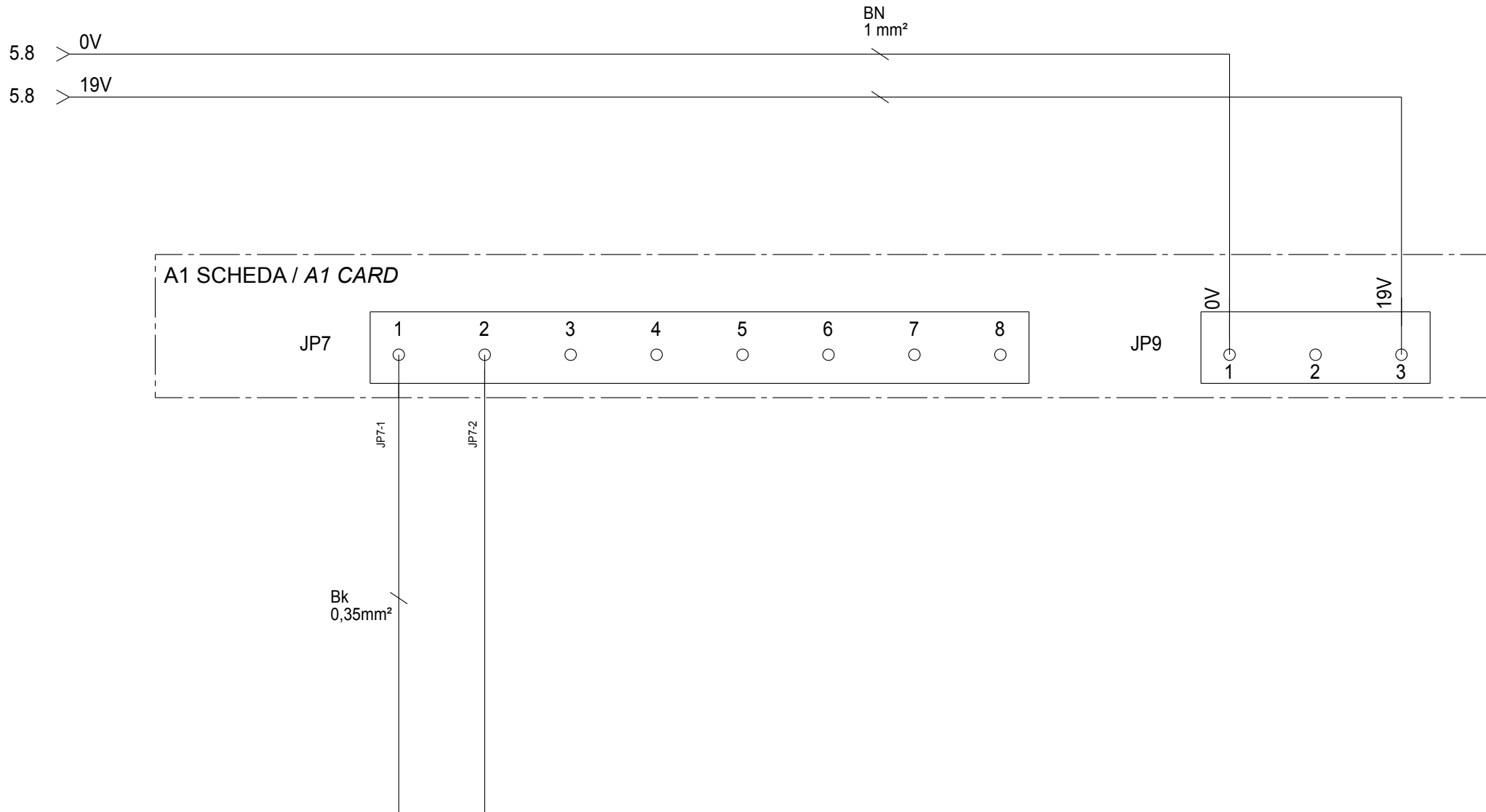

Valido nella versione con manipolatore Bluetooth  
 Valid for Bluetooth handle control version  
 Gültig für Version mit Bluetooth-Manipulator  
 Valide dans la version avec manipulateur Bluetooth  
 Válido en la versión con manipulador Bluetooth

Valido nella variante 230V 50Hz 3Ph  
 Valid for 230V 50Hz 3Ph version  
 Gültig für 230V 50Hz 3Ph Version  
 Valide en la version 230V 50Hz 3Ph  
 Válido en la versión 230V 50Hz 3Ph

Valido nella variante 230V 60Hz 3Ph  
 Valid for 230V 60Hz 3Ph version  
 Gültig für 230V 60Hz 3Ph Version  
 Valide en la version 230V 60Hz 3Ph  
 Válido en la versión 230V 60Hz 3Ph

 <b>Butler</b> ENGINEERING and MARKETING S.P.A.	<b>LISTA DEI COMPONENTI - LIST OF COMPONENTS - TEILELISTE</b> <b>LISTE DES PIECES DETACHEES - LISTA DE PIEZAS</b>		SCHEMA ELETTRICO 10/18 ELECTRICAL SCHEME 10/18 SCHALTPLAN 10/18 SCHEMA ELECTRIQUE 10/18 ESQUEMA ELECTRICO 10/18	<b>Pag. 60 di 88</b>
	<b>Tavola N°C - Rev. 1</b>	<b>752205562</b>		<b>NAV43.15 - NAV63.15</b>

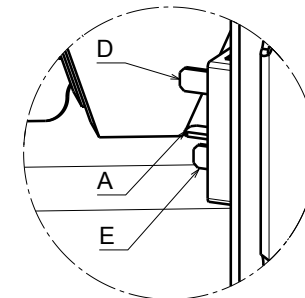
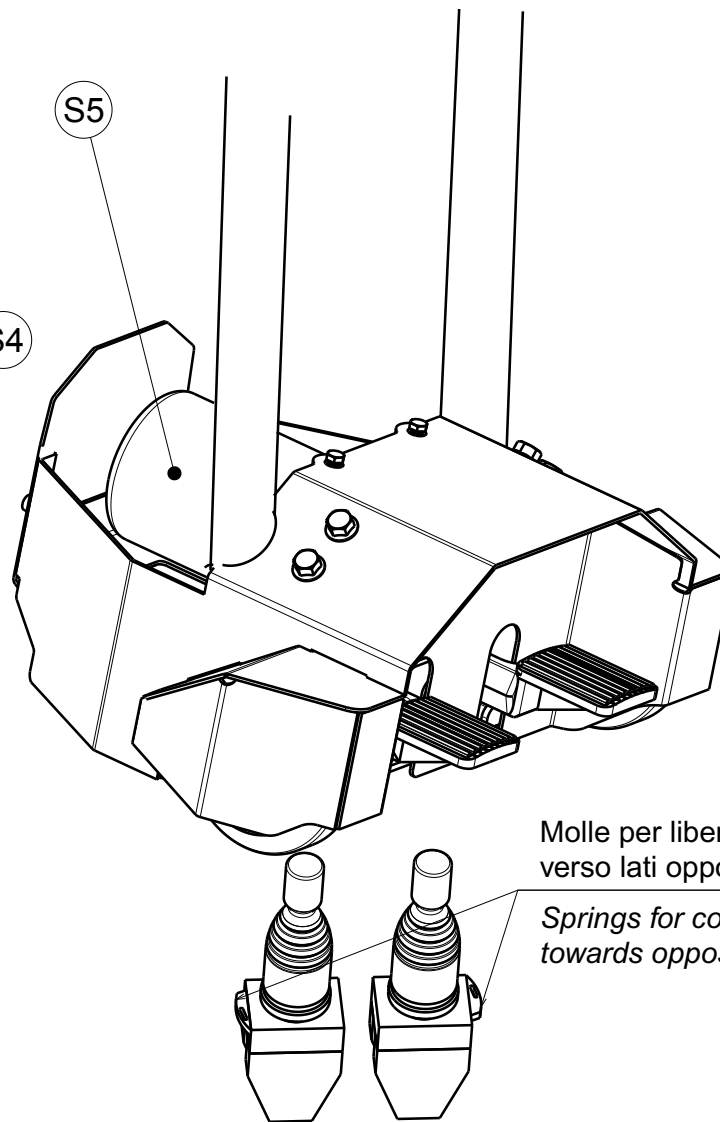
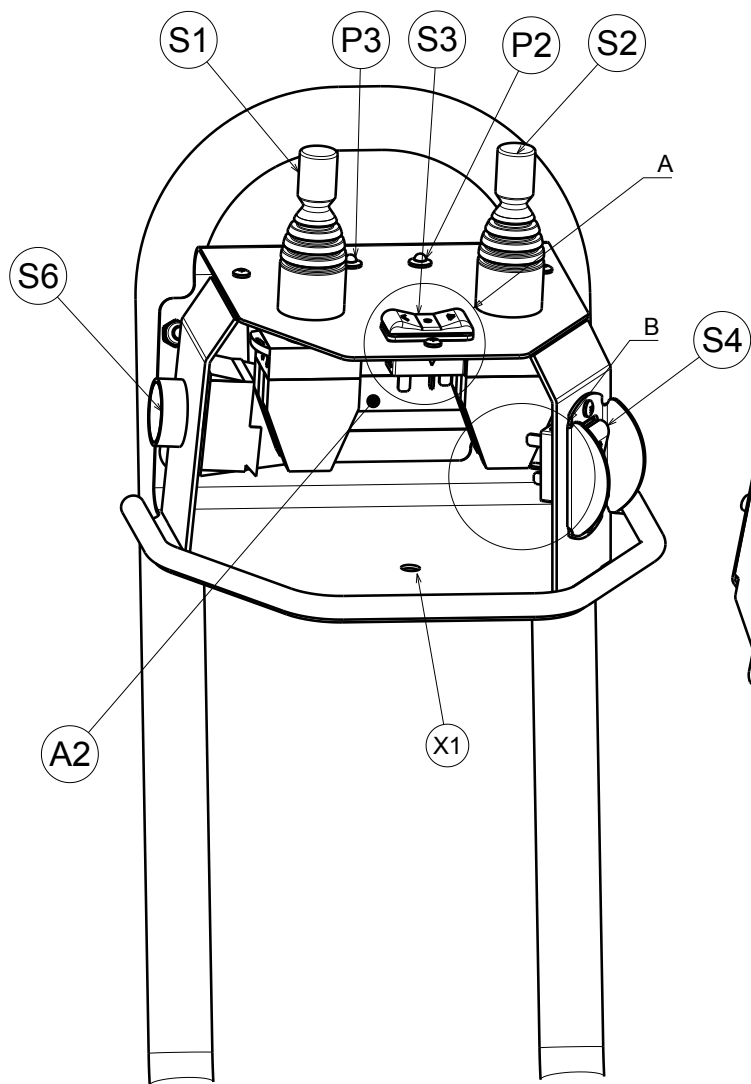

Dettaglio B  
Detail B

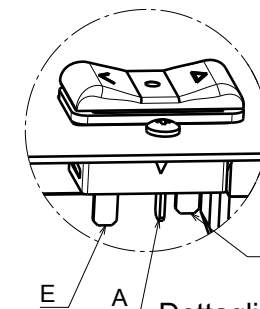

Dettaglio A  
Detail A

Valido nella versione con manipolatore Bluetooth  
Valid for Bluetooth handle control version  
Gültig für Version mit Bluetooth-Manipulator  
Valide dans la version avec manipulateur Bluetooth  
Válido en la versión con manipulador Bluetooth

Valido nella variante 230V 50Hz 3Ph  
Valid for 230V 50Hz 3Ph version  
Gültig für 230V 50Hz 3Ph Version  
Valide en la version 230V 50Hz 3Ph  
Válido en la versión 230V 50Hz 3Ph

Valido nella variante 230V 60Hz 3Ph  
Valid for 230V 60Hz 3Ph version  
Gültig für 230V 60Hz 3Ph Version  
Valide en la version 230V 60Hz 3Ph  
Válido en la versión 230V 60Hz 3Ph

Valido nella versione con manipolatore Bluetooth  
 Valid for Bluetooth handle control version  
 Gültig für Version mit Bluetooth-Manipulator  
 Valide dans la version avec manipulateur Bluetooth  
 Válido en la versión con manipulador Bluetooth

# TOPOGRAFICO SCHEDA TRASMETTENTE 18961 TRANSMITTING CARD 18961 TOPOGRAPHIC VIEW

Valido nella variante 230V 50Hz 3Ph  
 Valid for 230V 50Hz 3Ph version  
 Gültig für 230V 50Hz 3Ph Version  
 Valide en la version 230V 50Hz 3Ph  
 Válido en la versión 230V 50Hz 3Ph

Valido nella variante 230V 60Hz 3Ph  
 Valid for 230V 60Hz 3Ph version  
 Gültig für 230V 60Hz 3Ph Version  
 Valide en la version 230V 60Hz 3Ph  
 Válido en la versión 230V 60Hz 3Ph

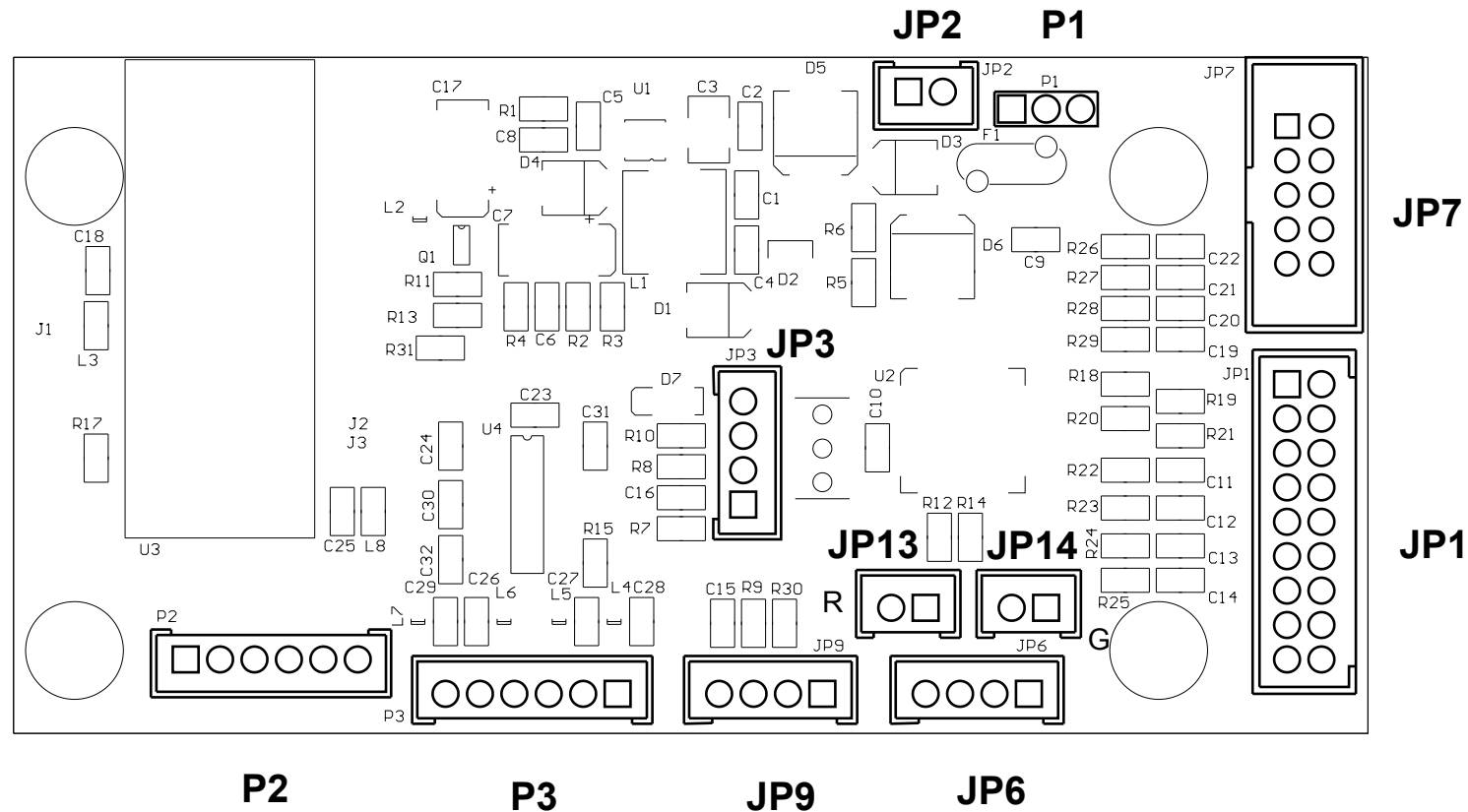

# IN/OUT SCHEDA TRASMITTENTE 18961

PIN JP1	NUMERO	FUNZIONE
1	JP1-1	S1 INDIETRO CARRO MANDRINO
2	JP1-2	S2 INDIETRO CARRO UTENSILE
3	JP1-3	S1 AVANTI CARRO MANDRINO
4	JP1-4	S2 AVANTI CARRO UTENSILE
5	JP1-5	S1 SALITA BRACCIO MANDRINO
6	JP1-6	S2 DISCESA BRACCIO UTENSILE
7	JP1-7	S1 DISCESA BRACCIO MANDRINO
8	JP1-8	S2 SALITA BRACCIO UTENSILE
9	JP1-9	S1 (COMUNE)
10	JP1-10	S2 (COMUNE)
11	JP1-11	S4 (COMUNE)
12	JP1-12	N.U.
13	JP1-13	S4 PULSANTE CHIUSURA MANDRINO
14	JP1-14	N.U.
15	JP1-15	S4 PULSANTE APERTURA MANDRINO
16	JP1-16	N.U.
17	JP1-17	S3 PULS.ROTAZ.ANTIOR. UTENS.
18	JP1-18	N.U.

P1	NUMERO	FUNZIONE
X1		0-12Vdc

PIN JP9	NUMERO	FUNZIONE
1	JP9-1	S6 PULS. DOPPIA VELOC. CENTR.
2	JP9-2	N.U.
3	JP9-3	S3 (COMUNE)
4	JP9-4	S6 PULS. DOPPIA VELOC. CENTR.

PIN JP13	NUMERO	FUNZIONE
1	JP13-1	P2 LED ROSSO +
2	JP13-2	P2 LED ROSSO -

PIN JP14	NUMERO	FUNZIONE
1	JP14-1	P3 LED VERDE +
2	JP14-2	P3 LED VERDE -

PIN JP6	NUMERO	FUNZIONE
1	JP6-1	S5 SELETT.ROTAZ.ANTIOR. MANDRINO
2	JP6-2	S5 SELETT. ROTAZ.ORARIA MANDRINO
3	JP6-3	S3 PULS.ROTAZ.ORARIA UTENSILE
4	JP6-4	S5 COMUNE

PIN JP2	NUMERO	FUNZIONE
1	JP2-1	G2 BATTERIA -
2	JP2-2	G2 BATTERIA +

Valido nella versione con manipolatore Bluetooth  
Valid for Bluetooth handle control version  
Gültig für Version mit Bluetooth-Manipulator  
Valide dans la version avec manipulateur Bluetooth  
Válido en la versión con manipulador Bluetooth

Valido nella variante 230V 50Hz 3Ph  
Valid for 230V 50Hz 3Ph version  
Gültig für 230V 50Hz 3Ph Version  
Valide en la version 230V 50Hz 3Ph  
Válido en la versión 230V 50Hz 3Ph

Valido nella variante 230V 60Hz 3Ph  
Valid for 230V 60Hz 3Ph version  
Gültig für 230V 60Hz 3Ph Version  
Valide en la version 230V 60Hz 3Ph  
Válido en la versión 230V 60Hz 3Ph

# TRANSMITTING CARD 18961 IN/OUT

PIN JP1	NUMBER	FUNCTION
1	JP1-1	S1 CHUCK CARRIAGE BACKWARD
2	JP1-2	S2 TOOL CARRIAGE BACKWARD
3	JP1-3	S1 CHUCK CARRIAGE FORWARD
4	JP1-4	S2 TOOL CARRIAGE FORWARD
5	JP1-5	S1 CHUCK ARM RISE
6	JP1-6	S2 TOOL ARM DESCENT
7	JP1-7	S1 CHUCK ARM DESCENT
8	JP1-8	S2 TOOL ARM RISE
9	JP1-9	S1 (COMMON)
10	JP1-10	S2 (COMMON)
11	JP1-11	S4 (COMMON)
12	JP1-12	N.U.
13	JP1-13	S4 CHUCK CLOSING PUSHBUTTON
14	JP1-14	N.U.
15	JP1-15	S4 CHUCK OPENING PUSHBUTTON
16	JP1-16	N.U.
17	JP1-17	S3 TOOL COUNTERCLOCKWISE ROT. PUSHBUTTON
18	JP1-18	N.U.

P1	NUMBER	FUNCTION
X1		0-12Vdc

PIN JP9	NUMBER	FUNCTION
1	JP9-1	S6 HYDR. POWER UNIT DOUBLE SPEED PUSHBUTTON
2	JP9-2	N.U.
3	JP9-3	S3 (COMMON)
4	JP9-4	S6 HYDR. POWER UNIT DOUBLE SPEED PUSHBUTTON

PIN JP13	NUMBER	FUNCTION
1	JP13-1	P2 RED LED +
2	JP13-2	P2 RED LED -

PIN JP14	NUMBER	FUNCTION
1	JP14-1	P3 GREEN LED +
2	JP14-2	P3 GREEN LED -

PIN JP6	NUMBER	FUNCTION
1	JP6-1	S5 CHUCK COUNTERCLOCKWISE ROT. SELECTOR
2	JP6-2	S5 CHUCK CLOCKWISE ROT. SELECTOR
3	JP6-3	S3 TOOL CLOCKWISE ROT. PUSHBUTTON
4	JP6-4	S5 COMMON

PIN JP2	NUMBER	FUNCTION
1	JP2-1	G2 BATTERY -
2	JP2-2	G2 BATTERY +

Valido nella versione con manipolatore Bluetooth  
Valid for Bluetooth handle control version  
Gültig für Version mit Bluetooth-Manipulator  
Valide dans la version avec manipulateur Bluetooth  
Válido en la versión con manipulador Bluetooth

Valido nella variante 230V 50Hz 3Ph  
Valid for 230V 50Hz 3Ph version  
Gültig für 230V 50Hz 3Ph Version  
Valide en la version 230V 50Hz 3Ph  
Válido en la versión 230V 50Hz 3Ph

Valido nella variante 230V 60Hz 3Ph  
Valid for 230V 60Hz 3Ph version  
Gültig für 230V 60Hz 3Ph Version  
Valide en la version 230V 60Hz 3Ph  
Válido en la versión 230V 60Hz 3Ph

# SCHEMA CIRCUITI MANIPOLATORE A TERRA (TRASMETTITORE) GROUND HANDLE CONTROL (TRANSMITTER) CIRCUITS DIAGRAM

Valido nella versione con manipolatore Bluetooth  
Valid for Bluetooth handle control version  
Gültig für Version mit Bluetooth-Manipulator  
Valide dans la version avec manipulateur Bluetooth  
Válido en la versión con manipulador Bluetooth

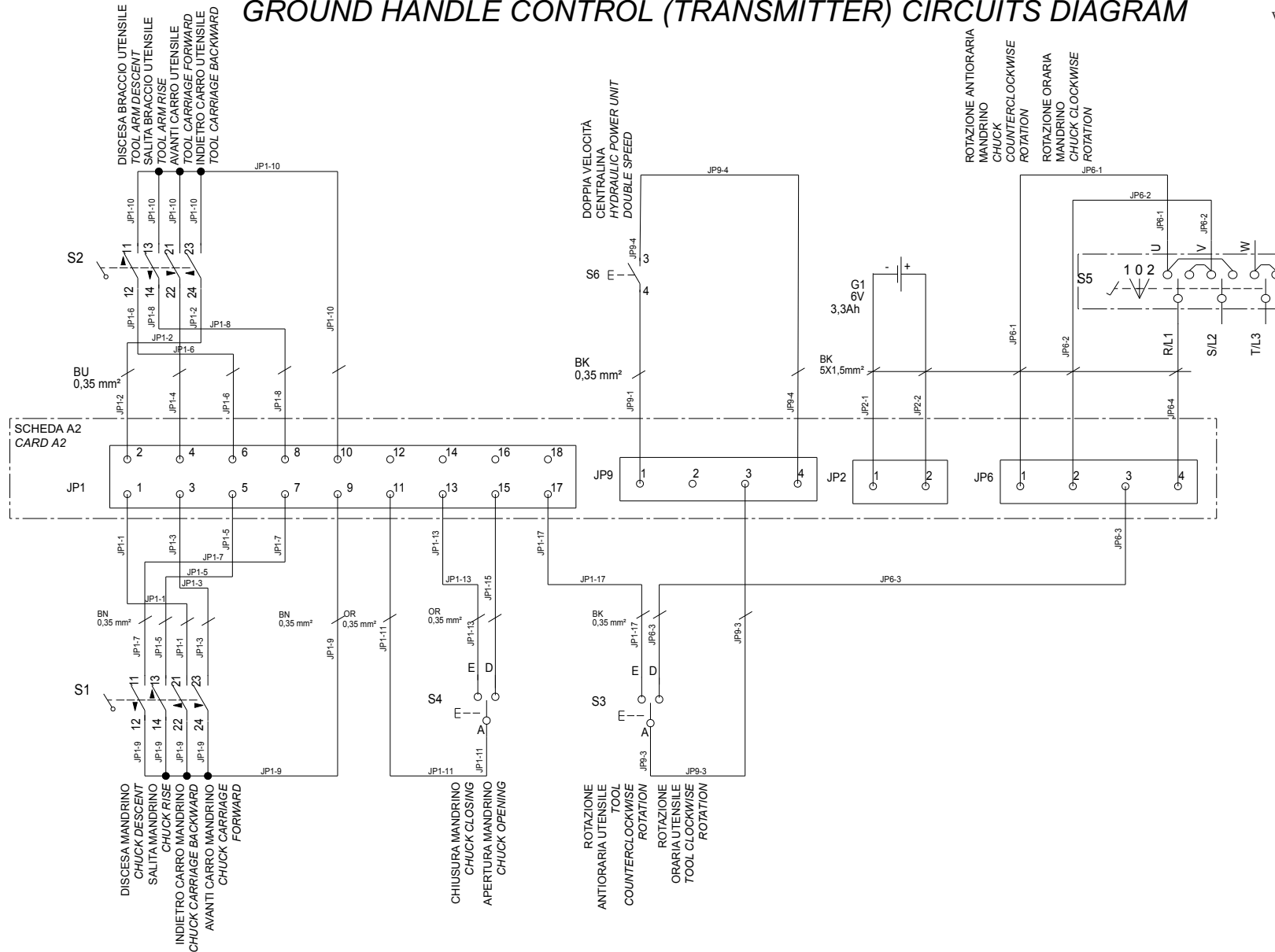

Valido nella variante 230V 50Hz 3Ph  
Valid for 230V 50Hz 3Ph version  
Gültig für 230V 50Hz 3Ph Version  
Valide en la version 230V 50Hz 3Ph  
Válido en la versión 230V 50Hz 3Ph

Valido nella variante 230V 60Hz 3Ph  
Valid for 230V 60Hz 3Ph version  
Gültig für 230V 60Hz 3Ph Version  
Valide en la version 230V 60Hz 3Ph  
Válido en la versión 230V 60Hz 3Ph

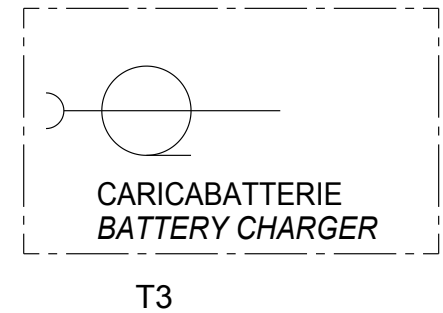
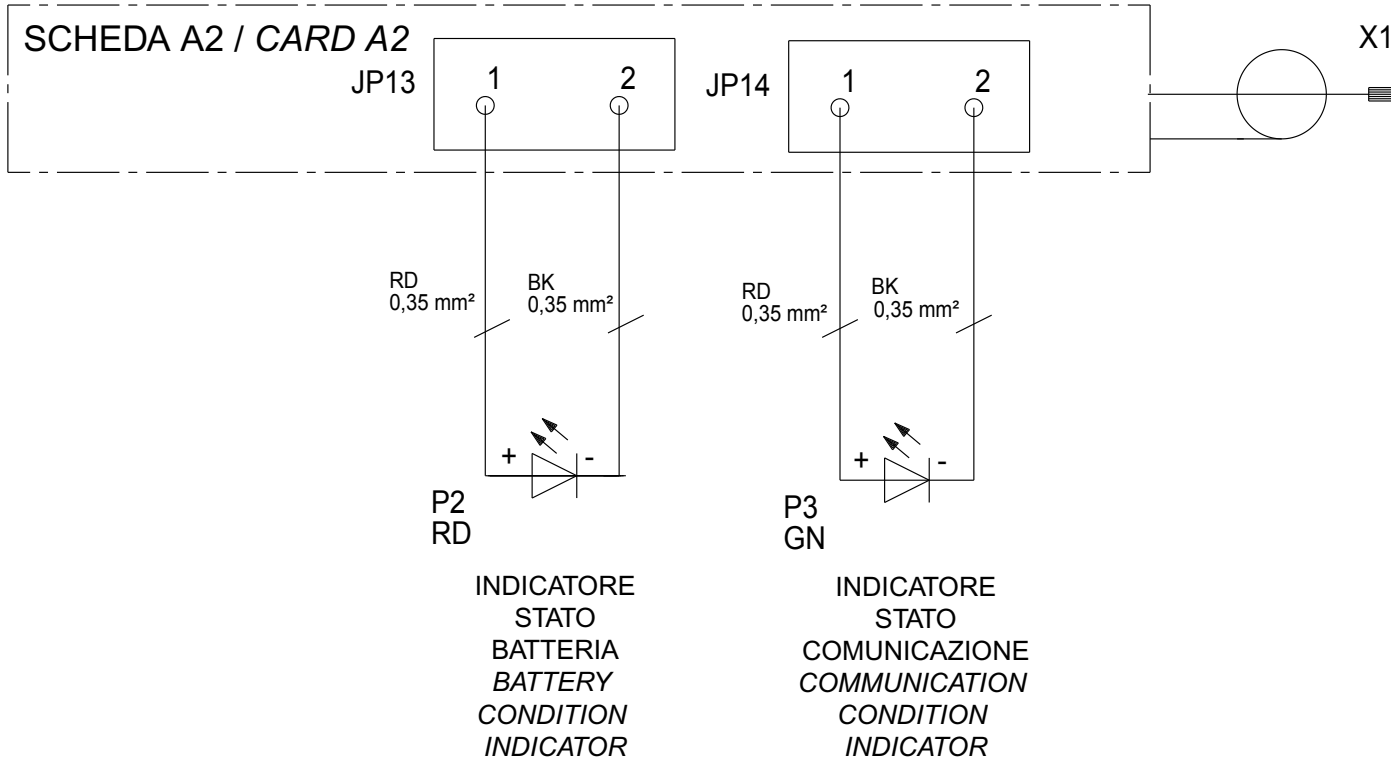

Valido nella versione con manipolatore Bluetooth  
 Valid for Bluetooth handle control version  
 Gültig für Version mit Bluetooth-Manipulator  
 Valide dans la version avec manipulateur Bluetooth  
 Válido en la versión con manipulador Bluetooth

Valido nella variante 230V 50Hz 3Ph  
 Valid for 230V 50Hz 3Ph version  
 Gültig für 230V 50Hz 3Ph Version  
 Valide en la version 230V 50Hz 3Ph  
 Válido en la versión 230V 50Hz 3Ph

Valido nella variante 230V 60Hz 3Ph  
 Valid for 230V 60Hz 3Ph version  
 Gültig für 230V 60Hz 3Ph Version  
 Valide en la version 230V 60Hz 3Ph  
 Válido en la versión 230V 60Hz 3Ph

# LISTA COMPONENTI

Valido nella versione con manipolatore Bluetooth  
Valid for Bluetooth handle control version  
Gültig für Version mit Bluetooth-Manipulator  
Valide dans la version avec manipulateur Bluetooth  
Válido en la versión con manipulador Bluetooth

RIFERIMENTO	DESCRIZIONE	DATI TECNICI	SIGLA CATALOGO	QUANTITA	RIFERIMENTO DOCUMENTO
A1	SCHEDA ELETT. RICEVENTE	-	18962	1	2.5
A2	SCHEDA ELETT. TRASMITTENTE	-	18961	1	11.2
F1	PORTAFUSIBILE	3 POLI SEZIONABILE 10,3x38 32A 690V	515025	1	6.6
	FUSIBILE	10,3x38 16A 500V aM RITARDATO	507045	3	
F2	INTERRUTTORE AUTOM. TRIPOLARE	6,3-10A AC3 400V 2,2KW	518277	1	6.2
	CONTATTI AUSILIARI	1NO+1NC ATTACCO FRONTALE	518279	1	6.2
F3	PORTAFUSIBILE	2 POLI SEZIONABILE 10,3x38 32A 690V	515027	1	5.3
	FUSIBILE	10,3X38 2A 500V RAPIDO	507019	2	
F4	FUSIBILE	5x20F 250V 2A RAPIDO	507043	1	5.3
F5	FUSIBILE	5x20F 250V 8A RAPIDO	507090	1	5.3
F6	FUSIBILE	5X20 T 8A 250V	507118	1	5.7
G1	BATTERIA	6V 3,3AH/20HR Lead	10066	1	14.6
K1	CONTATTORE TRIPOLARE	9A AC3 400V 4,2KW 1NC 24Vac 50/60Hz	522137	1	7.6
K2	CONTATTORE TRIPOLARE	9A AC3 400V 4,2KW 1NC 24Vac 50/60Hz	522137	1	7.6
K3	CONTATTORE TRIPOLARE	9A AC3 400V 4,2KW 1NC 24Vac 50/60Hz	522137	1	7.5
K4	CONTATTORE TRIPOLARE	9A AC3 400V 4,2KW 1NC 24Vac 50/60Hz	522137	1	7.5
	CONTATTI AUSILIARI	1NO+1NC ATTACCO FRONTALE	522147	1	7.4
K5	CONTATTORE	9A AC3 400V 4,2KW 1NC 24Vac 50/60Hz	522137	1	7.4
P2	INDICATORE LUMINOSO (LED)	ROSSO	18065	1	15.4
P3	INDICATORE LUMINOSO (LED)	VERDE	18066	1	15.5
Q1...Q14	ELETTROVALVOLE	-	-	14	8-9
Q16	SEZIONATORE TRIPOLARE	1th 32A Ui 690V-50Hz Uimp 4KW	518223+518226	1	5.2
Q15	COMMUTATORE DI POLI DAHLANDER	25A 500V	518189	1	6.5-6.6
S1	MANIPOLATORE	4 POS.+CENTR.TEMPORANEE Ø22	517157AS	1	14.2
S2	MANIPOLATORE	4 POS.+CENTR.TEMPORANEE Ø22	517157AS	1	14.2
S3	PULSANTE BASCULANTE	-	517283	1	14.5
S4	PULSANTE BASCULANTE	-	517283	1	14.4
S5	COMMUTATORE	1th 25A Ui 690V-50Hz Uimp 4KW	518058	1	14.7-14.8
S6	PULSANTE	-	517105AS	1	14.5
T1	TRASFORMATORE	200 VA 50/60 Hz PRI: 0/230/400V SEC: 0/19V 8,95A 0/24V 1,25A	528056	1	5.3
-	-	-	-	-	-
T3	CARICABATTERIA	21.6W 7.2V 3A Lithium ion	18064	1	15.6
M1	MOTORE CENTRALINA NAV63.15 NAV43.15	1,85/2,5KW 400V 50HZ 4,9/7,7A cosØ=0,73/0,70 1400/2800 rpm	900003880	1	6.3
M2	MOTORE MANDRINO NAV43.15	1,35/1,85KW 400V 50Hz 1400/2800rpm AUTOFR.	900003840		
M2	MOTORE MANDRINO NAV63.15	1,5/2,2KW 400V 50Hz 4,2/6A cosØ=0,80/0,84 1400/2800rpm AUTOFR.	900003810	1	6.5

Valido nella variante 230V 50Hz 3Ph  
Valid for 230V 50Hz 3Ph version  
Gültig für 230V 50Hz 3Ph Version  
Valide en la version 230V 50Hz 3Ph  
Válido en la versión 230V 50Hz 3Ph

Valido nella variante 230V 60Hz 3Ph  
Valid for 230V 60Hz 3Ph version  
Gültig für 230V 60Hz 3Ph Version  
Valide en la version 230V 60Hz 3Ph  
Válido en la versión 230V 60Hz 3Ph



# COMPONENTS LIST

Valido nella versione con manipolatore Bluetooth  
Valid for Bluetooth handle control version  
Gültig für Version mit Bluetooth-Manipulator  
Valide dans la version avec manipulateur Bluetooth  
Válido en la versión con manipulador Bluetooth

REFERENCE	DESCRIPTION	TECHNICAL SPECIFICATIONS	ABBREVIATION ON CATALOGUE	QUANTITY	DOCUMENT REFERENCE
A1	RECEIVING ELECTRICAL CARD	-	18962	1	2.5
A2	TRANSMITTING ELECTRICAL CARD	-	18961	1	11.2
F1	FUSE HOLDER	10,3x38 32A 690V SECTIONABLE 3 POLES	515025	1	6.6
	FUSE	10,3x38 16A 500V aM DELAYED-ACTION	507045	3	
F2	TRIPOLAR AUTOMATIC SWITCH	6,3-10A AC3 400V 2,2KW	518277	1	6.2
	AUXILIARY CONTACTS	1NO+1NC FRONT COUPLING	518279	1	6.2
F3	FUSE HOLDER	10,3x38 32A 690V SECTIONABLE 2 POLES	515027	1	5.3
	FUSE	10,3X38 2A 500V RAPID	507019	2	
F4	FUSE	5x20F 250V 2A RAPID	507043	1	5.3
F5	FUSE	5x20F 250V 8A RAPID	507090	1	5.3
F6	FUSE	5X20 T 8A 250V	507118	1	5.7
G1	BATTERY	6V 3,3AH/20HR Lead	10066	1	14.6
K1	TRIPOLAR CONTACTOR	9A AC3 400V 4,2KW 1NC 24Vac 50/60Hz	522137	1	7.6
K2	TRIPOLAR CONTACTOR	9A AC3 400V 4,2KW 1NC 24Vac 50/60Hz	522137	1	7.6
K3	TRIPOLAR CONTACTOR	9A AC3 400V 4,2KW 1NC 24Vac 50/60Hz	522137	1	7.5
K4	TRIPOLAR CONTACTOR	9A AC3 400V 4,2KW 1NC 24Vac 50/60Hz	522137	1	7.5
	AUXILIARY CONTACTS	1NO+1NC FRONT COUPLING	522147	1	7.4
K5	CONTACTOR	9A AC3 400V 4,2KW 1NC 24Vac 50/60Hz	522137	1	7.4
P2	BACKLIGHTED INDICATOR (LED)	RED	18065	1	15.4
P3	BACKLIGHTED INDICATOR (LED)	GREEN	18066	1	15.5
Q1...Q14	SOLENOID VALVES	-	-	14	8-9
Q16	TRIPOLAR KNIFE SWITCH	1th 32A Ui 690V-50Hz Uimp 4KW	518223 + 518226	1	5.2
Q15	DAHLANDER POLES COMMUTATOR	25A 500V	518189	1	6.5-6.6
S1	HANDLE CONTROL	4 POS.+ CENTRAL POS. TEMPORARY Ø22	517157AS	1	14.2
S2	HANDLE CONTROL	4 POS.+ CENTRAL POS. TEMPORARY Ø22	517157AS	1	14.2
S3	BALANCING PUSHBUTTON	-	517283	1	14.5
S4	BALANCING PUSHBUTTON	-	517283	1	14.4
S5	COMMUTATOR	1th 25A Ui 690V-50Hz Uimp 4KW	518058	1	14.7-14.8
S6	PUSHBUTTON	-	517105AS	1	14.5
T1	TRANSFORMER	200 VA 50/60 Hz PRI: 0/230/400V SEC: 0/19V 8,95A 0/24V 1,25A	528056	1	5.3
-	-	-	-	-	-
T3	BATTERY CHARGER	21.6W 7.2V 3A Lithium ion	18064	1	15.6
M1	HYDRAULIC POWER UNIT MOTOR	1,85/2,5KW 400V 50HZ 4,9/7,7A cosØ=0,73/0,70 1400/2800 rpm	900003880	1	6.3
M2	CHUCK MOTOR	1,35/1,85KW 400V 50Hz 1400/2800rpm SELF BRAKING	900003840	1	
M2	CHUCK MOTOR	1,5/2,2KW 400V 50Hz 4,2/6A cosØ=0,80/0,84 1400/2800rpm SELF BRAKING	900003810	1	6.5

Valido nella variante 230V 50Hz 3Ph  
Valid for 230V 50Hz 3Ph version  
Gültig für 230V 50Hz 3Ph Version  
Valide en la version 230V 50Hz 3Ph  
Válido en la versión 230V 50Hz 3Ph

Valido nella variante 230V 60Hz 3Ph  
Valid for 230V 60Hz 3Ph version  
Gültig für 230V 60Hz 3Ph Version  
Valide en la version 230V 60Hz 3Ph  
Válido en la versión 230V 60Hz 3Ph

Valido nella variante 500V 50Hz 3Ph  
 Valid for 500V 50Hz 3Ph version  
 Gültig für 500V 50Hz 3Ph Version  
 Valide en la version 500V 50Hz 3Ph  
 Válido en la versión 500V 50Hz 3Ph

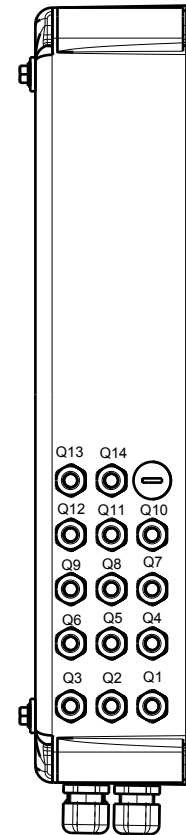
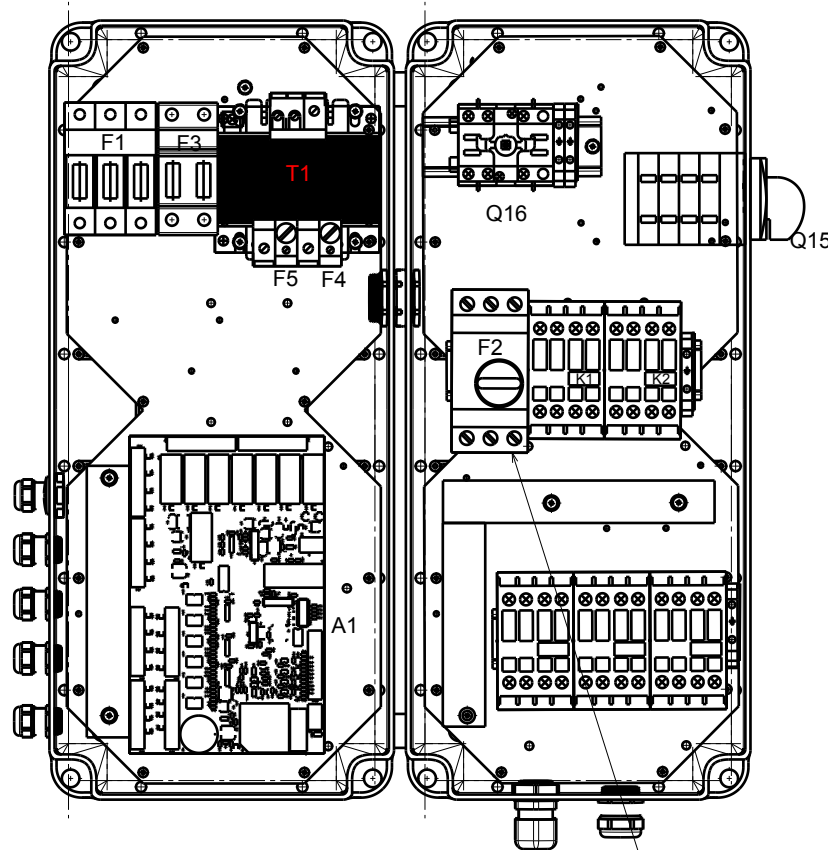
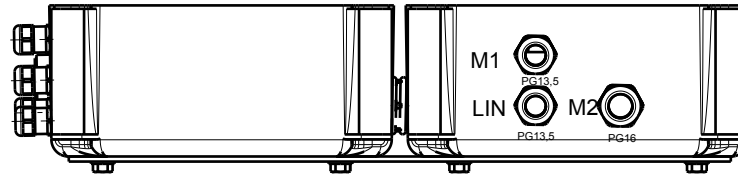
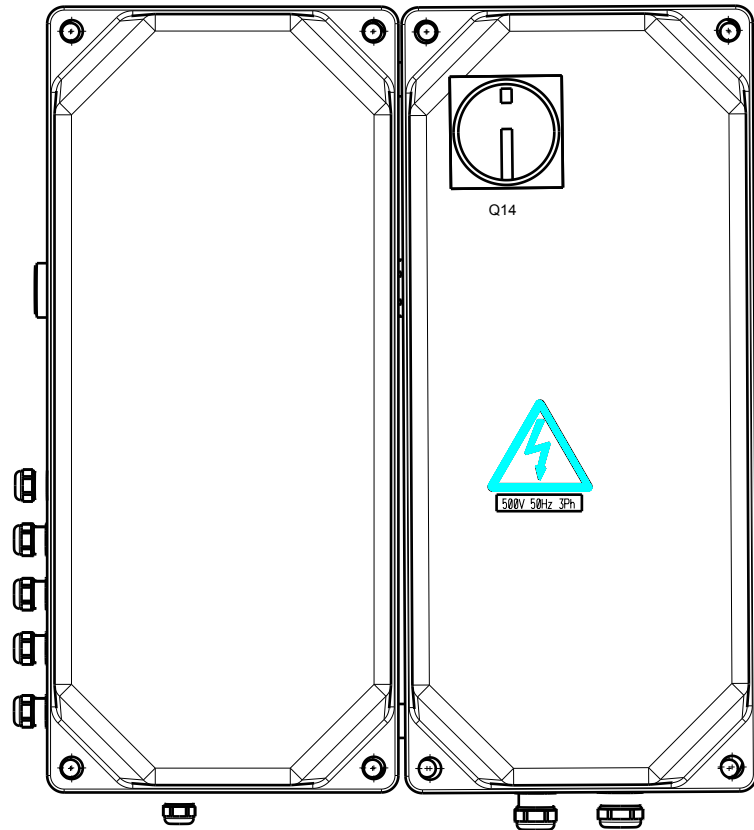

Tarare il salvamotore a 8A  
 Set the overload cut-out at 8A

# TOPOGRAFICO SCHEDA RICEVENTE 18962

## RECEIVING CARD 18962 TOPOGRAPHIC VIEW

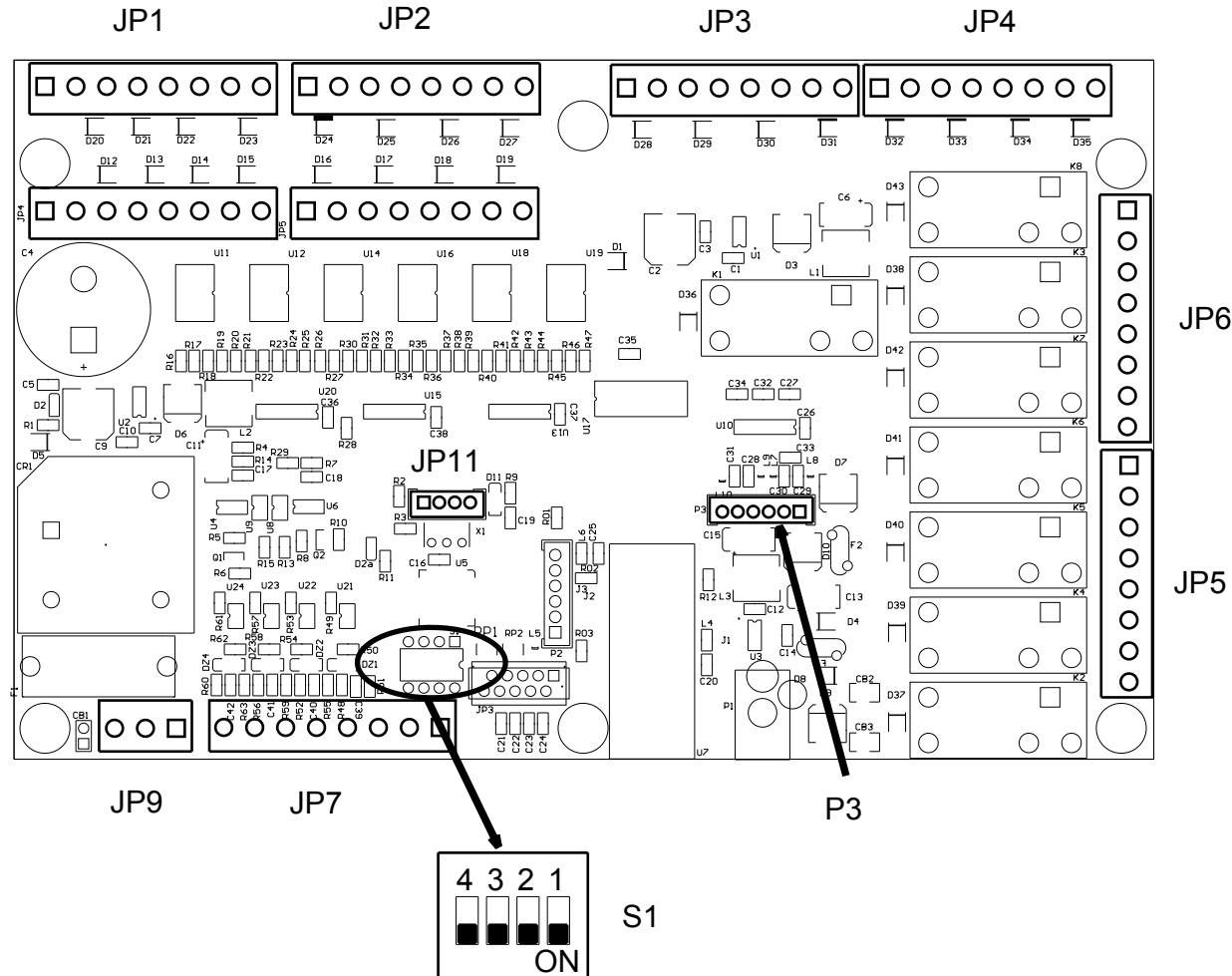

# IN/OUT SCHEDA RICEVENTE 18962

Valido nella variante 500V 50Hz 3Ph  
Valid for 500V 50Hz 3Ph version  
Gültig für 500V 50Hz 3Ph Version  
Valide en la version 500V 50Hz 3Ph  
Válido en la versión 500V 50Hz 3Ph

PIN JP1	NUMERO	FUNZIONE
1	JP1-1	Q1 INDIETRO CARRO UTENSILE
2	JP1-2	0V per Q1
3	JP1-3	Q2 AVANTI CARRO UTENSILE
4	JP1-4	0V per Q2
5	JP1-5	Q3 AVANTI CARRO MANDRINO
6	JP1-6	0V per Q3
7	JP1-7	Q4 INDIETRO CARRO MANDRINO
8	JP1-8	0V per Q4

PIN JP2	NUMERO	FUNZIONE
1	JP2-1	Q5 CHIUSURA MANDRINO
2	JP2-2	0V per Q5
3	JP2-3	Q6 APERTURA MANDRINO
4	JP2-4	0V per Q6
5	JP2-5	Q7 DISCESA BRACCIO MANDRINO Q14 LENTO DISCESA MANDRINO
6	JP2-6	0V per Q7 0V per Q14
7	JP2-7	Q8 SALITA BRACCIO MANDRINO
8	JP2-8	0V per Q8

PIN JP3	NUMERO	FUNZIONE
1	JP3-1	Q9 ROTAZ.ANTIORARIA UTENSILE
2	JP3-2	0V per Q9
3	JP3-3	Q10 ROTAZ.ORARIA UTENSILE
4	JP3-4	0V per Q10
5	JP3-5	Q11 DISCESA BRACCIO UTENSILE
6	JP3-6	0V per Q11
7	JP3-7	Q12 SALITA BRACCIO UTENSILE
8	JP3-8	0V per Q12

PIN JP4	NUMERO	FUNZIONE
1	JP4-1	Q13 RICIRCOLO OLIO
2	JP4-2	0V per Q13
3	JP4-3	N.U.
4	JP4-4	N.U.
5	JP4-5	N.U.
6	JP4-6	N.U.
7	JP4-7	N.U.
8	JP4-8	N.U.

PIN JP5	NUMERO	FUNZIONE
1	JP5-1	N.U.
2	JP5-2	N.U.
3	JP5-3	0 Vac
4	JP5-4	KM5 COMANDO ROTAZ. 2V CENTRALINA OLEOD
5	JP5-5	KM4 COMANDO MOTORE CENTRALINA A STELLA 2V
6	JP5-6	KM3 COMANDO ROTAZ. 1V CENTRALINA OLEOD
7	JP5-7	KM2 COMANDO ROTAZ. ORARIA MANDRINO
8	JP5-8	KM1 COMANDO ROTAZ. ANTIORARIA MANDRINO

PIN JP7	NUMERO	FUNZIONE
1	JP7-1	COLLEGATO A JP7-2
2	JP7-2	COLLEGATO A JP7-1
3	JP7-3	N.U.
4	JP7-4	N.U.
5	JP7-5	N.U.
6	JP7-6	N.U.
7	JP7-7	N.U.
8	JP7-8	N.U.

PIN JP9	NUMERO	FUNZIONE
1	JP9-1	0 Vac
2	JP9-2	N.U.
3	JP9-3	19 Vac

# RECEIVING CARD 18962 IN/OUT

Valido nella variante 500V 50Hz 3Ph  
Valid for 500V 50Hz 3Ph version  
Gültig für 500V 50Hz 3Ph Version  
Valide en la version 500V 50Hz 3Ph  
Válido en la versión 500V 50Hz 3Ph

PIN JP1	NUMBER	FUNCTION
1	JP1-1	Q1 TOOL CARRIAGE BACKWARD
2	JP1-2	0V for Q1
3	JP1-3	Q2 TOOL CARRIAGE FORWARD
4	JP1-4	0V for Q2
5	JP1-5	Q3 CHUCK CARRIAGE FORWARD
6	JP1-6	0V for Q3
7	JP1-7	Q4 CHUCK CARRIAGE BACKWARD
8	JP1-8	0V for Q4

PIN JP2	NUMBER	FUNCTION
1	JP2-1	Q5 CHUCK CLOSING
2	JP2-2	0V for Q5
3	JP2-3	Q6 CHUCK OPENING
4	JP2-4	0V for Q6
5	JP2-5	Q7 CHUCK ARM DESCENT Q14 CHUCK SLOW DESCENT
6	JP2-6	0V for Q7 0V for Q14
7	JP2-7	Q8 CHUCK ARM RISE
8	JP2-8	0V for Q8

PIN JP3	NUMBER	FUNCTION
1	JP3-1	Q9 TOOL COUNTERCLOCKWISE ROT.
2	JP3-2	0V for Q9
3	JP3-3	Q10 TOOL CLOCKWISE ROTATION
4	JP3-4	0V for Q10
5	JP3-5	Q11 TOOL ARM DESCENT
6	JP3-6	0V for Q11
7	JP3-7	Q12 TOOL ARM RISE
8	JP3-8	0V for Q12

PIN JP4	NUMBER	FUNCTION
1	JP4-1	Q13 OIL RECIRCULATION
2	JP4-2	0V for Q13
3	JP4-3	N.U.
4	JP4-4	N.U.
5	JP4-5	N.U.
6	JP4-6	N.U.
7	JP4-7	N.U.
8	JP4-8	N.U.

PIN JP5	NUMBER	FUNCTION
1	JP5-1	N.U.
2	JP5-2	N.U.
3	JP5-3	0 Vac
4	JP5-4	KM5 2V HYDR. POWER UNIT ROTATION CONTROL
5	JP5-5	KM4 2V STAR TYPE HYDR. POWER UNIT MOTOR ROT. CONTR.
6	JP5-6	KM3 1V HYDRAULIC POWER UNIT ROT. CONTROL
7	JP5-7	KM2 CHUCK CLOCKWISE ROTATION CONTROL
8	JP5-8	KM1 CHUCK COUNTERCLOCKWISE ROT. CONTROL

PIN JP7	NUMBER	FUNCTION
1	JP7-1	CONNECTED TO JP7-2
2	JP7-2	CONNECTED TO JP7-1
3	JP7-3	N.U.
4	JP7-4	N.U.
5	JP7-5	N.U.
6	JP7-6	N.U.
7	JP7-7	N.U.
8	JP7-8	N.U.

PIN JP9	NUMBER	FUNCTION
1	JP9-1	0 Vac
2	JP9-2	N.U.
3	JP9-3	19 Vac

# SCHEMA CIRCUITI QUADRO ELETTRICO (RICEVITORE) ELECTRICAL PANEL (RECEIVER) CIRCUITS DIAGRAM

Valido nella variante 500V 50Hz 3Ph  
Valid for 500V 50Hz 3Ph version  
Gültig für 500V 50Hz 3Ph Version  
Valide en la version 500V 50Hz 3Ph  
Válido en la versión 500V 50Hz 3Ph

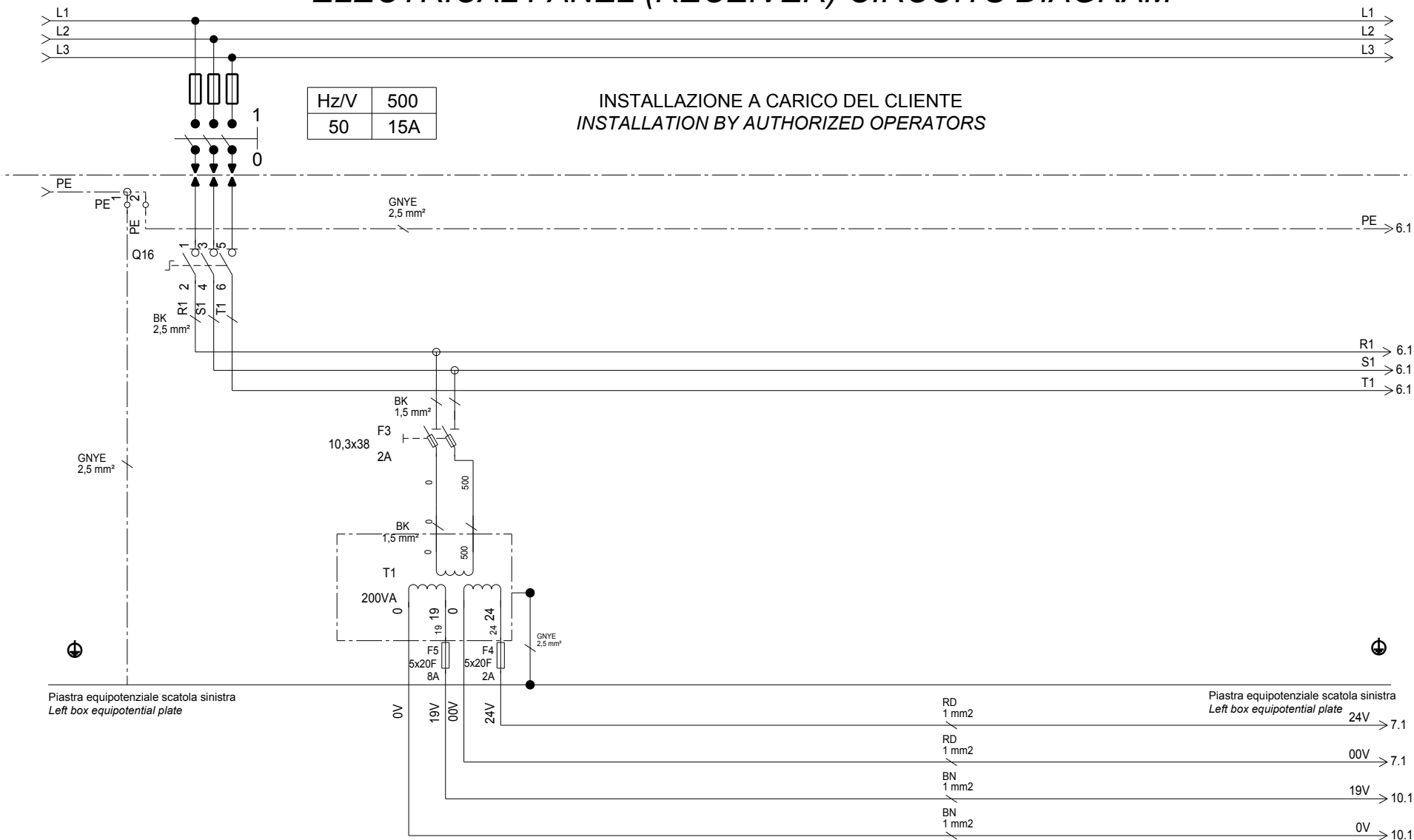

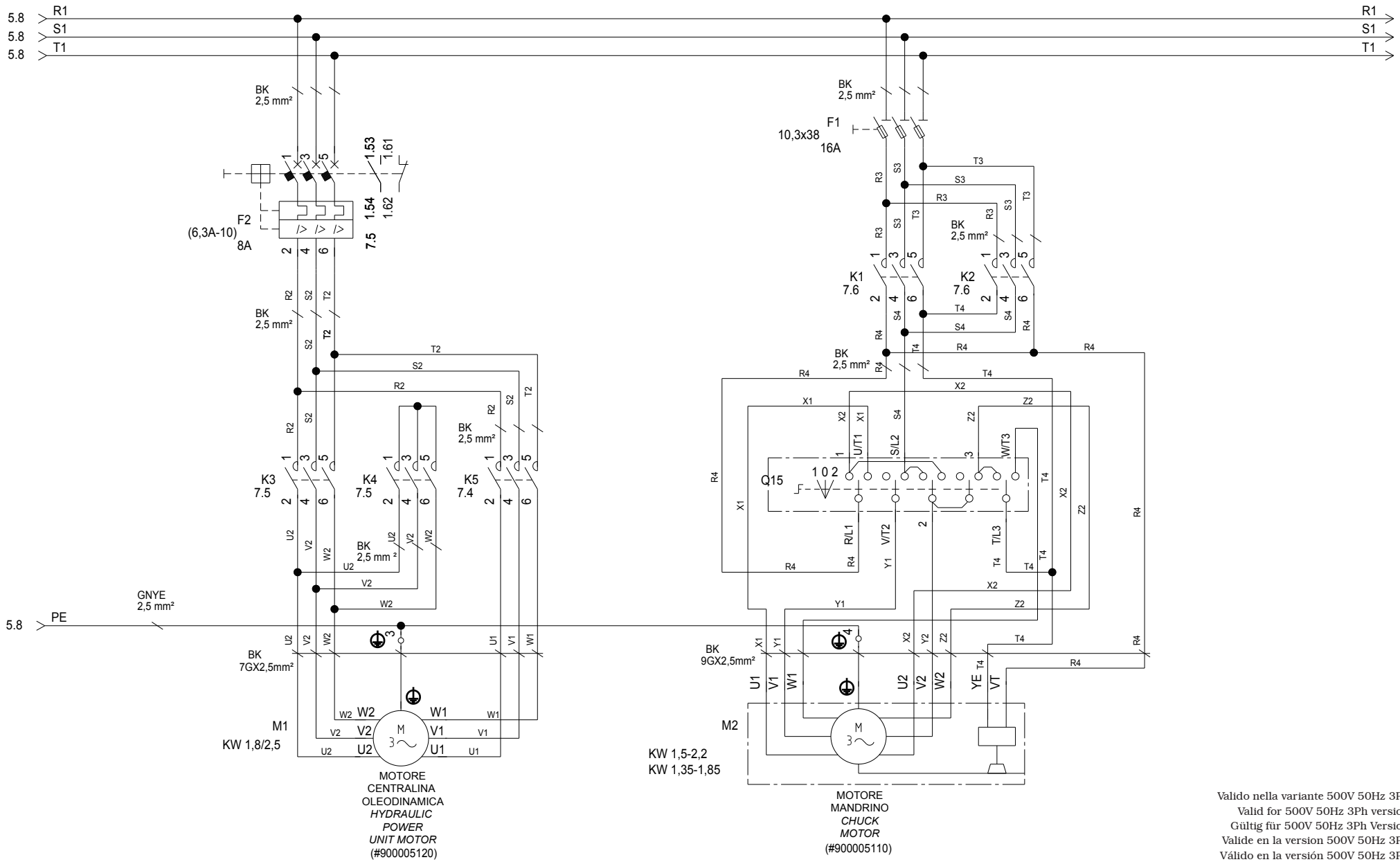

Valido nella variante 500V 50Hz 3Ph  
 Valid for 500V 50Hz 3Ph version  
 Gültig für 500V 50Hz 3Ph Version  
 Valide en la version 500V 50Hz 3Ph  
 Válido en la versión 500V 50Hz 3Ph



**LISTA DEI COMPONENTI - LIST OF COMPONENTS - TEILELISTE**  
**LISTE DES PIECES DETACHEES - LISTA DE PIEZAS**

**Tavola N°D - Rev. 0**

**790005590**

SCHEMA ELETTRICO 6/18  
 ELECTRICAL SCHEME 6/18  
 SCHALTPLAN 6/18  
 SCHEMA ELECTRIQUE 6/18  
 ESQUEMA ELECTRICO 6/18

**Pag. 74 di 88**  
**NAV43.15 - NAV63.15**

Valido nella variante 500V 50Hz 3Ph  
 Valid for 500V 50Hz 3Ph version  
 Gültig für 500V 50Hz 3Ph Version  
 Valide en la version 500V 50Hz 3Ph  
 Válido en la versión 500V 50Hz 3Ph

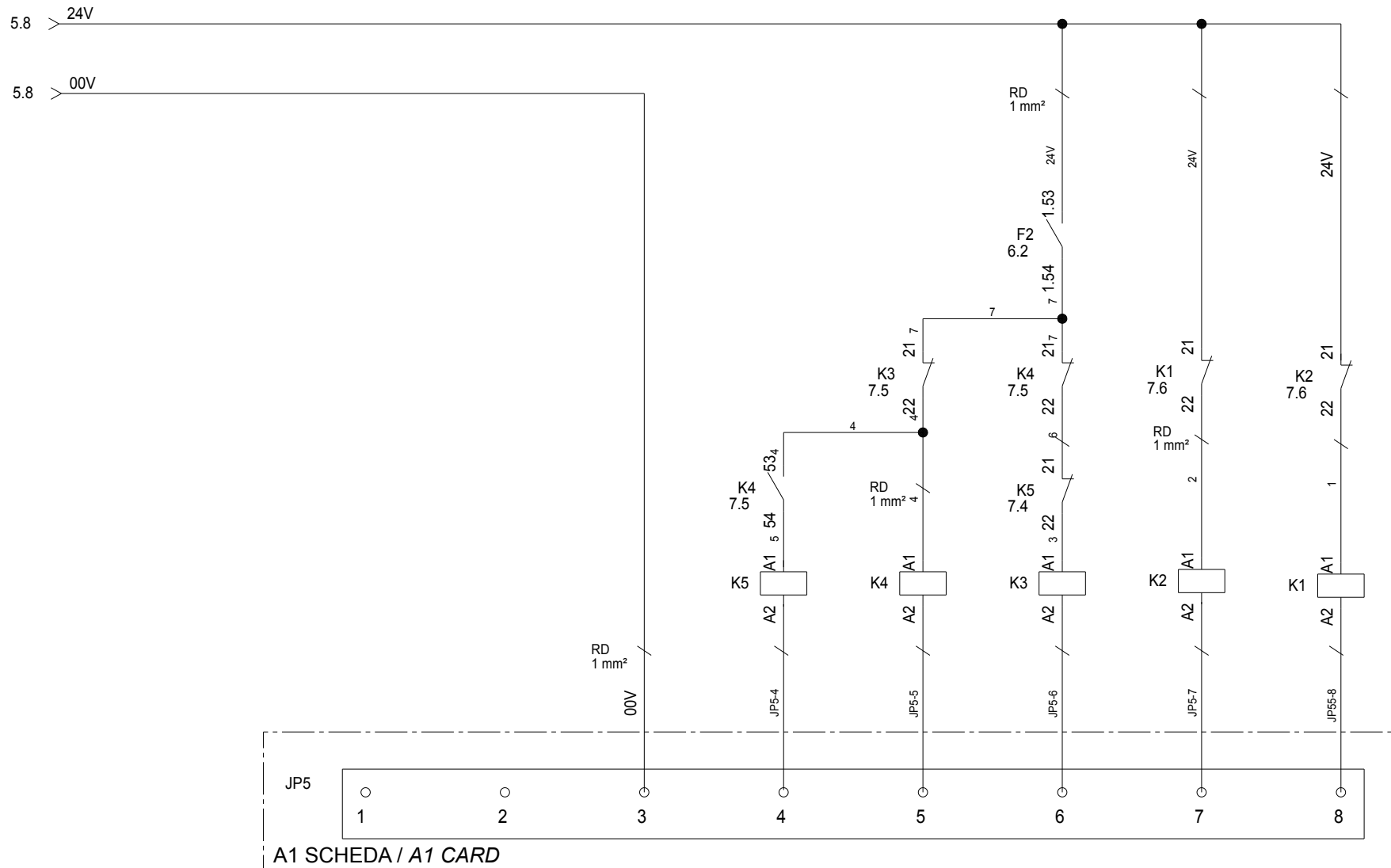

COMANDO ROTAZIONE 2V CENTRALINA OLEODINAMICA 2V HYDRAULIC POWER UNIT ROTATION CONTROL	COMANDO MOTORE CENTRALINA A STELLA 2V 2V STAR TYPE HYDRAULIC POWER UNIT MOTOR ROTATION CONTROL	COMANDO ROTAZIONE 1V CENTRALINA OLEODINAMICA 1V HYDRAULIC POWER UNIT ROTATION CONTROL	COMANDO ROTAZIONE ORARIA MANDRINO CHUCK CLOCKWISE ROTATION CONTROL	COMANDO ROTAZIONE ANTIORARIA MANDRINO CHUCK COUNTERCLOCKWISE ROTATION CONTROL
--	---	--	---	--



**LISTA DEI COMPONENTI - LIST OF COMPONENTS - TEILELISTE**  
**LISTE DES PIECES DETACHEES - LISTA DE PIEZAS**

**Tavola N°D - Rev. 0**

**790005590**

SCHEMA ELETTRICO 7/18  
 ELECTRICAL SCHEME 7/18  
 SCHALTPLAN 7/18  
 SCHEMA ELECTRIQUE 7/18  
 ESQUEMA ELECTRICO 7/18

**Pag. 75 di 88**  
**NAV43.15 - NAV63.15**



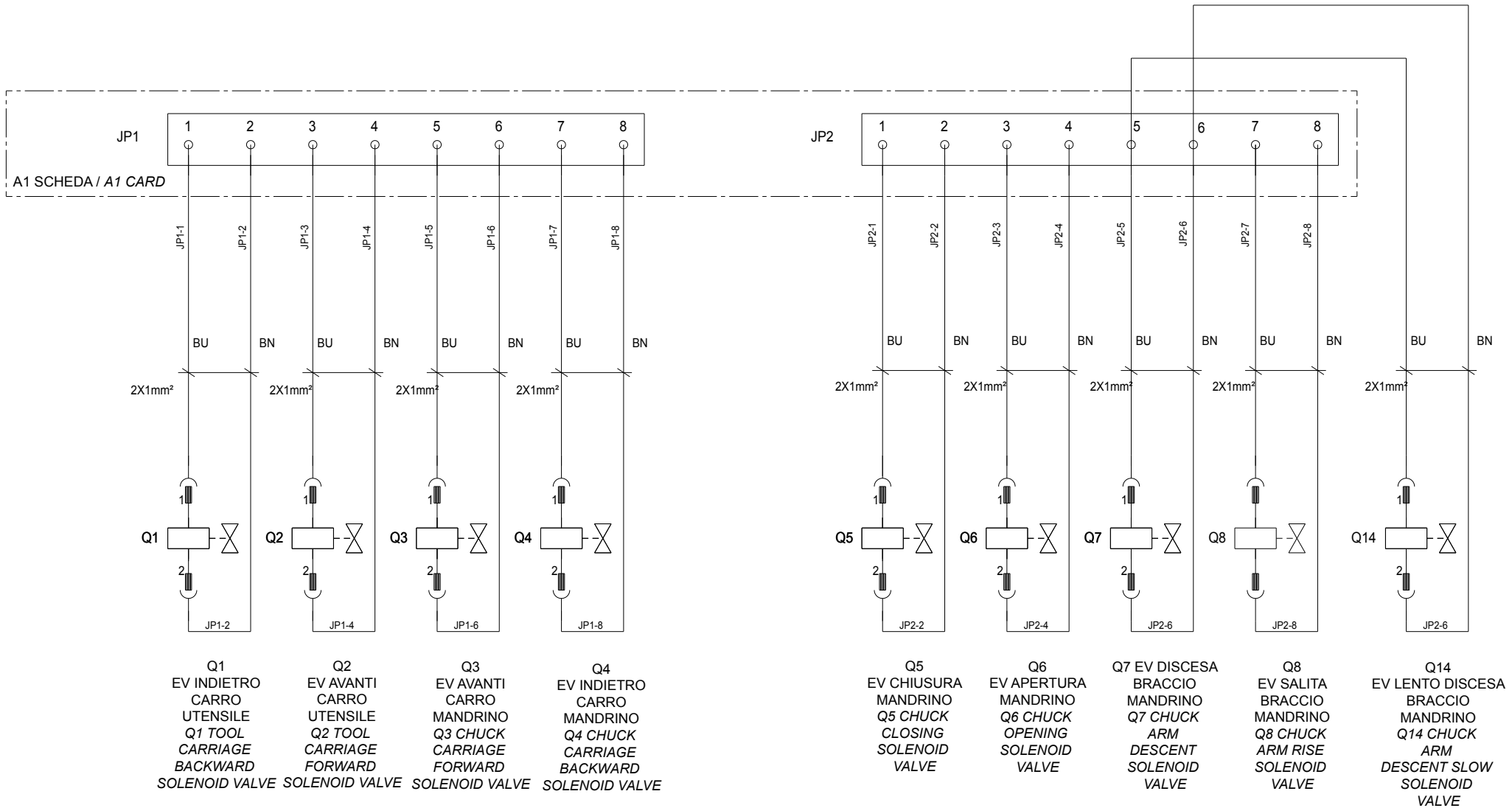

Valido nella variante 500V 50Hz 3Ph  
 Valid for 500V 50Hz 3Ph version  
 Gültig für 500V 50Hz 3Ph Version  
 Valide en la version 500V 50Hz 3Ph  
 Válido en la versión 500V 50Hz 3Ph

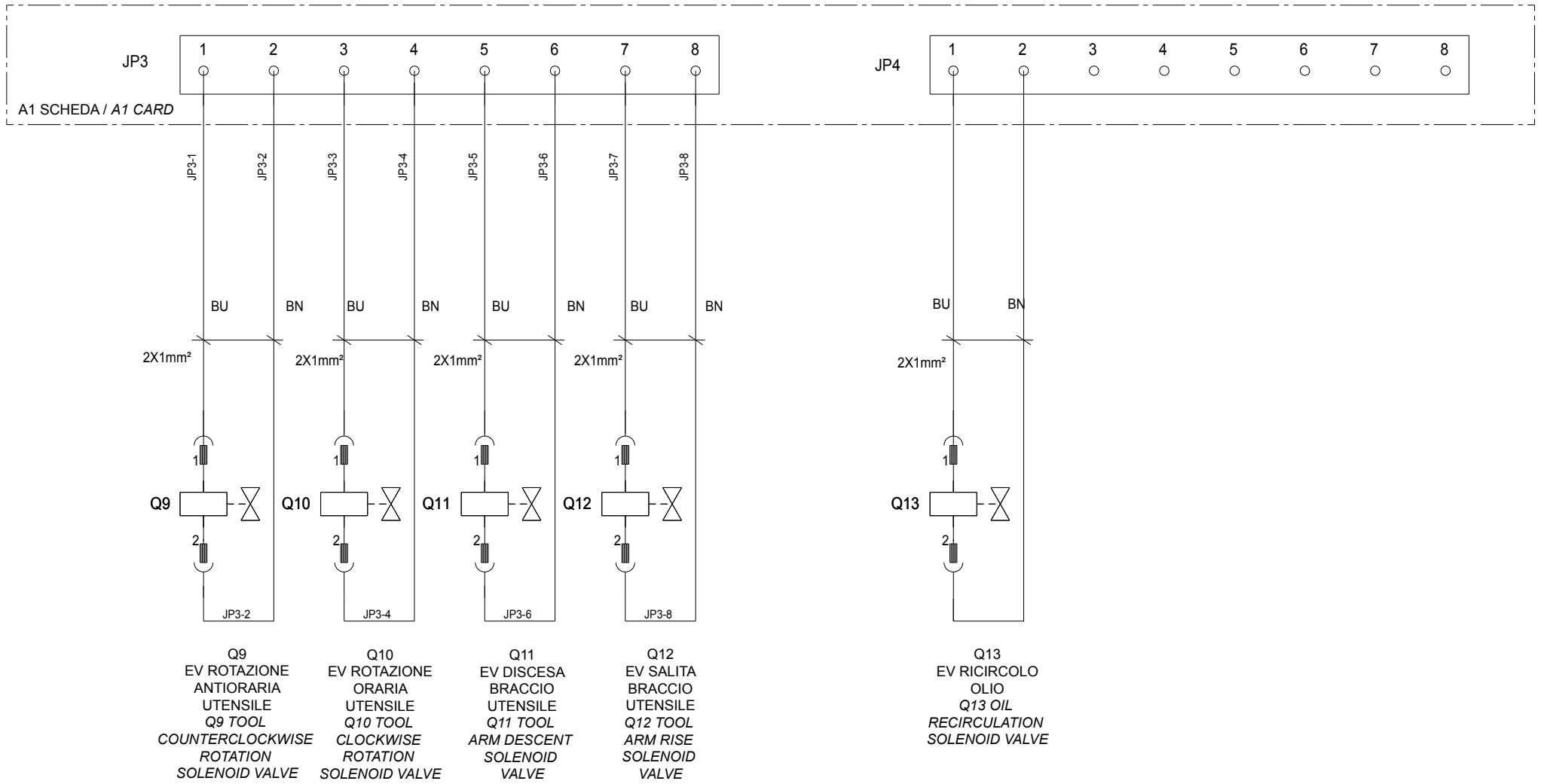

Valido nella variante 500V 50Hz 3Ph  
 Valid for 500V 50Hz 3Ph version  
 Gültig für 500V 50Hz 3Ph Version  
 Valide en la version 500V 50Hz 3Ph  
 Válido en la versión 500V 50Hz 3Ph



**LISTA DEI COMPONENTI - LIST OF COMPONENTS - TEILELISTE**  
**LISTE DES PIÈCES DÉTACHÉES - LISTA DE PIEZAS**

**Tavola N°D - Rev. 0**

**790005590**

SCHEMA ELETTRICO 9/18  
 ELECTRICAL SCHEME 9/18  
 SCHALTPLAN 9/18  
 SCHEMA ELECTRIQUE 9/18  
 ESQUEMA ELECTRICO 9/18

**Pag. 77 di 88**

**NAV43.15 - NAV63.15**

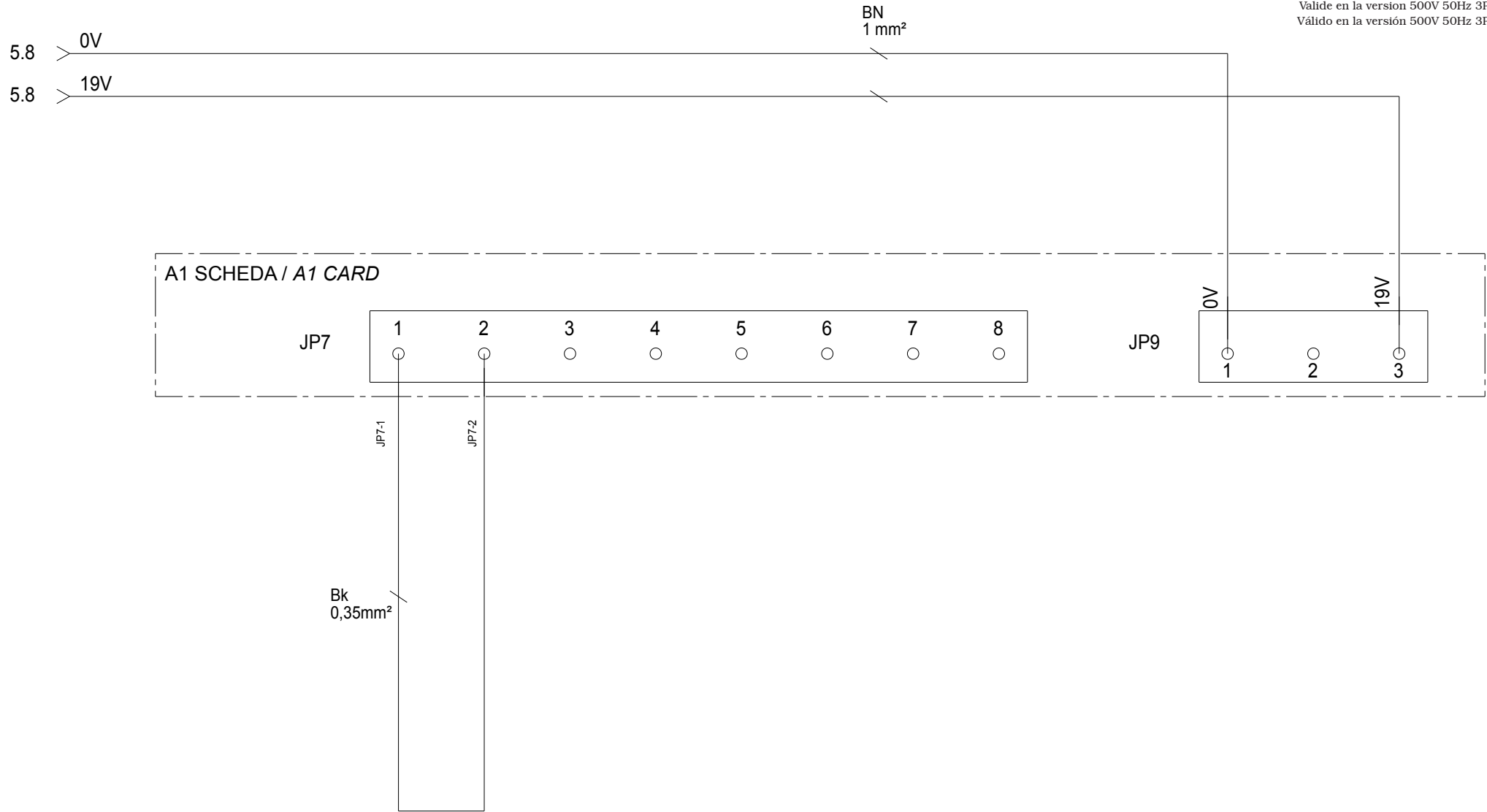

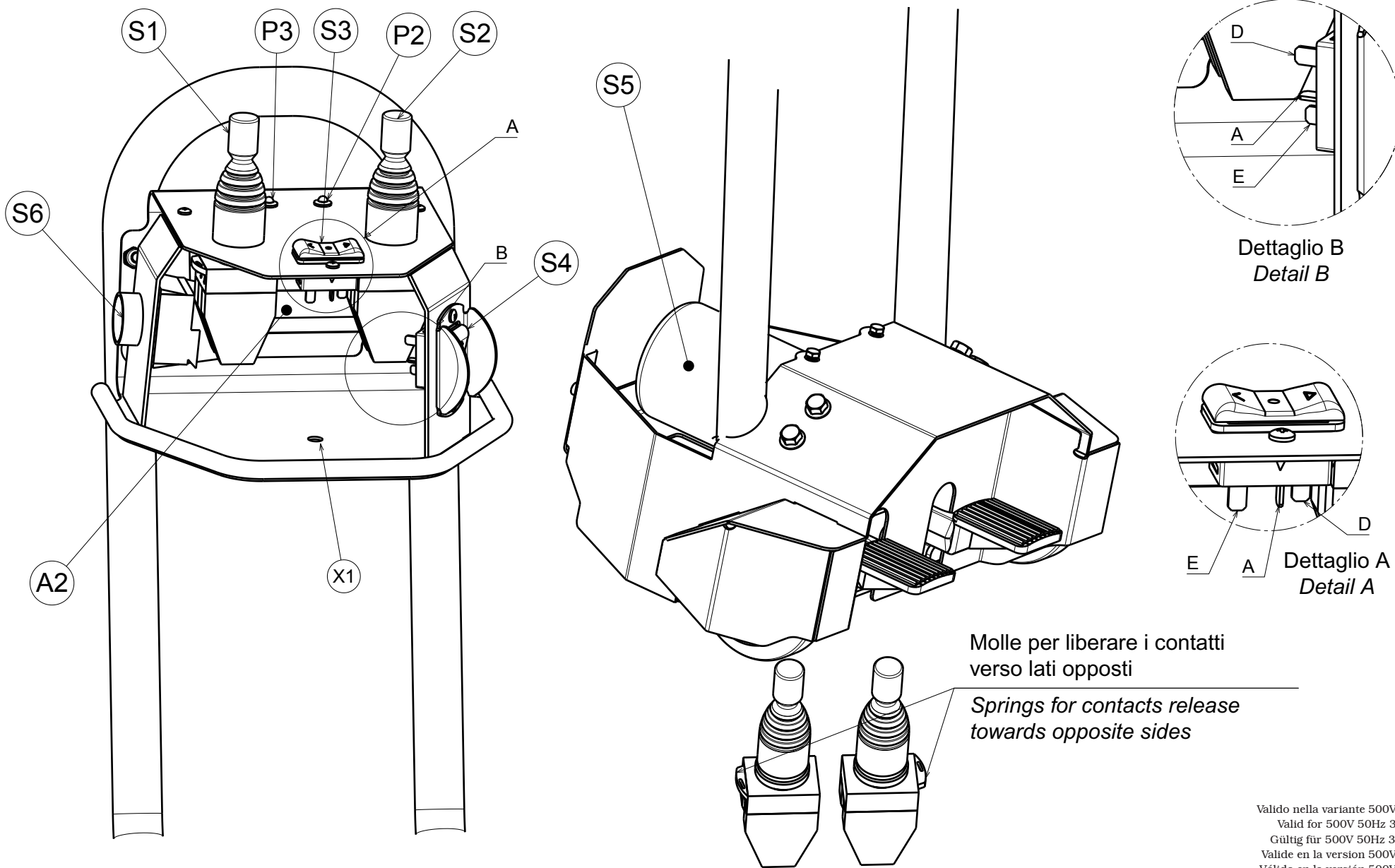

Valido nella variante 500V 50Hz 3Ph  
Valid for 500V 50Hz 3Ph version  
Gültig für 500V 50Hz 3Ph Version  
Válido en la versión 500V 50Hz 3Ph  
Válido en la versión 500V 50Hz 3Ph

 ENGINEERING and MARKETING S.P.A.	<b>LISTA DEI COMPONENTI - LIST OF COMPONENTS - TEILELISTE</b> <b>LISTE DES PIÈCES DÉTACHÉES - LISTA DE PIEZAS</b>		SCHEMA ELETTRICO 11/18 ELECTRICAL SCHEME 11/18 SCHALTPLAN 11/18 SCHEMA ELECTRIQUE 11/18 ESQUEMA ELECTRICO 11/18	<b>Pag. 79 di 88</b>
	<b>Tavola N°D - Rev. 0</b>	<b>790005590</b>		<b>NAV43.15 - NAV63.15</b>

# TOPOGRAFICO SCHEDA TRASMITTENTE 18961 TRANSMITTING CARD 18961 TOPOGRAPHIC VIEW

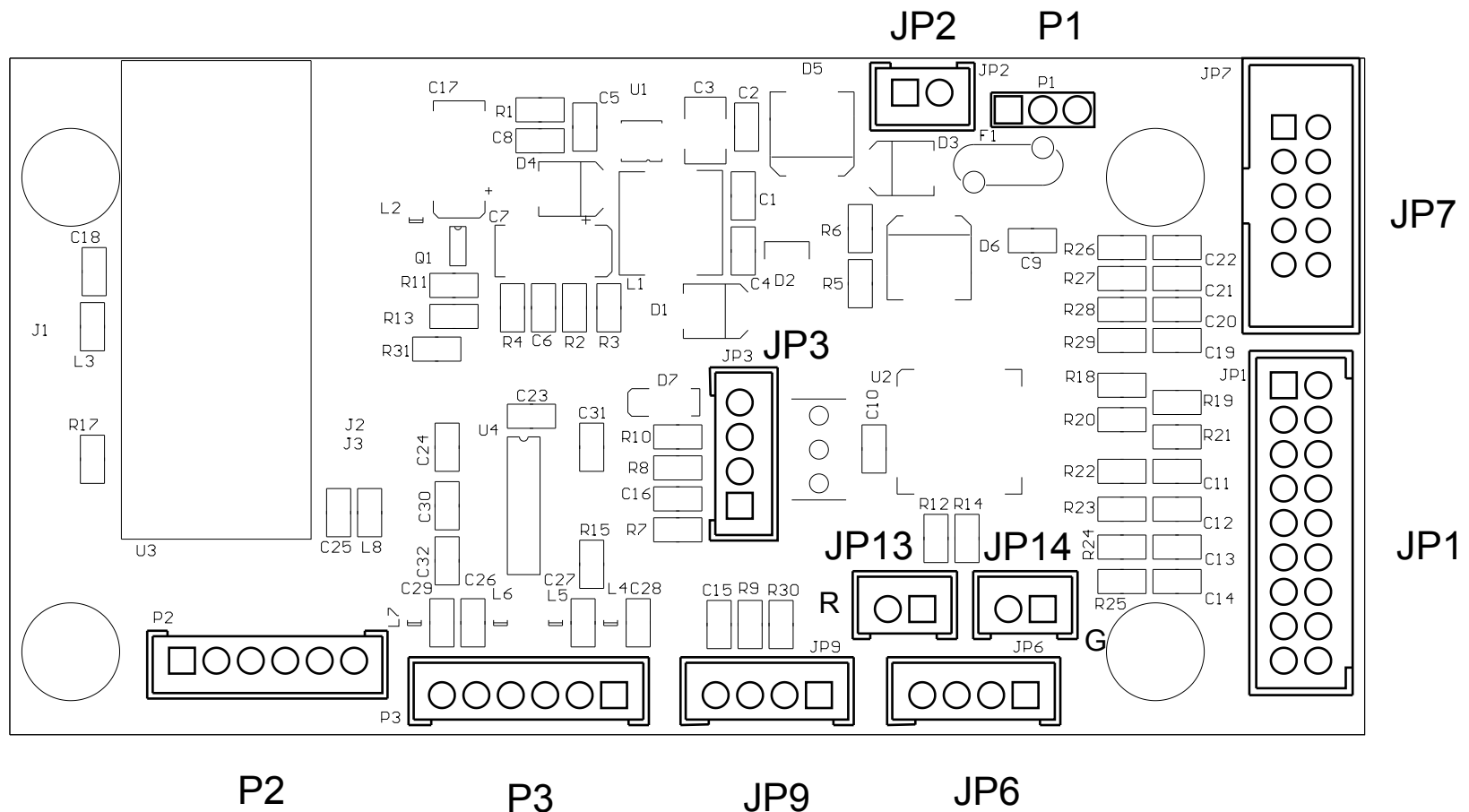

# IN/OUT SCHEDA TRASMITTENTE 18961

PIN JP1	NUMERO	FUNZIONE
1	JP1-1	S1 INDIETRO CARRO MANDRINO
2	JP1-2	S2 INDIETRO CARRO UTENSILE
3	JP1-3	S1 AVANTI CARRO MANDRINO
4	JP1-4	S2 AVANTI CARRO UTENSILE
5	JP1-5	S1 SALITA BRACCIO MANDRINO
6	JP1-6	S2 DISCESA BRACCIO UTENSILE
7	JP1-7	S1 DISCESA BRACCIO MANDRINO
8	JP1-8	S2 SALITA BRACCIO UTENSILE
9	JP1-9	S1 (COMUNE)
10	JP1-10	S2 (COMUNE)
11	JP1-11	S4 (COMUNE)
12	JP1-12	N.U.
13	JP1-13	S4 PULSANTE CHIUSURA MANDRINO
14	JP1-14	N.U.
15	JP1-15	S4 PULSANTE APERTURA MANDRINO
16	JP1-16	N.U.
17	JP1-17	S3 PULS.ROTAZ.ANTIOR. UTENS.
18	JP1-18	N.U.

PIN JP6	NUMERO	FUNZIONE
1	JP6-1	S5 SELETT.ROTAZ.ANTIOR. MANDRINO
2	JP6-2	S5 SELETT. ROTAZ.ORARIA MANDRINO
3	JP6-3	S3 PULS.ROTAZ.ORARIA UTENSILE
4	JP6-4	S5 COMUNE

PIN JP2	NUMERO	FUNZIONE
1	JP2-1	G2 BATTERIA -
2	JP2-2	G2 BATTERIA +

P1	NUMERO	FUNZIONE
X1		0-12Vdc

PIN JP9	NUMERO	FUNZIONE
1	JP9-1	S6 PULS. DOPPIA VELOC. CENTR.
2	JP9-2	N.U.
3	JP9-3	S3 (COMUNE)
4	JP9-4	S6 PULS. DOPPIA VELOC. CENTR.

PIN JP13	NUMERO	FUNZIONE
1	JP13-1	P2 LED ROSSO +
2	JP13-2	P2 LED ROSSO -

PIN JP14	NUMERO	FUNZIONE
1	JP14-1	P3 LED VERDE +
2	JP14-2	P3 LED VERDE -

Valido nella variante 500V 50Hz 3Ph  
Valid for 500V 50Hz 3Ph version  
Gültig für 500V 50Hz 3Ph Version  
Valide en la version 500V 50Hz 3Ph  
Válido en la versión 500V 50Hz 3Ph

# TRANSMITTING CARD 18961 IN/OUT

PIN JP1	NUMBER	FUNCTION
1	JP1-1	S1 CHUCK CARRIAGE BACKWARD
2	JP1-2	S2 TOOL CARRIAGE BACKWARD
3	JP1-3	S1 CHUCK CARRIAGE FORWARD
4	JP1-4	S2 TOOL CARRIAGE FORWARD
5	JP1-5	S1 CHUCK ARM RISE
6	JP1-6	S2 TOOL ARM DESCENT
7	JP1-7	S1 CHUCK ARM DESCENT
8	JP1-8	S2 TOOL ARM RISE
9	JP1-9	S1 (COMMON)
10	JP1-10	S2 (COMMON)
11	JP1-11	S4 (COMMON)
12	JP1-12	N.U.
13	JP1-13	S4 CHUCK CLOSING PUSHBUTTON
14	JP1-14	N.U.
15	JP1-15	S4 CHUCK OPENING PUSHBUTTON
16	JP1-16	N.U.
17	JP1-17	S3 TOOL COUNTERCLOCKWISE ROT. PUSHBUTTON
18	JP1-18	N.U.

PIN JP6	NUMBER	FUNCTION
1	JP6-1	S5 CHUCK COUNTERCLOCKWISE ROT. SELECTOR
2	JP6-2	S5 CHUCK CLOCKWISE ROT. SELECTOR
3	JP6-3	S3 TOOL CLOCKWISE ROT. PUSHBUTTON
4	JP6-4	S5 COMMON

PIN JP2	NUMBER	FUNCTION
1	JP2-1	G2 BATTERY -
2	JP2-2	G2 BATTERY +

P1	NUMBER	FUNCTION
X1		0-12Vdc

PIN JP9	NUMBER	FUNCTION
1	JP9-1	S6 HYDR. POWER UNIT DOUBLE SPEED PUSHBUTTON
2	JP9-2	N.U.
3	JP9-3	S3 (COMMON)
4	JP9-4	S6 HYDR. POWER UNIT DOUBLE SPEED PUSHBUTTON

PIN JP13	NUMBER	FUNCTION
1	JP13-1	P2 RED LED +
2	JP13-2	P2 RED LED -

PIN JP14	NUMBER	FUNCTION
1	JP14-1	P3 GREEN LED +
2	JP14-2	P3 GREEN LED -

Valido nella variante 500V 50Hz 3Ph  
 Valid for 500V 50Hz 3Ph version  
 Gültig für 500V 50Hz 3Ph Version  
 Valide en la version 500V 50Hz 3Ph  
 Válido en la versión 500V 50Hz 3Ph

# SCHEMA CIRCUITI MANIPOLATORE A TERRA (TRASMETTITORE) GROUND HANDLE CONTROL (TRANSMITTER) CIRCUITS DIAGRAM

Valido nella variante 500V 50Hz 3Ph  
Valid for 500V 50Hz 3Ph version  
Gültig für 500V 50Hz 3Ph Version  
Valide en la version 500V 50Hz 3Ph  
Válido en la versión 500V 50Hz 3Ph

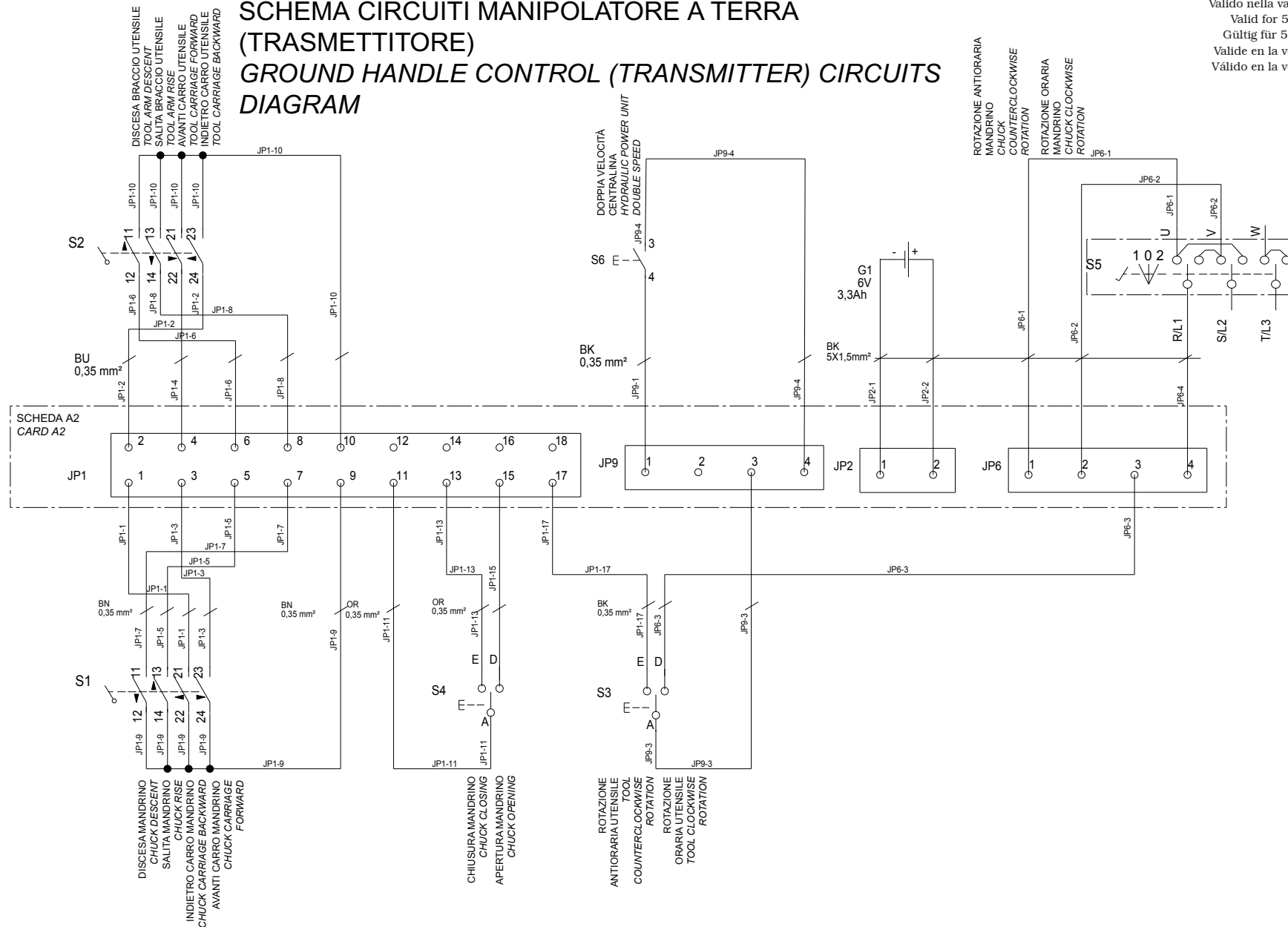



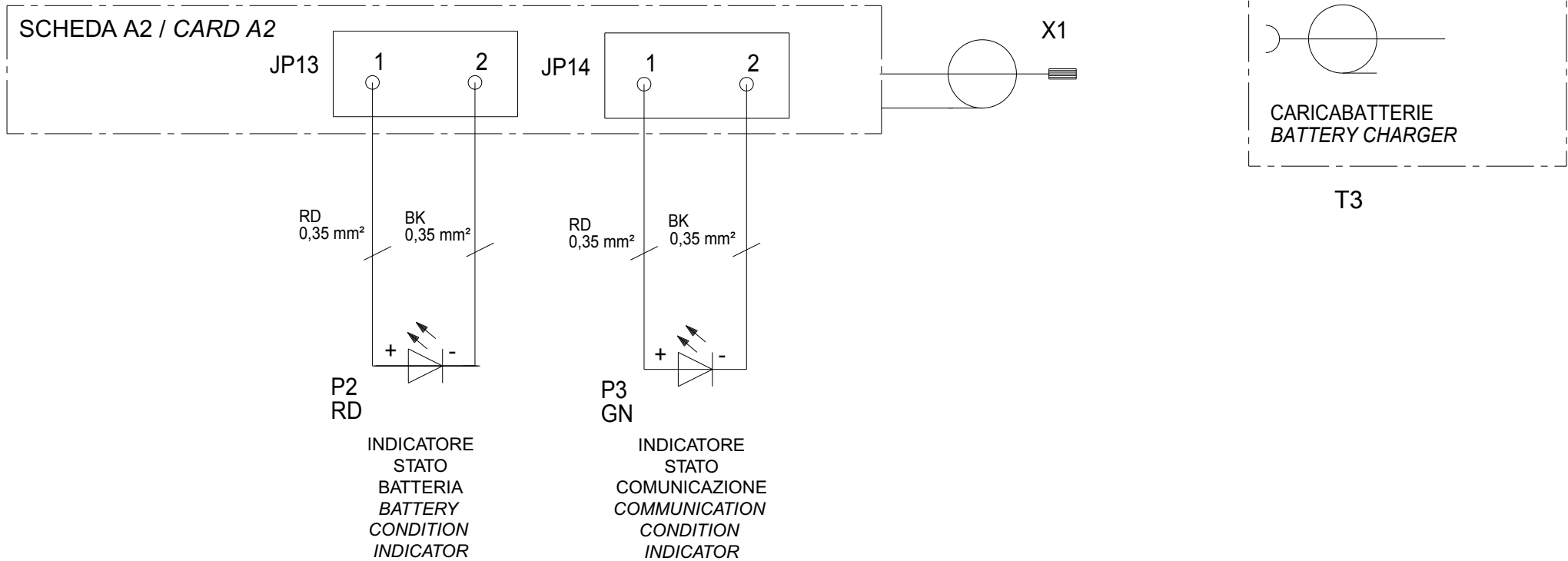

 ENGINEERING and MARKETING S.P.A.	LISTA DEI COMPONENTI - LIST OF COMPONENTS - TEILELISTE LISTE DES PIECES DETACHEES - LISTA DE PIEZAS		SCHEMA ELETTRICO 16/18 ELECTRICAL SCHEME 16/18 SCHALTPLAN 16/18 SCHEMA ELECTRIQUE 16/18 ESQUEMA ELECTRICO 16/18	Pag. 84 di 88
	Tavola N°D - Rev. 0	790005590		NAV43.15 - NAV63.15

# LISTA COMPONENTI

Valido nella variante 500V 50Hz 3Ph  
Valid for 500V 50Hz 3Ph version  
Gültig für 500V 50Hz 3Ph Version  
Valide en la version 500V 50Hz 3Ph  
Válido en la versión 500V 50Hz 3Ph

RIFERIMENTO	DESCRIZIONE	DATI TECNICI	SIGLA CATALOGO	QUANTITA	RIFERIMENTO DOCUMENTO
A1	SCHEDA ELETT. RICEVENTE	-	18962	1	2.5
A2	SCHEDA ELETT. TRASMITTENTE	-	18961	1	11.2
F1	PORTAFUSIBILE	3 POLI SEZIONABILE 10,3x38 32A 690V	515025	1	6.6
	FUSIBILE	10,3x38 16A 500V aM RITARDATO	507045	3	
F2	INTERRUTTORE AUTOM. TRIPOLARE	6,3-10A AC3 400V 2,2KW	518277	1	6.2
	CONTATTI AUSILIARI	1NO+1NC ATTACCO FRONTALE	518279	1	
F3	PORTAFUSIBILE	2 POLI SEZIONABILE 10,3x38 32A 690V	515027	1	5.3
	FUSIBILE	10,3X38 2A 500V RAPIDO	507019	2	
F4	FUSIBILE	5x20F 250V 2A RAPIDO	507043	1	5.3
F5	FUSIBILE	5x20F 250V 8A RAPIDO	507090	1	5.3
F6	FUSIBILE	5X20 T 8A 250V	507118	1	5.7
G1	BATTERIA	6V 3,3AH/20HR Lead	10066	1	14.6
K1	CONTATTORE TRIPOLARE	9A AC3 400V 4,2KW 1NC 24Vac 50/60Hz	522137	1	7.6
K2	CONTATTORE TRIPOLARE	9A AC3 400V 4,2KW 1NC 24Vac 50/60Hz	522137	1	7.6
K3	CONTATTORE TRIPOLARE	9A AC3 400V 4,2KW 1NC 24Vac 50/60Hz	522137	1	7.5
K4	CONTATTORE TRIPOLARE	9A AC3 400V 4,2KW 1NC 24Vac 50/60Hz	522137	1	7.5
	CONTATTI AUSILIARI	1NO+1NC ATTACCO FRONTALE	522147	1	
K5	CONTATTORE	9A AC3 400V 4,2KW 1NC 24Vac 50/60Hz	522137	1	7.4
P2	INDICATORE LUMINOSO (LED)	ROSSO	18065	1	15.4
P3	INDICATORE LUMINOSO (LED)	VERDE	18066	1	15.5
Q1...Q14	ELETTROVALVOLE	-	-	14	8-9
Q16	SEZIONATORE TRIPOLARE	1th 32A Ui 690V-50Hz Uimp 4KW	518223+518226	1	5.2
Q15	COMMUTATORE DI POLI DAHLANDER	25A 500V	518189	1	6.5-6.6
S1	MANIPOLATORE	4 POS.+CENTR.TEMPORANEE Ø22	517157AS	1	14.2
S2	MANIPOLATORE	4 POS.+CENTR.TEMPORANEE Ø22	517157AS	1	14.2
S3	PULSANTE BASCULANTE	-	517283	1	14.5
S4	PULSANTE BASCULANTE	-	517283	1	14.4
S5	COMMUTATORE	1th 25A Ui 690V-50Hz Uimp 4KW	518058	1	14.7-14.8
S6	PULSANTE	-	517105AS	1	14.5
T1	TRASFORMATORE	200 VA 50/60 Hz PRI: 0/500V SEC: 0/19V 8,95A 0/24V 1,25A	528095	1	5.3
-	-	-	-	-	-
T3	CARICABATTERIA	21.6W 7.2V 3A Lithium ion	18064	1	15.6
M1	MOTORE CENTRALINA NAV63.15 NAV43.15	M.E.1.8-2.5 500V 3Ph SX B3-B14 50Hz	900005120	1	6.3
M2	MOTORE MANDRINO NAV63.15	M.E.KW1.5/2.2 500V 3Ph 50Hz B3G90L	900005110	1	6.5

# COMPONENTS LIST

Valido nella variante 500V 50Hz 3Ph  
Valid for 500V 50Hz 3Ph version  
Gültig für 500V 50Hz 3Ph Version  
Valide en la version 500V 50Hz 3Ph  
Válido en la versión 500V 50Hz 3Ph

REFERENCE	DESCRIPTION	TECHNICAL SPECIFICATIONS	ABBREVIATION ON CATALOGUE	QUANTITY	DOCUMENT REFERENCE
A1	RECEIVING ELECTRICAL CARD	-	18962	1	2.5
A2	TRANSMITTING ELECTRICAL CARD	-	18961	1	11.2
F1	FUSE HOLDER	10,3x38 32A 690V SECTIONABLE 3 POLES	515025	1	6.6
	FUSE	10,3x38 16A 500V aM DELAYED-ACTION	507045	3	
F2	TRIPOLAR AUTOMATIC SWITCH	6,3-10A AC3 400V 2,2KW	518277	1	6.2
	AUXILIARY CONTACTS	1NO+1NC FRONT COUPLING	518279	1	6.2
F3	FUSE HOLDER	10,3x38 32A 690V SECTIONABLE 2 POLES	515027	1	5.3
	FUSE	10,3X38 2A 500V RAPID	507019	2	
F4	FUSE	5x20F 250V 2A RAPID	507043	1	5.3
F5	FUSE	5x20F 250V 8A RAPID	507090	1	5.3
F6	FUSE	5X20 T 8A 250V	507118	1	5.7
G1	BATTERY	6V 3,3AH/20HR Lead	10066	1	14.6
K1	TRIPOLAR CONTACTOR	9A AC3 400V 4,2KW 1NC 24Vac 50/60Hz	522137	1	7.6
K2	TRIPOLAR CONTACTOR	9A AC3 400V 4,2KW 1NC 24Vac 50/60Hz	522137	1	7.6
K3	TRIPOLAR CONTACTOR	9A AC3 400V 4,2KW 1NC 24Vac 50/60Hz	522137	1	7.5
K4	TRIPOLAR CONTACTOR	9A AC3 400V 4,2KW 1NC 24Vac 50/60Hz	522137	1	7.5
	AUXILIARY CONTACTS	1NO+1NC FRONT COUPLING	522147	1	7.4
K5	CONTACTOR	9A AC3 400V 4,2KW 1NC 24Vac 50/60Hz	522137	1	7.4
P2	BACKLIGHTED INDICATOR (LED)	RED	18065	1	15.4
P3	BACKLIGHTED INDICATOR (LED)	GREEN	18066	1	15.5
Q1...Q14	SOLENOID VALVES	-	-	14	8-9
Q16	TRIPOLAR KNIFE SWITCH	1th 32A Ui 690V-50Hz Uimp 4KW	518223 + 518226	1	5.2
Q15	DAHLANDER POLES COMMUTATOR	25A 500V	518189	1	6.5-6.6
S1	HANDLE CONTROL	4 POS.+ CENTRAL POS. TEMPORARY Ø22	517157AS	1	14.2
S2	HANDLE CONTROL	4 POS.+ CENTRAL POS. TEMPORARY Ø22	517157AS	1	14.2
S3	BALANCING PUSHBUTTON	-	517283	1	14.5
S4	BALANCING PUSHBUTTON	-	517283	1	14.4
S5	COMMUTATOR	1th 25A Ui 690V-50Hz Uimp 4KW	518058	1	14.7-14.8
S6	PUSHBUTTON	-	517105AS	1	14.5
T1	TRANSFORMER	200 VA 50/60 Hz PRI: 0/500V SEC: 0/19V 8,95A 0/24V 1,25A	528056	1	5.3
-	-	-	-	-	-
T3	BATTERY CHARGER	21.6W 7.2V 3A Lithium ion	18064	1	15.6
M1	HYDRAULIC POWER UNIT MOTOR NAV63.15 NAV43.15	M.E.1.8-2.5 500V 3Ph SX B3-B14 50Hz	900005120	1	6.3
M2	CHUCK MOTOR NAV63.15	M.E.KW1.5/2.2 500V 3Ph 50Hz B3G90L	900005110	1	6.5

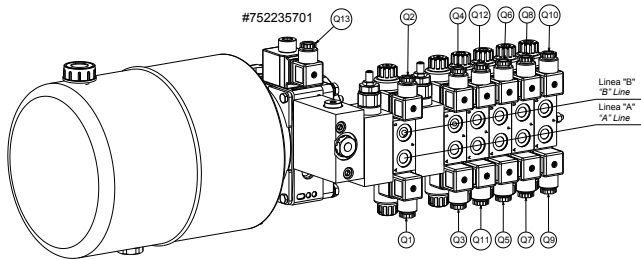
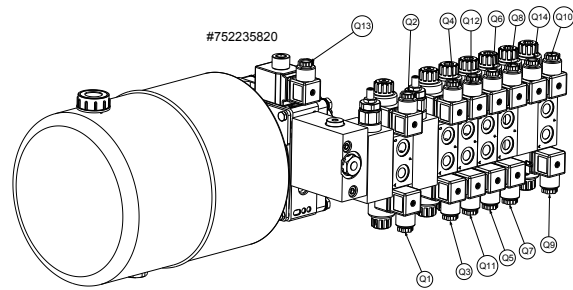

CENTRALINA #752235820 COMANDO BLUETOOTH  
BLUETOOTH CONTROL #752235820 HYDRAULIC POWER UNIT

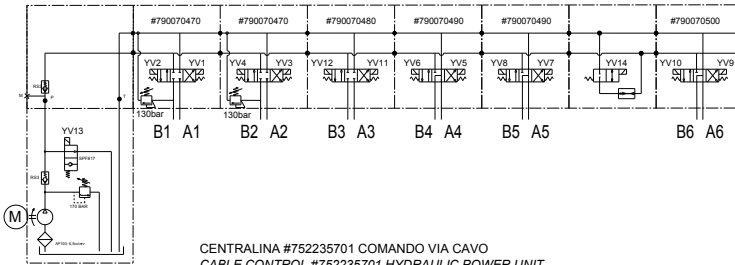

CENTRALINA #752235701 COMANDO VIA CAVO  
CABLE CONTROL #752235701 HYDRAULIC POWER UNIT

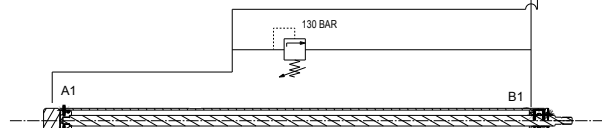
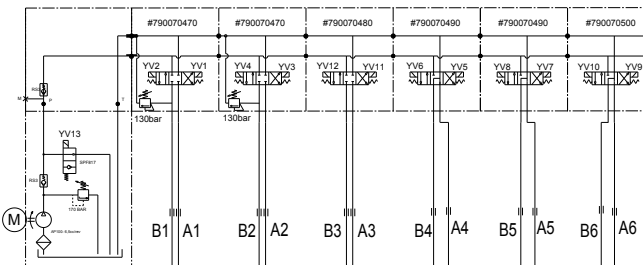

752290530 - CILINDRO TRASLAZIONE CARRO UTENSILE  
752290530 - TOOL CARRIAGE TRANSLATION CYLINDER

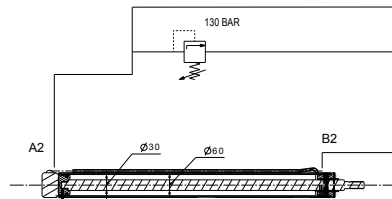

752290410 - CILINDRO TRASLAZIONE CARRO MANDRINO  
752290410 - CHUCK CARRIAGE TRANSLATION CYLINDER

752290130 - CILINDRO APERTURA MANDRINO  
752290130 - CHUCK OPENING CYLINDER

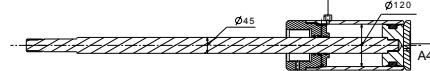

752216020 - BLOCCO MANDRINO SE  
752216020 - SE CHUCK BLOCK



752290260 - CILINDRO SALITA/DISCESA BRACCIO MANDRINO  
752290260 - CHUCK ARM UP/DOWN CYLINDER

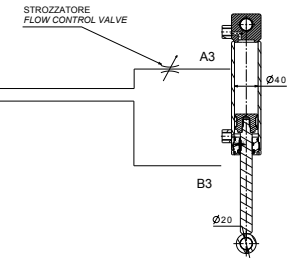

752290240 - CILINDRO ALZATA/BLOCCAGGIO UTENSILE  
752290240 - RAISING CYLINDER/TOOL LOCKING

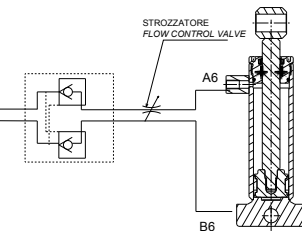

146501050 - ROTAZIONE UTENSILE  
146501050 - TOOL ROTATION

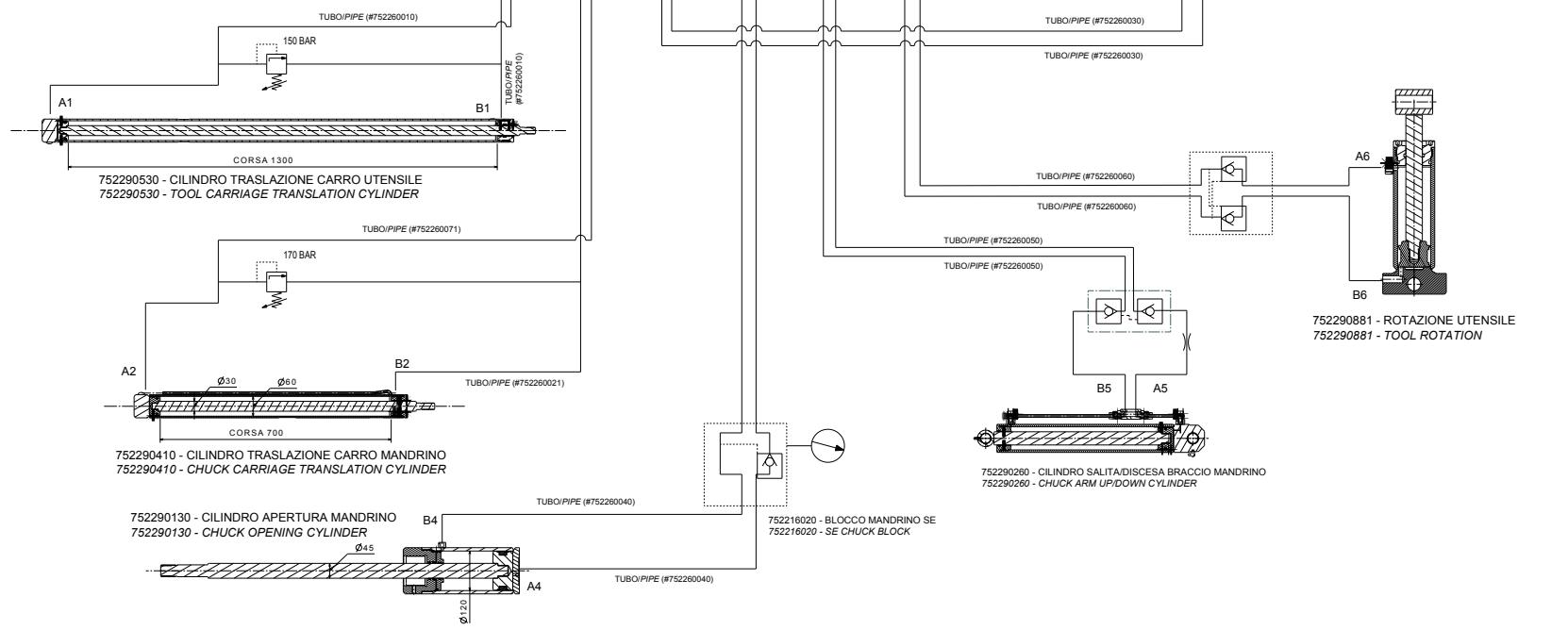
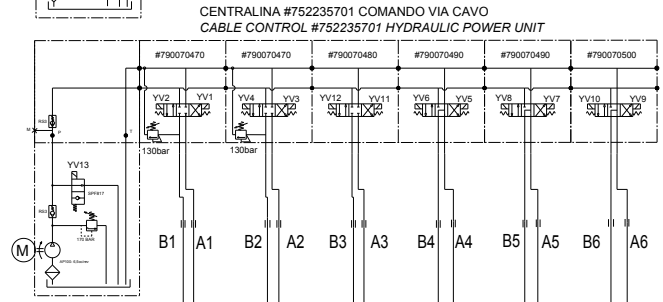
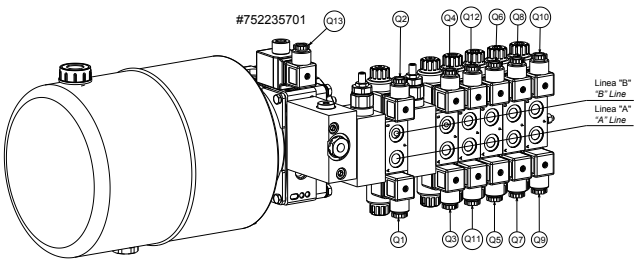
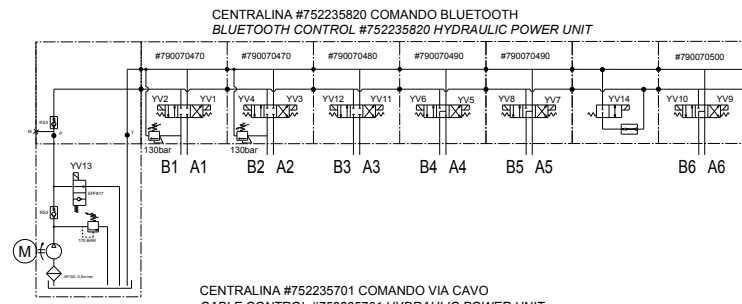
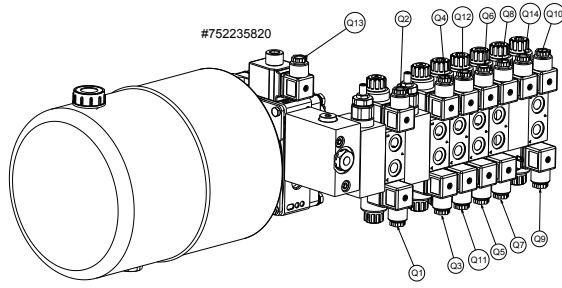



Noi  
We / Wir / Nous / Nosotros

**BUTLER ENGINEERING AND MARKETING S.p.A.s.u.**  
**Via dell'Ecologia, 6**  
**42047 Rolo RE ITALIA**

**dichiariamo sotto la nostra esclusiva responsabilità che il prodotto**

*declare, undertaking sole responsibility, that the product*  
*erklären unter unserer alleinigen Verantwortung, dass das Produkt*  
*déclarons, sous notre entière responsabilité, que le produit*  
*declaramos bajo nuestra exclusiva responsabilidad, que el producto*

<b>Smontagomme</b> Tyre changer Reifenmontiermaschine Démonte-Pneus Desmontadora	
--	--

**al quale questa dichiarazione si riferisce, risponde alle seguenti Direttive applicabili:**

*to which this declaration applies is in compliance with the following applicable Directives:*  
*auf das sich diese Erklärung bezieht, den nachstehenden anwendbaren Normen entspricht:*  
*objet de cette déclaration est conforme aux Directives applicables suivantes:*  
*al que se refiere esta declaración cumple con las siguientes Normas aplicables:*

**2006/42/CE**                      Direttiva Macchine  
**2014/30/UE**                      Direttiva Compatibilità Elettromagnetica

**Per la conformità alle suddette direttive sono state seguite le seguenti Norme Armonizzate:**

*To comply with the above mentioned Directives, we have followed the following harmonized directives:*  
*In Übereinstimmung mit o.g. Richtlinien wurden folgende harmonisierte Normen befolgt:*  
*Pour la conformité aux normes ci-dessus, nous avons suivi les normes harmonisées suivantes:*  
*Para la conformidad a las Normas arriba mencionadas, hemos seguido las siguientes Normas armonizadas:*

**UNI EN ISO 12100:2010**                      Sicurezza del macchinario – Principi generali di progettazione – Valutazione del rischio e riduzione del rischio  
**CEI EN 60204-1:2018**                      Sicurezza del macchinario – Equipaggiamento elettrico delle macchine – Parte 1 – Regole generali

**La persona preposta a costituire il fascicolo tecnico è Butler S.p.A. s.u.**

*The technical documentation file is constituted by Butler S.p.A.s.u.*  
*Vorgesetzte Rechtsperson für die Erstellung des technischen Maschinenheftes ist Butler S.p.A.s.u.*  
*La société Butler S.p.A.s.u. est l'organisme délégué à la présentation de la documentation technique.*  
*Butler S.p.A.s.u. es encargata a la constitución del archivo técnico.*

Rolo,



## Dichiarazione di Conformità

Declaration of Conformity  
Konformitätserklärung  
Déclaration de Conformité  
Declaración de Conformidad



Vehicle Service Group Italy S.r.l.

via Brunelleschi, 9

44020 San Giovanni di Ostellato (Ferrara) – ITALIA

Noi

Wir / Wir / Nous / Nosotros

dichiariamo sotto la nostra esclusiva responsabilità che il prodotto

declare, undertaking sole responsibility, that the product  
erklären unter unserer alleinigen Verantwortung, dass das Produkt  
déclarons, sous notre entière responsabilité, que le produit,  
declaramos bajo nuestra exclusiva responsabilidad, que el producto

Smontagomme / Tyre Changer Reifenmontiermaschinen / Démonte Pneus Desmonta Neumáticos	
---	--

al quale questa dichiarazione si riferisce, risponde alle seguenti Direttive applicabili:

to which this declaration applies is in compliance with the following applicable Directives:  
auf das sich diese Erklärung bezieht, den nachstehenden anwendbaren Normen entspricht:  
objet de cette déclaration est conforme aux Directives applicables suivantes:  
al que se refiere esta declaración cumple con las siguientes Normas aplicables:

2006/42/CE  
2014/30/UE

Direttiva Macchine  
Direttiva Compatibilità Elettromagnetica

Per la conformità alle suddette direttive sono state seguite le seguenti Norme Armonizzate:

To comply with the above mentioned Directives, we have followed the following harmonized directives:  
In Übereinstimmung mit o.g. Richtlinien wurden folgende harmonisierte Normen befolgt:  
Pour la conformité aux normes ci-dessus, nous avons suivi les normes harmonisées suivantes:  
Para la conformidad a las Normas arriba mencionadas, hemos seguido las siguientes normas armonizadas:

UNI EN ISO 12100:2010

Sicurezza del macchinario – Principi generali di progettazione - Valutazione del rischio e riduzione del rischio

CEI EN 60204-1:2018

Sicurezza del macchinario – Equipaggiamento elettrico delle macchine - Parte 1: Regole generali

La persona preposta a costruire il fascicolo tecnico è Vehicle Service Group Italy S.r.l.

The technical documentation file is constituted by Vehicle Service Group Italy S.r.l.

Vorgesetzte Rechtsperson für die Erstellung des technischen Lastenheftes ist Vehicle Service Group Italy S.r.l.

La société Vehicle Service Group Italy S.r.l. est l'organisme délégué à la présentation de la documentation technique.

Vehicle Service Group Italy S.r.l. es encargata a la constitución del archivo técnico.

SIMONE FERRARI  
VP VSG Europe Managing Director

S.G. di Ostellato, / /

7506-DC002R 01/07/2023

Il modello della presente dichiarazione è conforme alla norma

The version of this declaration conforms to the regulation  
Das Modell der vorliegenden Erklärung entspricht der Norm  
Le modèle de la présente déclaration est conforme à la norme  
El modelo de la presente declaración cumple la norma

UNI CEI EN ISO/IEC 17050-1



UK Declaration of Conformity



We

Vehicle Service Group Italy S.r.l.  
via Brunelleschi, 9  
44020 San Giovanni di Ostellato (Ferrara) – ITALIA

declare, undertaking sole responsibility, that the product

Tyre Changer	
--------------	--

to which this declaration applies is in compliance with the following applicable Regulations:

**The Supply of Machinery (Safety) Regulations 2008**

**The Electrical Equipment (Safety) Regulations 2016**

**Electromagnetic Compatibility Regulations 2016**

To comply with the above mentioned Regulations, we have followed, totally, the following designated standards

- BS EN ISO 12100:2010** Safety of machinery. General principles for design. Risk assessment and risk reduction.
- BS EN 60204-1:2018** Safety of machinery. Electrical equipment of machines. General requirements.
- BS EN 61000-6-3:2007 +A1:2011 +AC:2012** Electromagnetic compatibility (EMC) - Part 6-3. Generic Standards - Emission standard for residential, commercial and light-industrial environments.
- BS EN 61000-6-2:2005 +AC:2005** Electromagnetic compatibility (EMC) - Part 6-2. Generic Standards - Immunity for industrial environments.

The technical documentation file is constituted by

**VEHICLE SERVICE GROUP UK LTD**  
**3 Fourth Avenue**  
**Bluebridge Industrial Estate**  
**Halstead**  
**Essex C09 2SY**  
**United Kingdom**

S.G.di Ostellato, / /

**SIMONE FERRARI**  
**VP VSG Europe Managing Director**

UK7503-DC001P 01/07/2023

The version of this declaration conforms to the standard BS EN ISO/IEC 17050- 1:2010